

Notes on Full Scale Computational Fluid Dynamics Simulation for LHO End Y Wind Fence

Elyssa Hofgard
1/4/19
LIGO-T1900006

Background.

Ansys Fluent Computational Fluid Dynamics (CFD) modeling can be used to simulate the effect of the proposed porous fence on wind flow around End Station Y at LHO. The effects of both a curved and a straight fence were explored. The building was drawn in Solidworks and imported into Ansys Fluent.

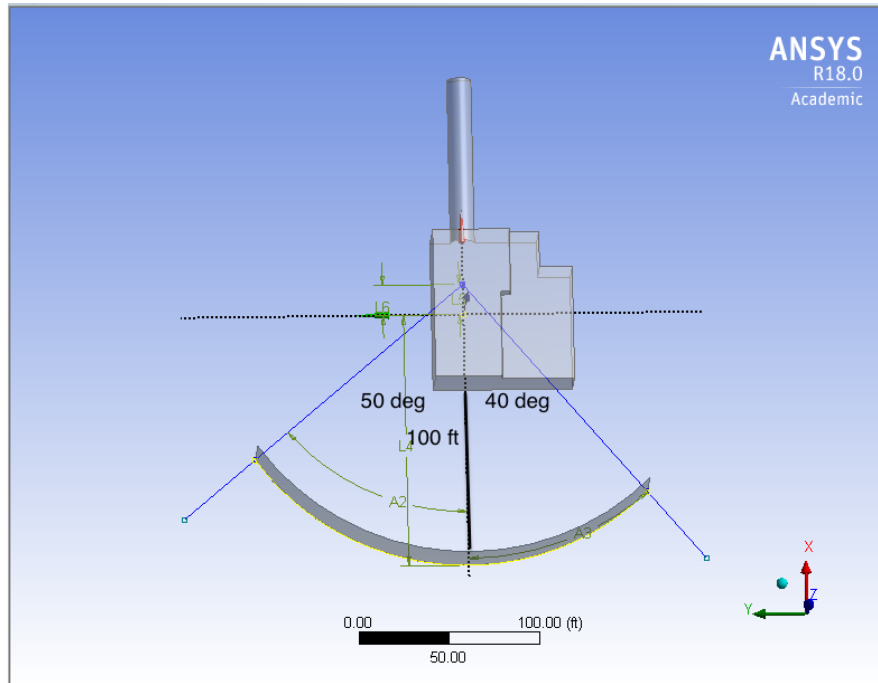

Figure 1. Curved fence computational fluid domain.

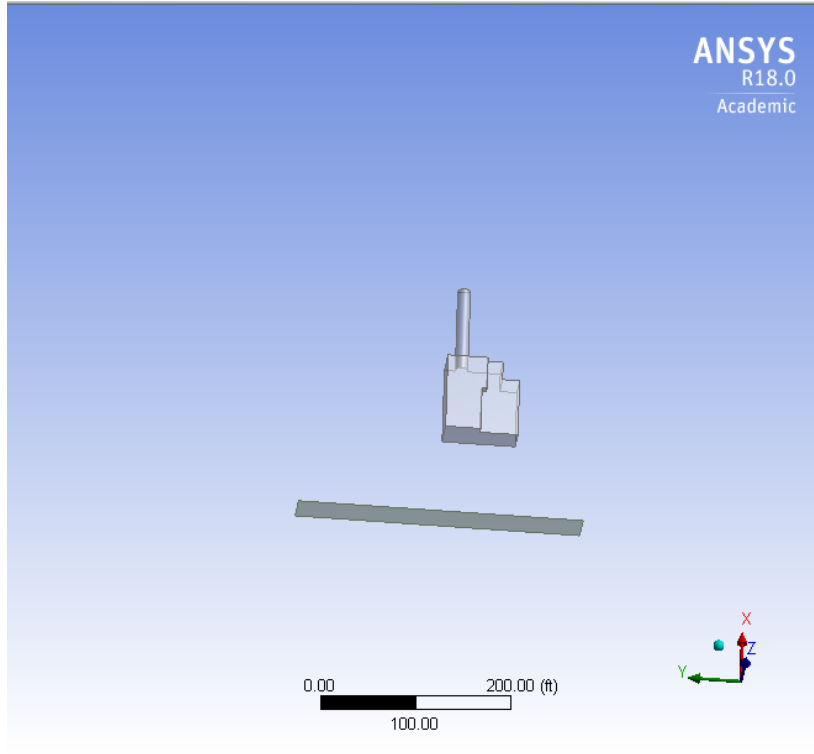

Figure 2. Straight fence computational fluid domain.

The building is to scale in both cases. The curved fence is centered on a line that passes through the center of the beam tube with a 142 ft radius. The center of the fence is located 100 ft from the building, for 250 ft of fencing. The dimensions are shown above. The straight fence is also centered on this line, and it is located 100 ft from the building, for 300 ft of fencing. Each fence begins at 4 ft from the ground and ends at 40 ft from the ground, for a 36 ft high fence. As End Y does not have the 12 ft cut in the ground that End X has, this corresponds to the same amount of coverage as End X. The enclosed flow domain is not shown, but it is 300 ft high, based on recommendations to make the fluid domain as large as feasibly possible.

At the atmospheric boundary layer, it is more accurate to specify a logarithmic wind velocity input that depends on height rather than a constant velocity input. This logarithmic velocity input is defined in fluid dynamics literature as $v = \frac{u^*}{K} \ln \frac{z+z_0}{z}$, where u^* and K are constants and z_0 is the roughness height of the bottom wall. For our model, we specified the roughness height to be 0.03 to correspond to the vegetation at LHO. We used a RNG k epsilon model to characterize the turbulent flow associated with the atmospheric boundary layer and the turbulent flow associated around bluff bodies such as End Station X. k epsilon models are the most widely used and validated turbulence models. They include two extra transport equations to represent the turbulence of the flow. The first transported variable is turbulent kinetic energy, k . The second

transported variable in this case is the turbulent dissipation, ϵ . ϵ determines the scale of the turbulence, whereas the first variable, k , determines the energy in the turbulence.

For our model, we specified a constant k input and a logarithmic epsilon input that also depends on height. I defined the bottom of the flow domain to be the higher part of the ground around End X. At the top of the flow domain, I calculated the proper velocity and epsilon conditions given the height of 300 ft. Each simulation converged after about 200 trials, with a minimum mesh size of .005 m. End Y simulations converged much faster than End X, illustrating that the cut in the ground model for End X could perhaps be improved. The mesh size could also perhaps be reduced given the relatively fast computation time.

The porous fence is modeled as a pressure jump with a finite thickness over which the pressure change follows the equation:

$$\Delta p = - \left(\frac{\mu}{\alpha} + C_2 \frac{1}{2} \rho v^2 \right) \Delta m$$

For turbulent flow, the first term (viscous loss) in this equation can be ignored. We set our boundary conditions to be face permeability (α) = $1e+20$ m, porous medium thickness (Δm) = 0.01 m, and $C_2 = 400$ 1/m for a 50% porous fence.

Results.

The wind at End Y also blows at an angle of 15 degrees, so I completed six simulations. For the first three, the wind is normal to the fence and End Y. I simulated a straight fence, a curved fence, and no fence. For the next three, I rotated the fence and End Y -15 degrees to simulate the wind blowing at 15 degrees to the fence and End Y. I again ran simulations with a straight fence, a curved fence, and no fence.

Wind Normal to the Fence.

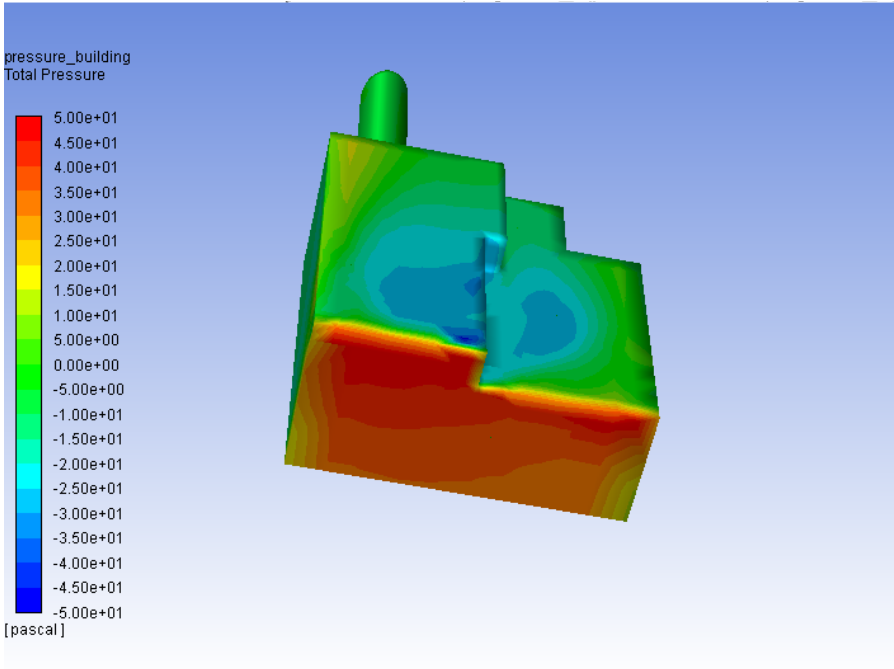

Figure 3. Pressure on End Y without fence, wind normal to building.

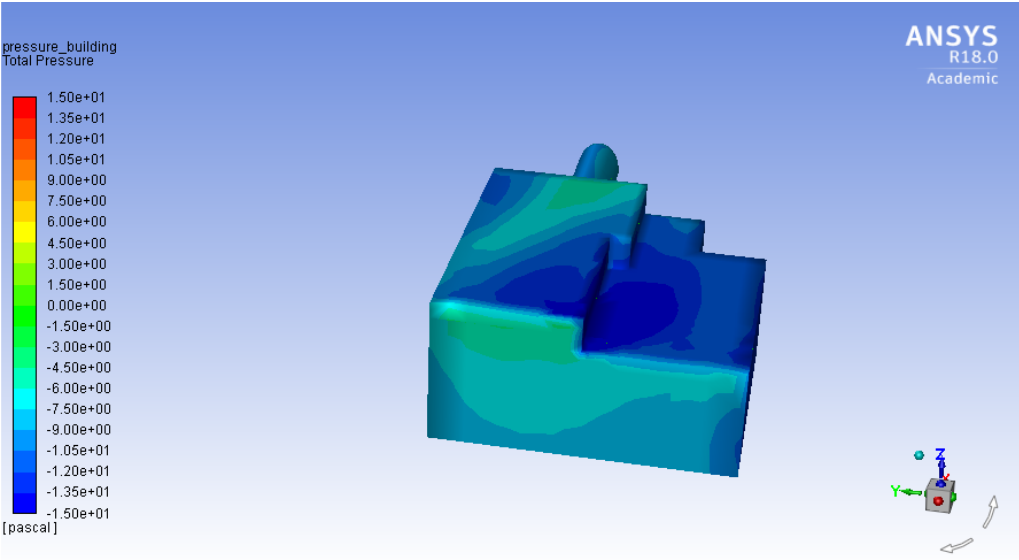

Figure 4. Pressure on End Y straight fence, wind normal to building.

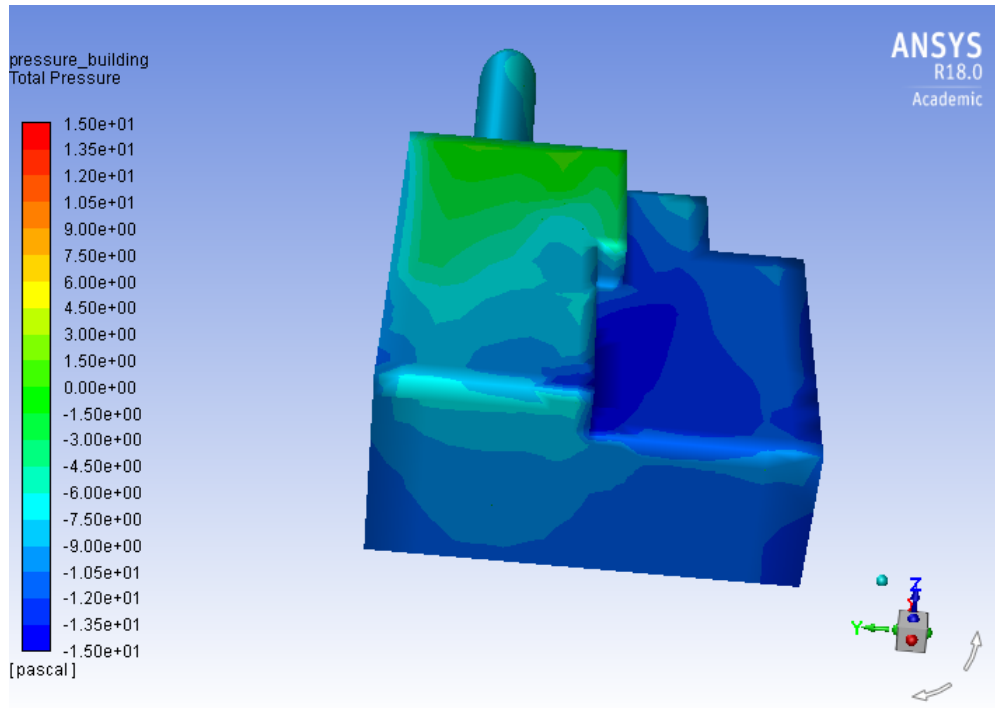

Figure 5. Pressure on End Y curved fence, wind normal to the building.

The effect of both fences on the pressure on the front and top of the building is immediately obvious. However, the curved fence appears to create lower pressure (more negative) on the front of the building, while creating zero pressure on the top of the building. The straight fence creates less of a negative pressure center on the front of the building, but it does not reduce the pressure to as large of an extent on the top of the building.

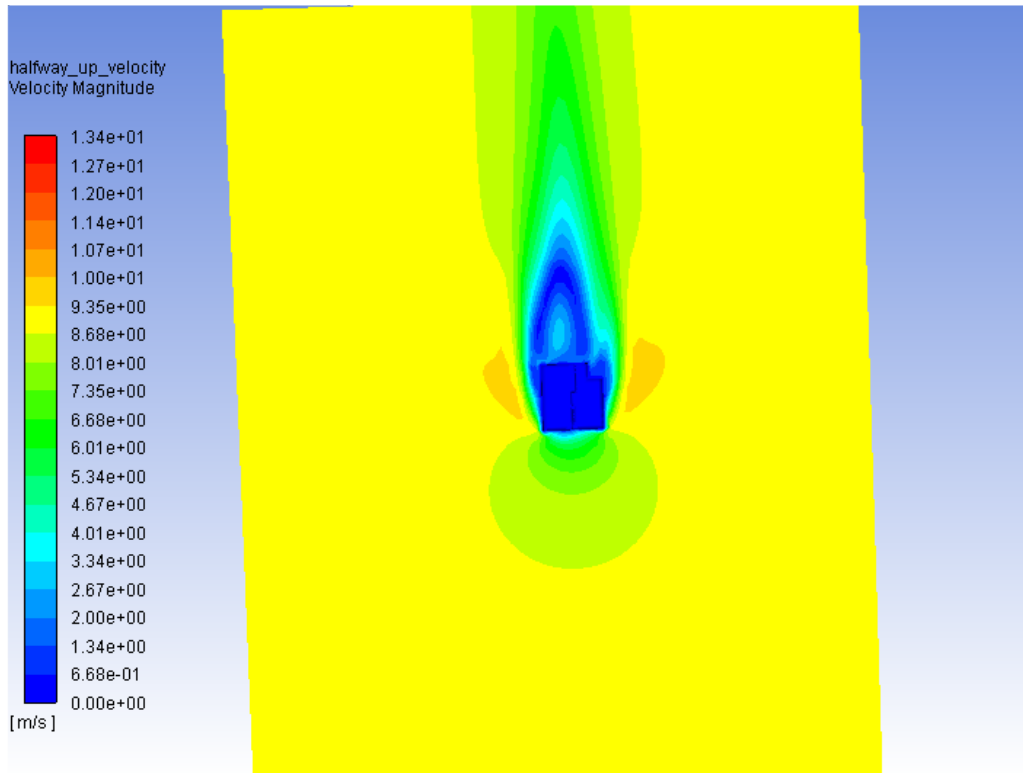

Figure 6. Wind velocity at a plane halfway up the building, no fence.

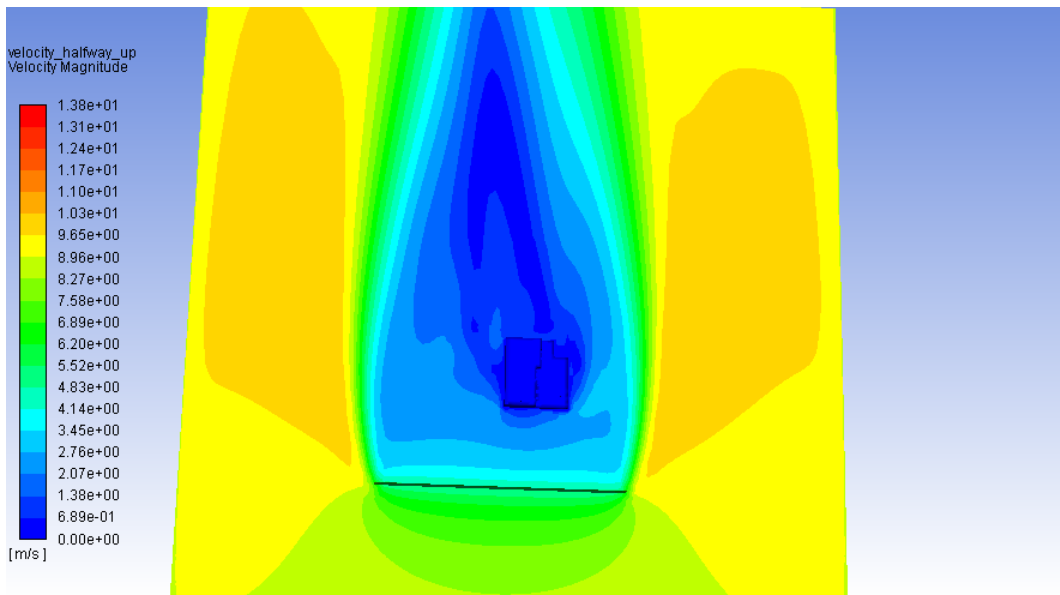

Figure 7. Velocity at a plane halfway up the building, straight fence.

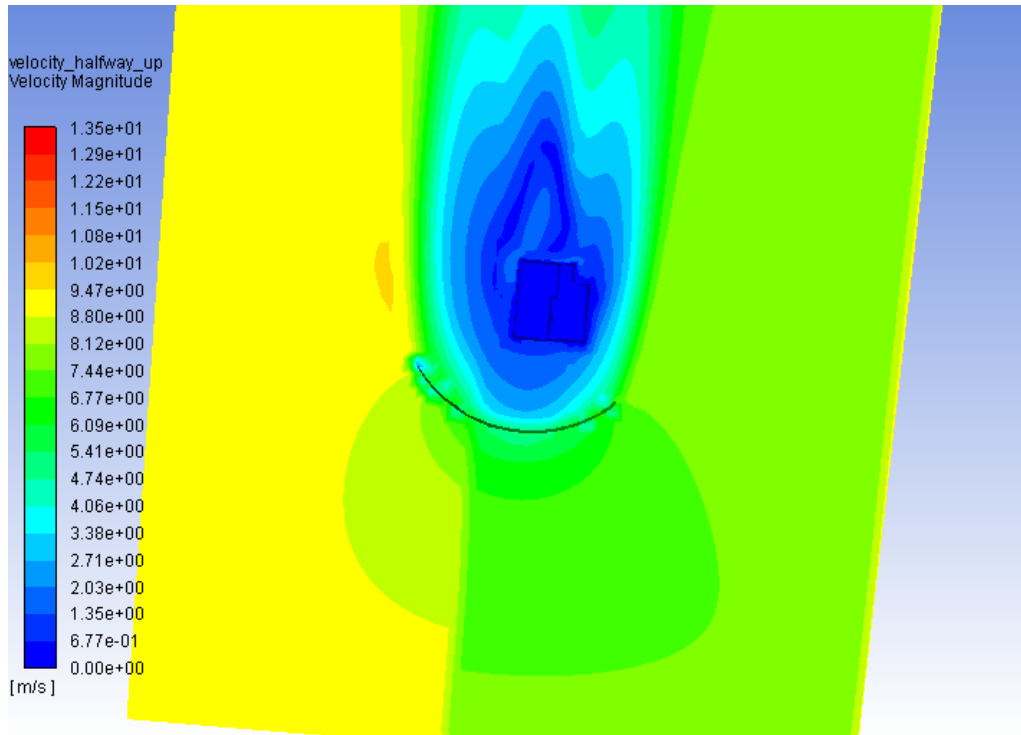

Figure 8. Velocity at a plane halfway up the building, curved fence.

Both fences appear to have a comparable effect in reducing the wind velocity at the front of the building. It is interesting how the different fence shapes have large effects on flow patterns both in front and to the side of the fences.

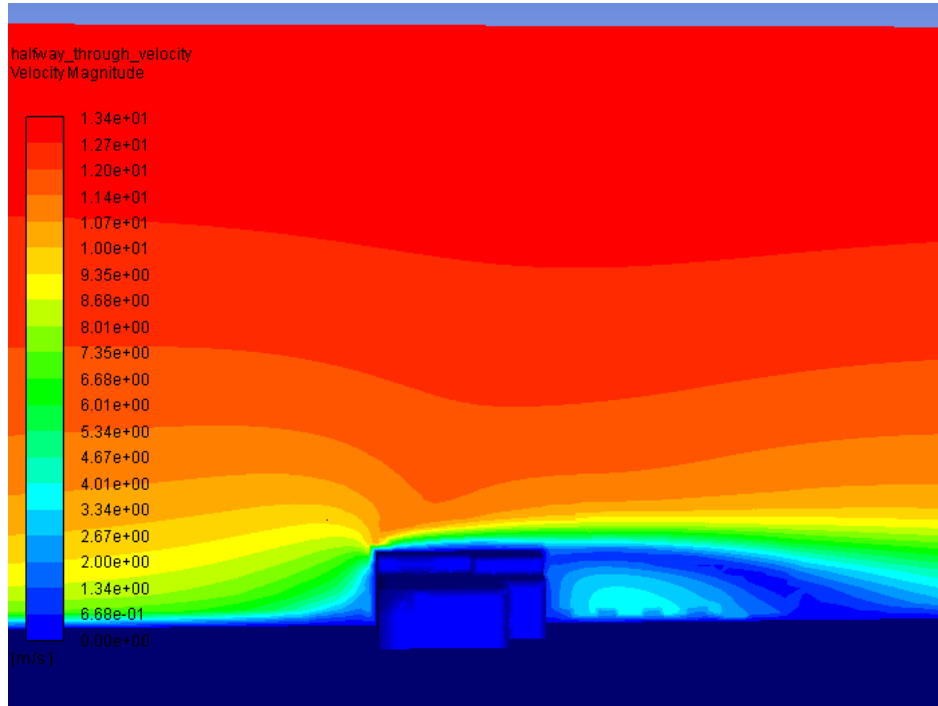

Figure 9. Velocity at a plane halfway through the building, no fence.

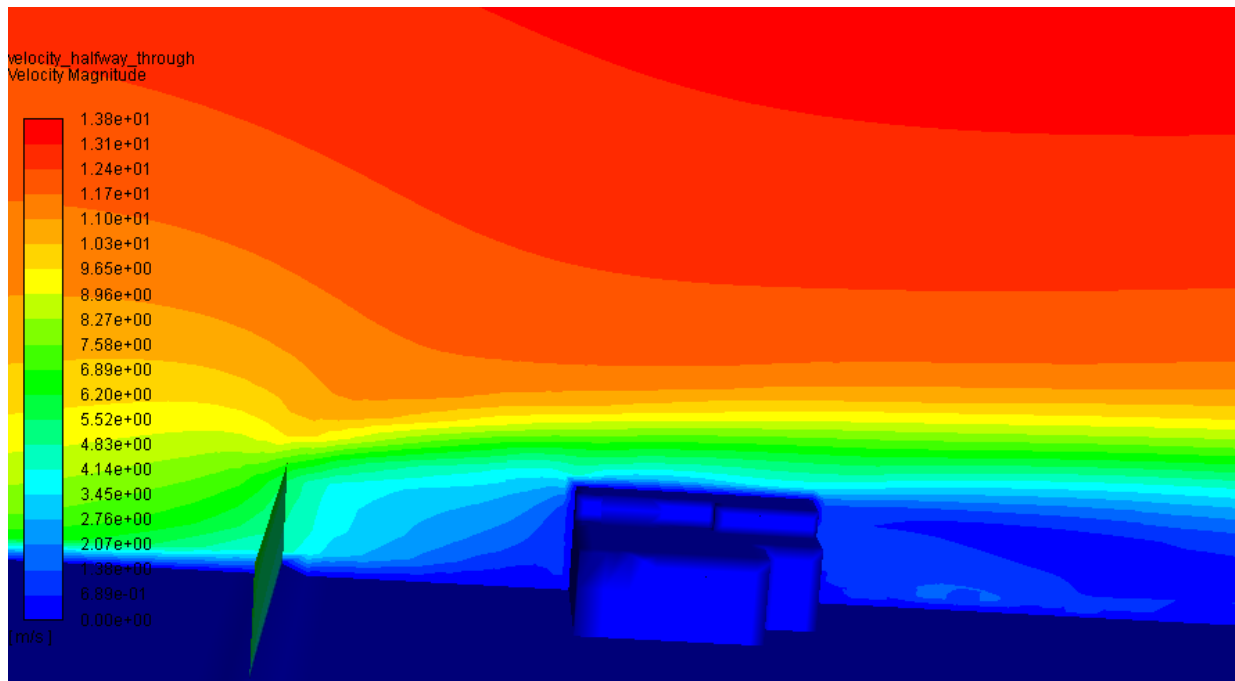

Figure 10. Velocity at a plane halfway through the building, straight fence.

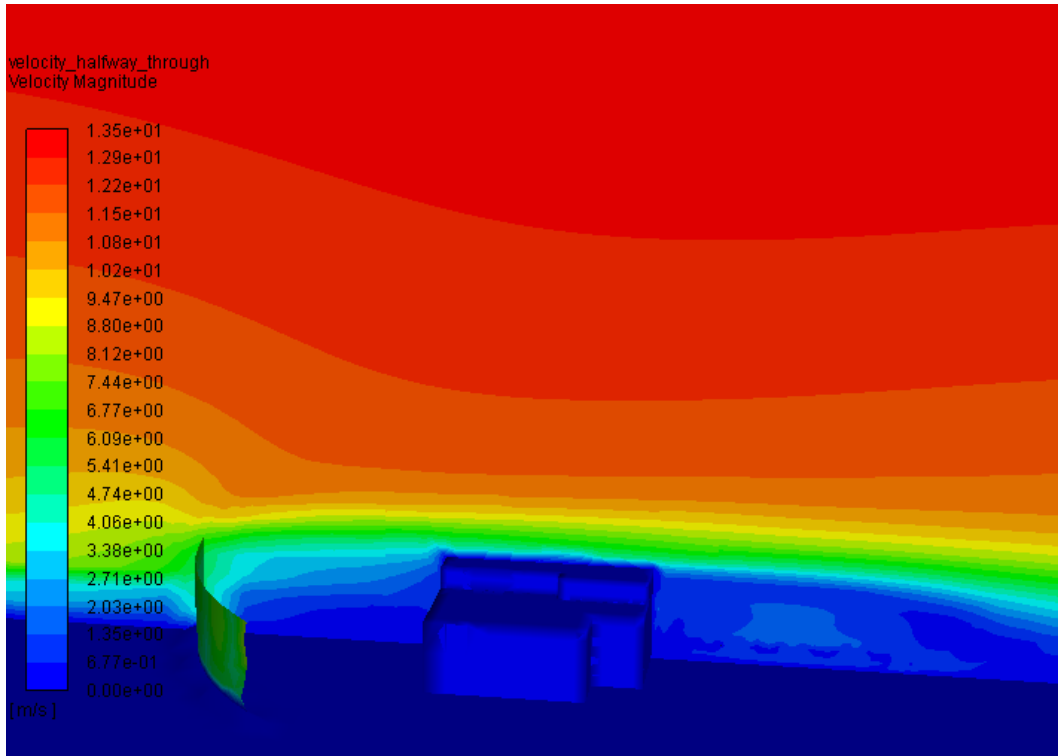

Figure 11. Velocity at a plane halfway through the building, curved fence.

The area of zero wind velocity (the darkest blue) behind the fence appears to be slightly larger with the curved fence than with the straight fence. In addition, the curved fence appears to reduce wind velocity more in front of the fence than the straight fence.

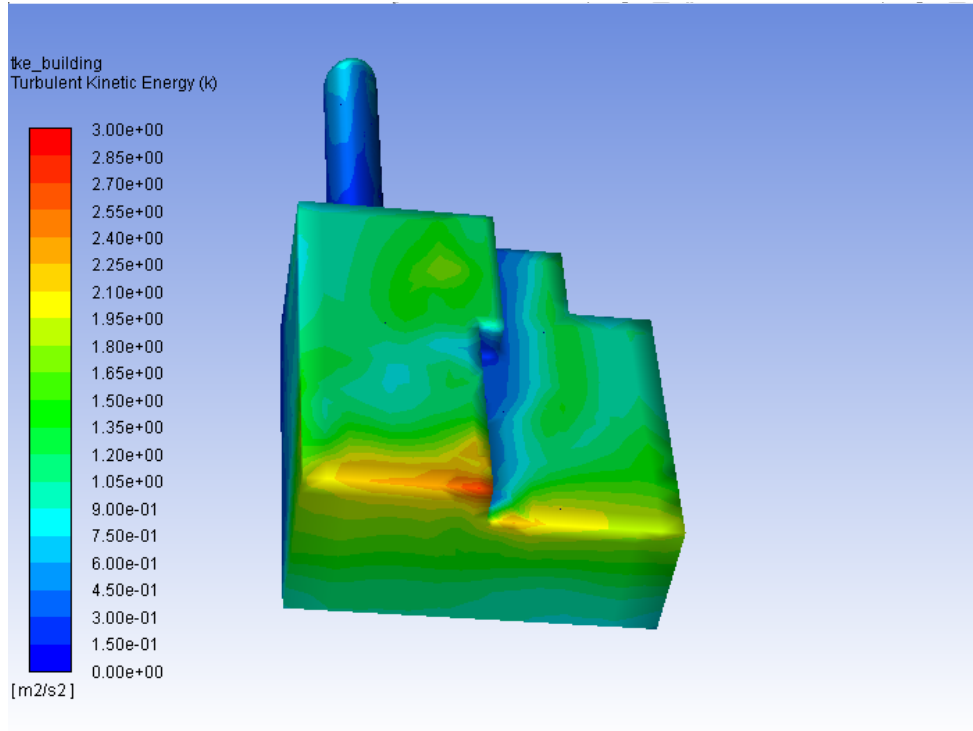

Figure 12. Turbulent kinetic energy (tke) on the building, no fence.

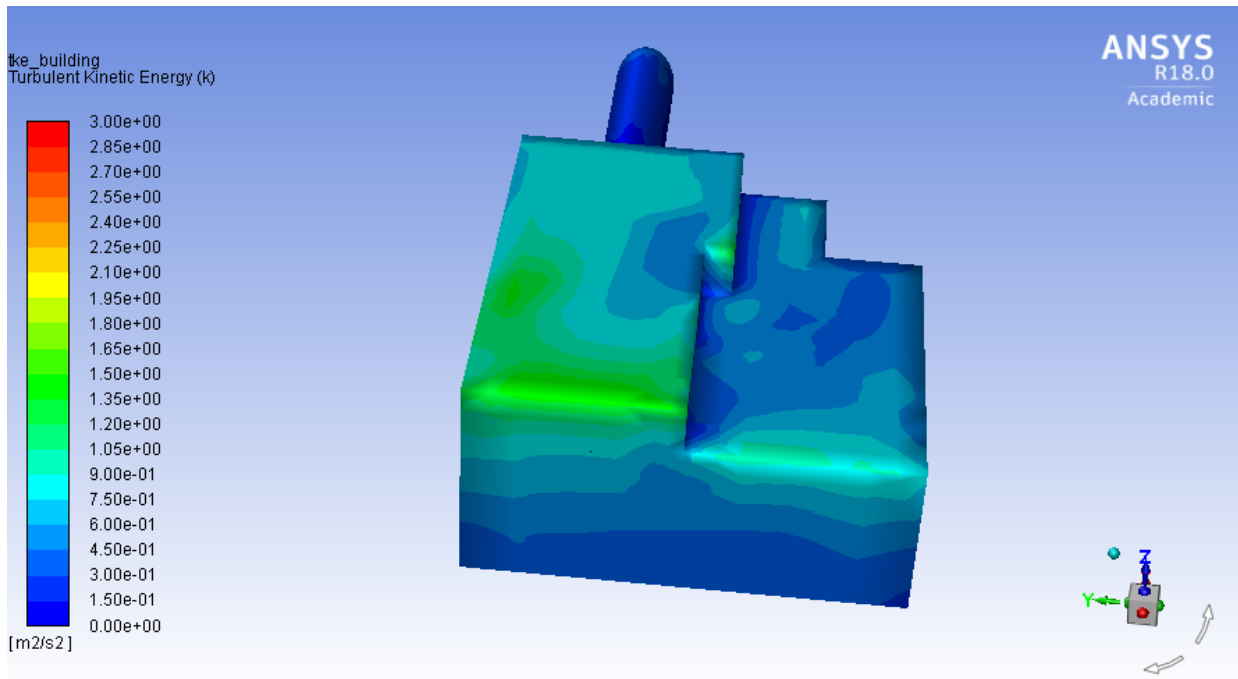

Figure 13. Turbulent kinetic energy on the building, straight fence.

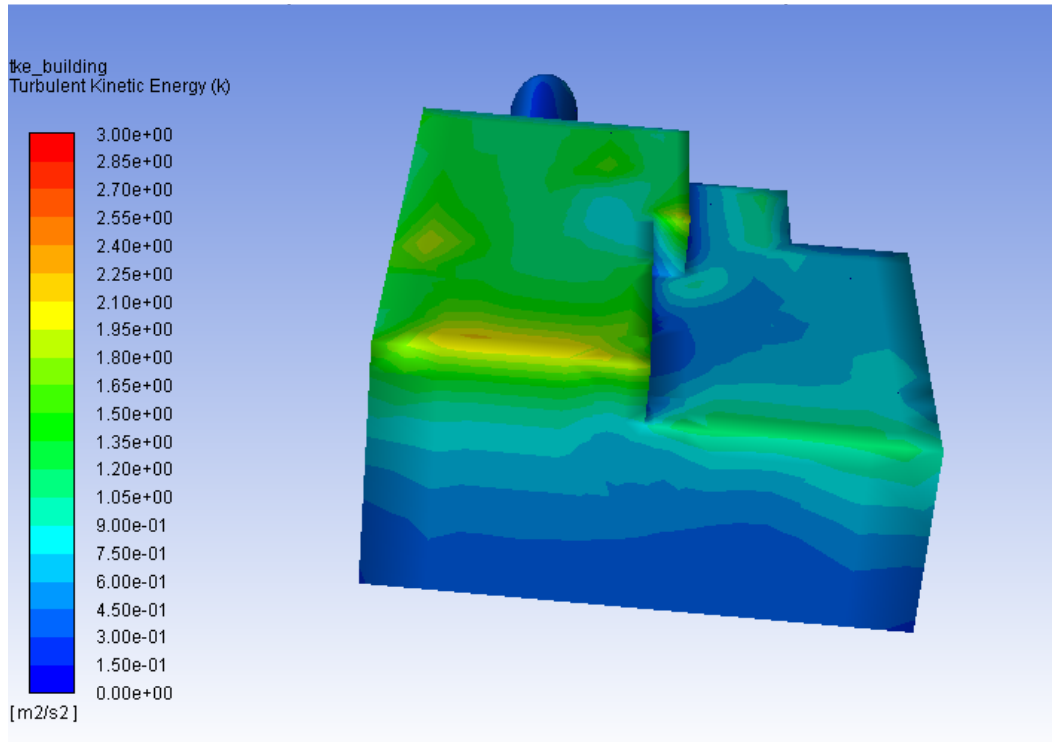

Figure 14. Turbulent kinetic energy on the building, curved fence.

Turbulent kinetic energy is the mean energy per unit mass associated with eddies in turbulent flow. It is associated with the rms velocity of the flow. As higher turbulence is associated with eddies, we would ideally want to fence to reduce or keep the turbulence constant. It appears that both fences effectively reduce turbulence at the front of the building. However, the straight fence appears to reduce turbulence more effectively on top of the building. This effect should be explored further through considering vector plots of the solution.

Wind at a 15 Degree Angle.

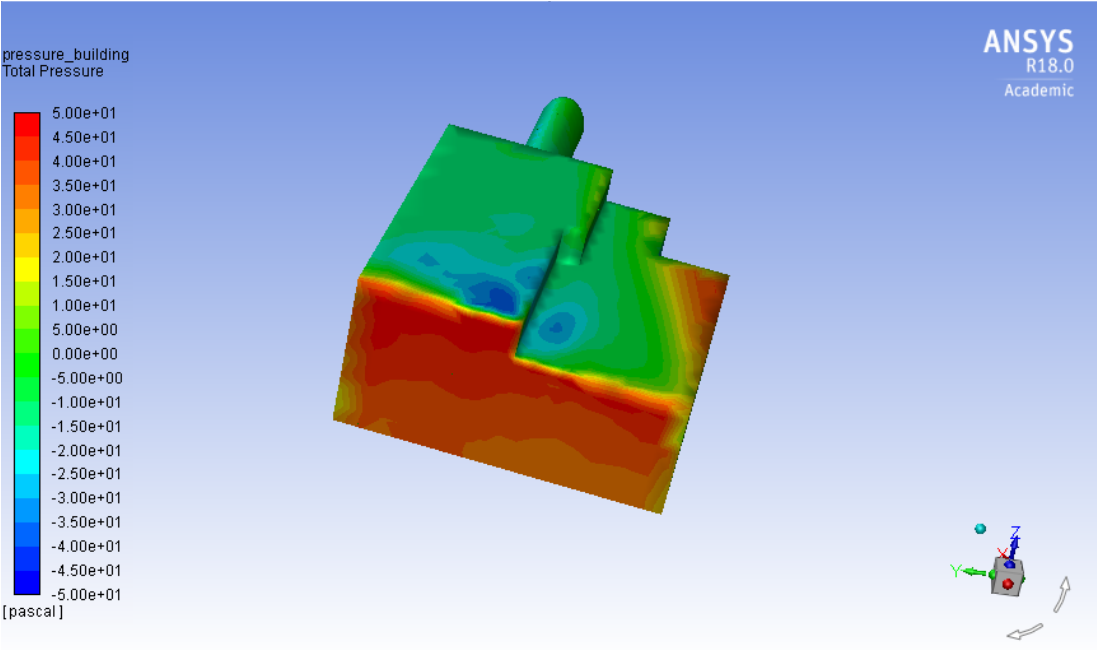

Figure 15. Pressure on the building, no fence.

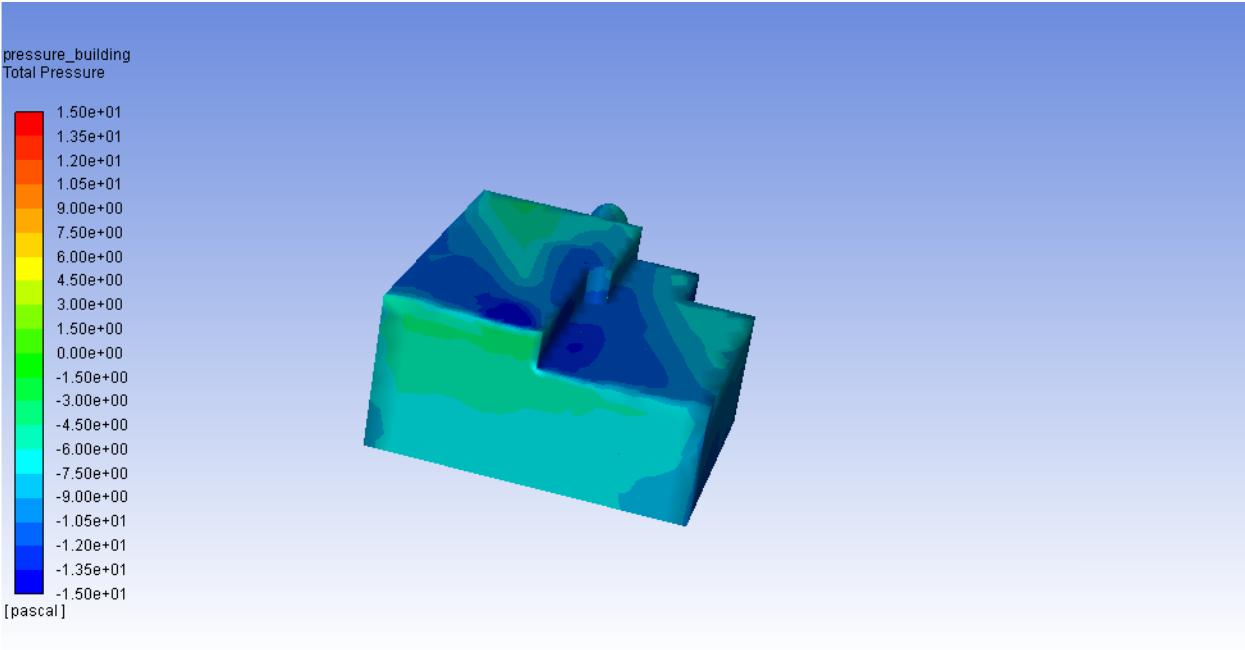

Figure 16. Pressure on the building, straight fence.

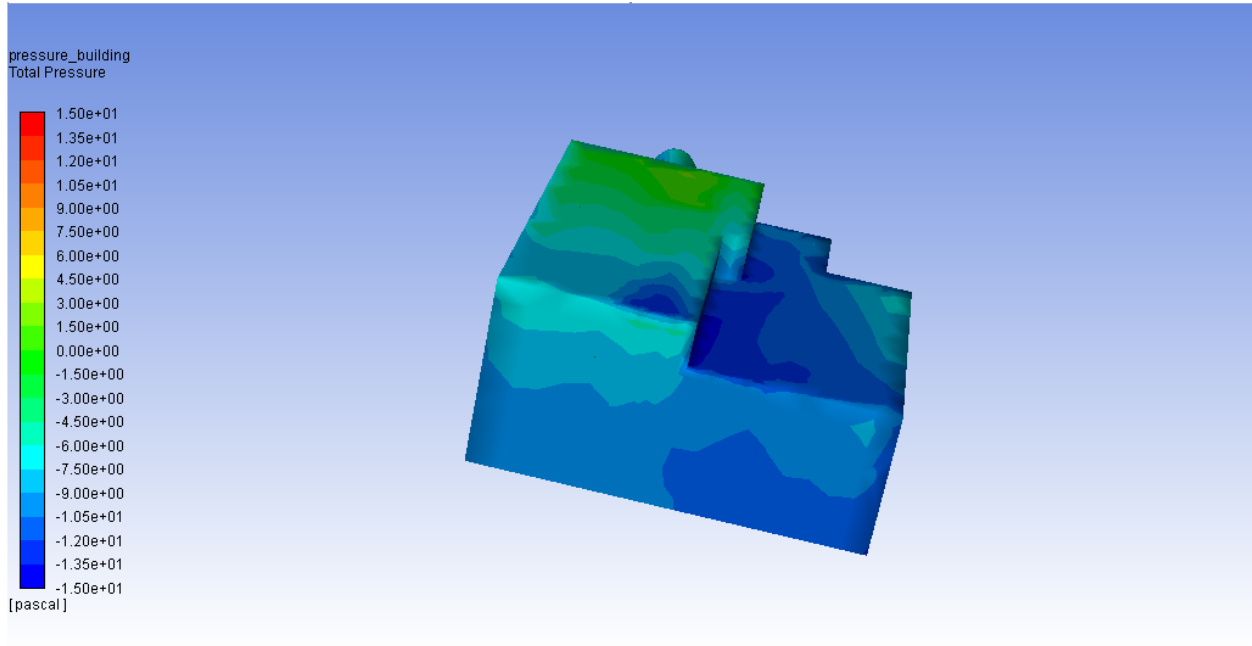

Figure 17. Pressure on the building, curved fence.

While the pressure contours are different due to the effect of the angled wind flow, the pressure again appears to be more negative on the front of the building with the curved fence. In the load calculations (shown below), this does not seem to have a large effect.

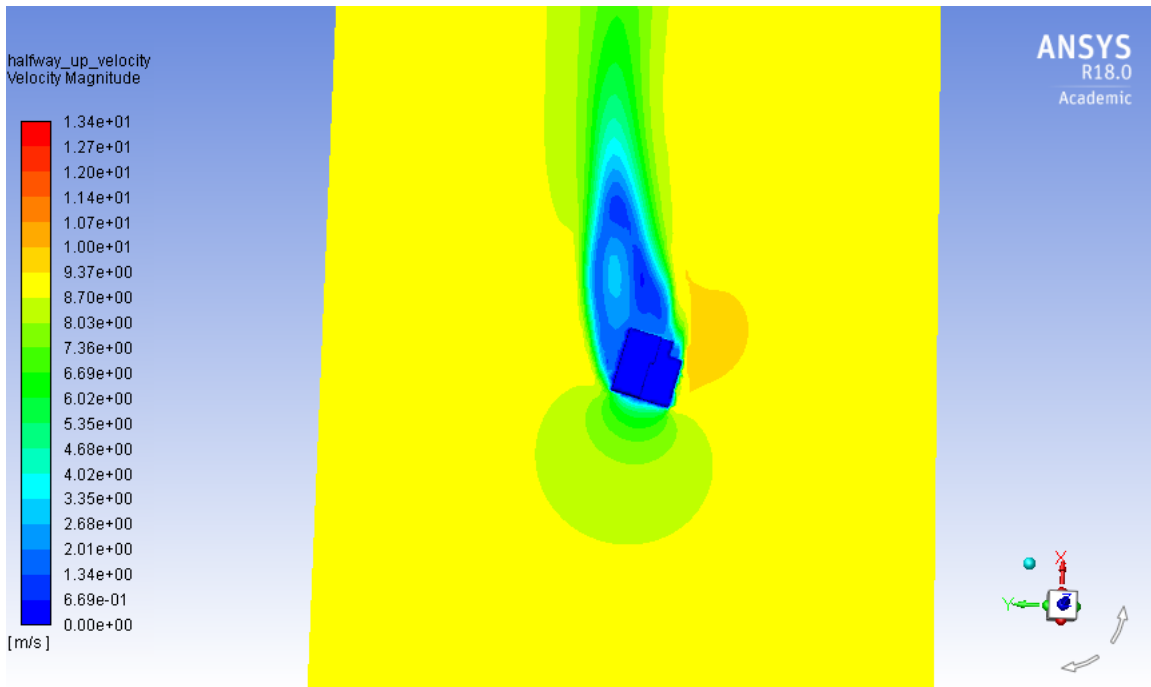

Figure 18. Wind velocity at a plane halfway up the building, no fence.

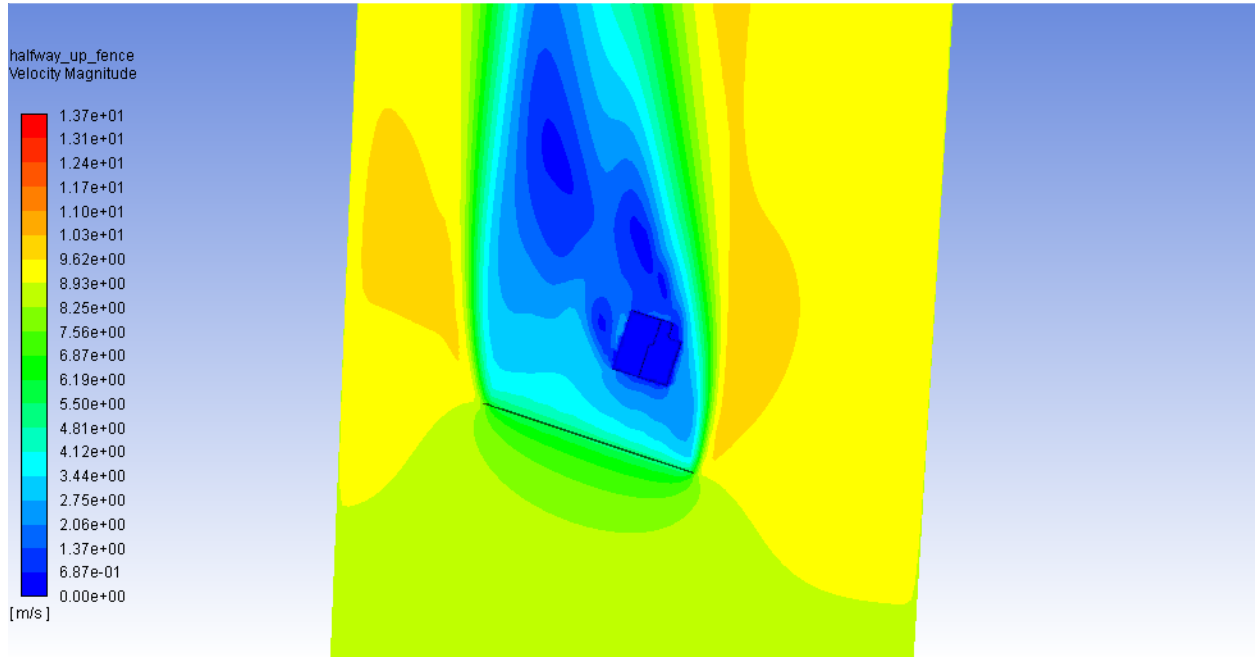

Figure 19. Wind velocity at a plane halfway up the building, straight fence.

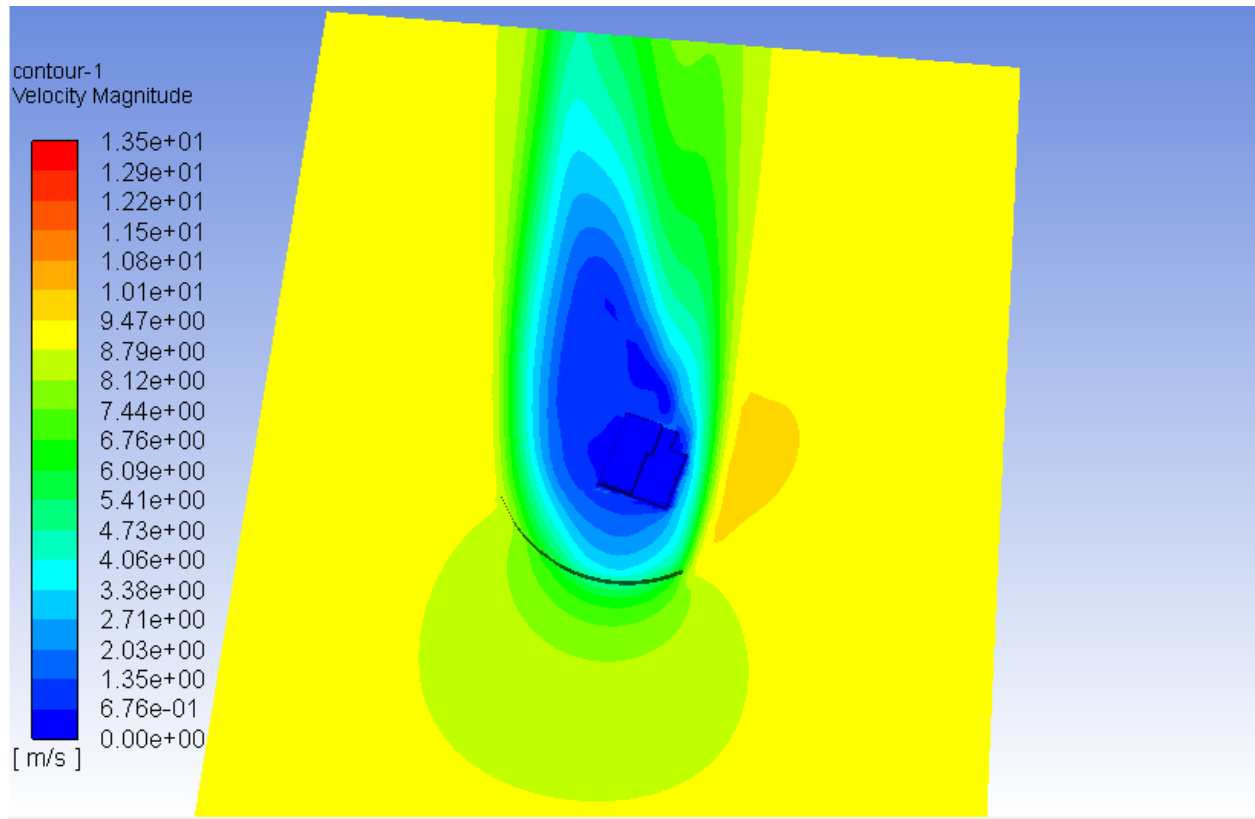

Figure 20. Wind velocity at a plane halfway up the building, curved fence.

With a 15 degree angle, the straight fence has a larger “wake” or region where the wind velocity is much slower than the curved fence. However, the “wake” or blue region behind the curved fence appears to be more uniform than the straight fence. This corresponding uniformity could serve to lessen turbulent eddies.

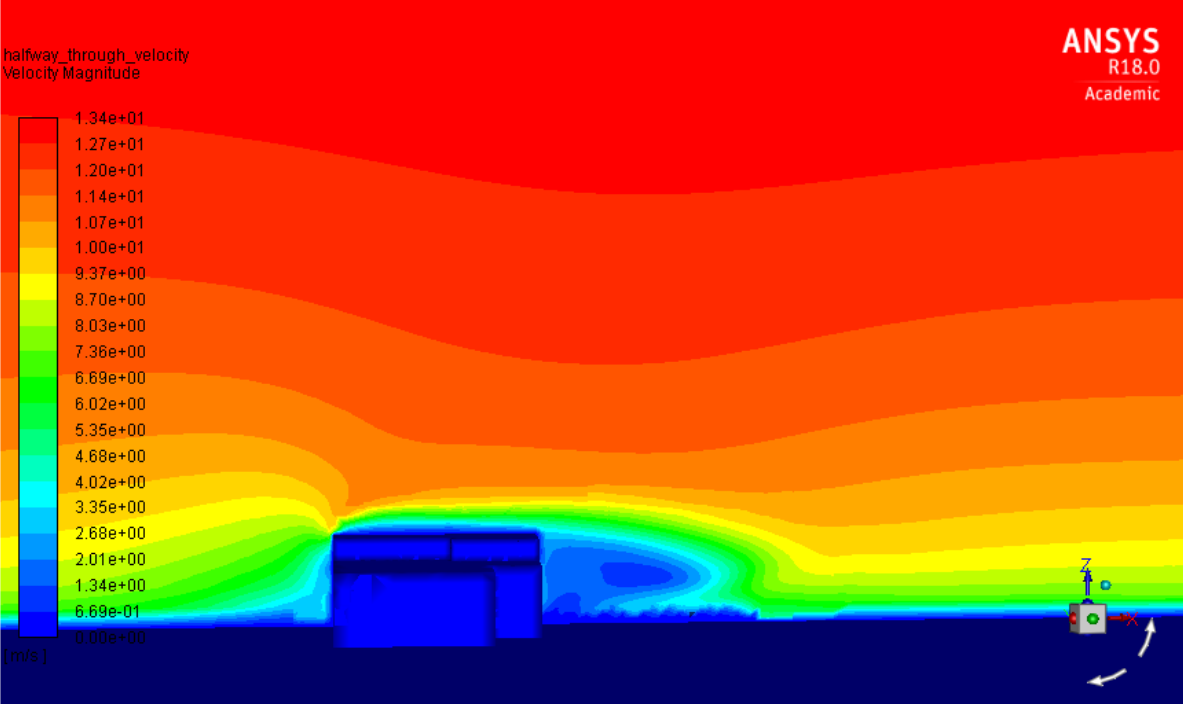

Figure 21. Velocity at a plane halfway through the building, no fence.

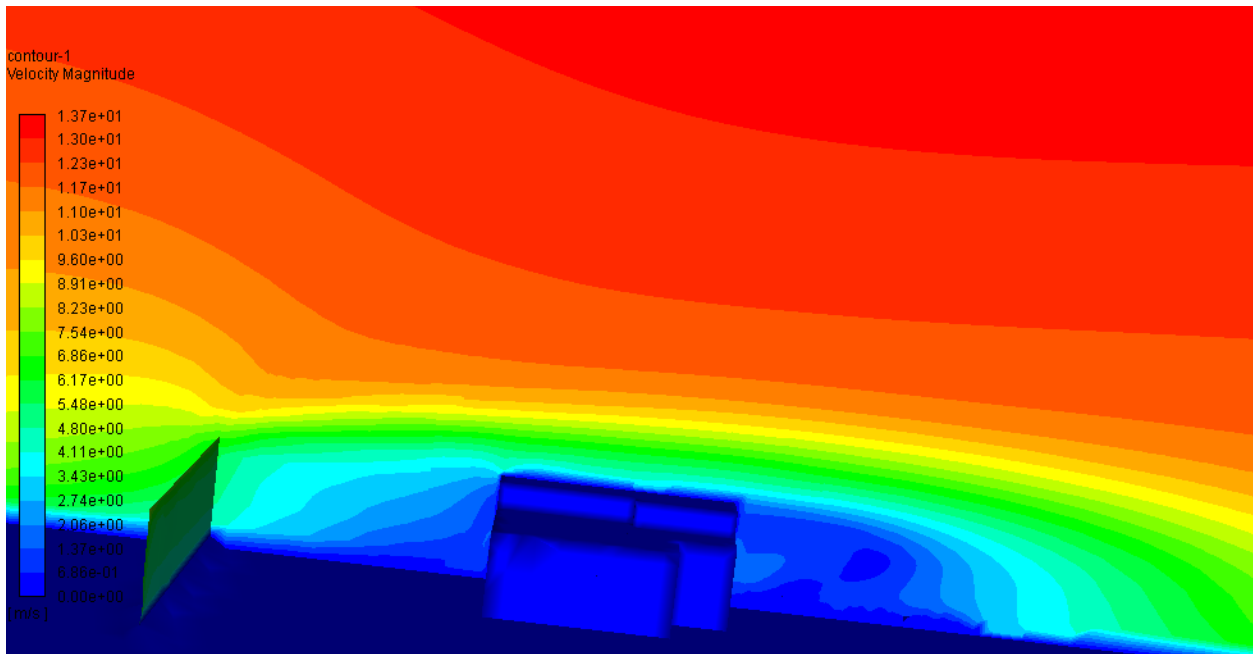

Figure 22. Velocity at a plane halfway through the building, straight fence.

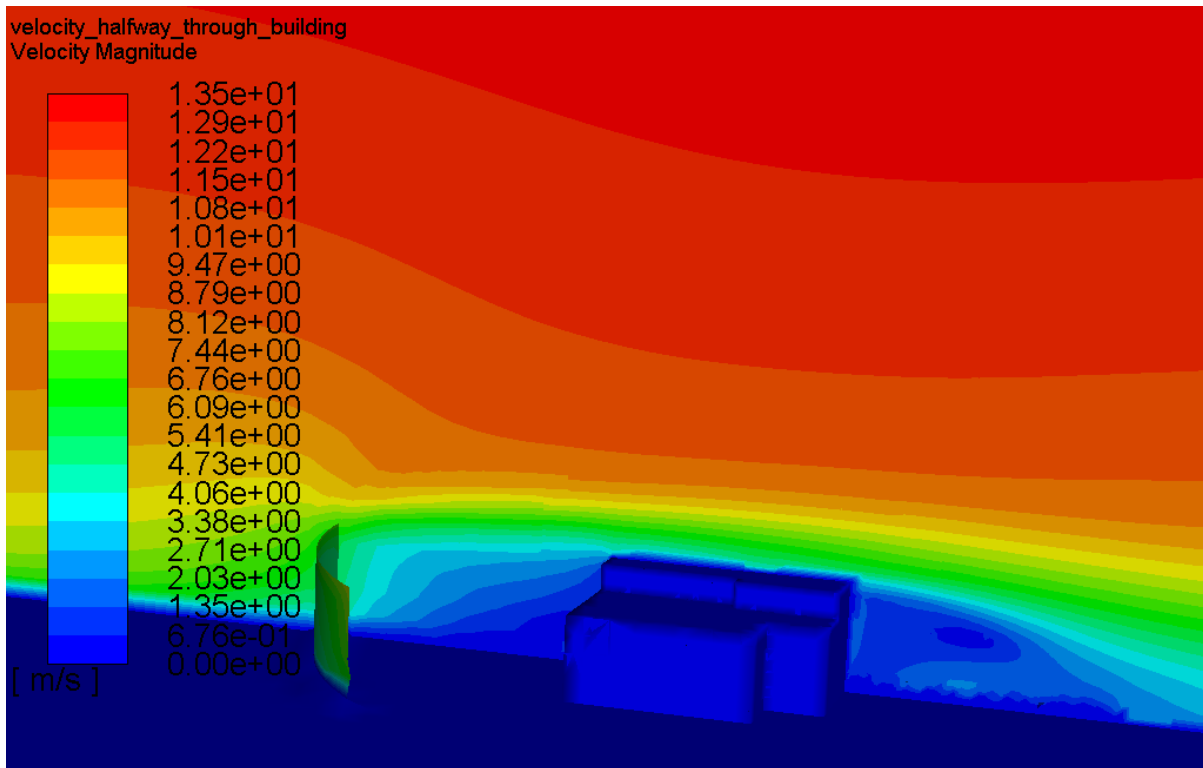

Figure 23. Velocity at a plane halfway through the building, curved fence.

Velocity and Load Comparisons for Fences.

Wind Normal to the Fence.

Without the fence, the total load on the building was 17361 N. With the curved fence, the load was 8733 N (50% reduction). With the straight fence, it was 8950 N (48% reduction). Without the fence, the average velocity on the front, or the side of the building facing the wind, was 6.14 m/s. With the curved fence, this velocity was 1.56 m/s (75% reduction). With the straight fence, it was 2.14 m/s (65% reduction).

Wind at 15 degrees to the Normal.

Without the fence, the total load on the building was 18074 N. With the curved fence, the load was 8843 N (51% reduction). With the straight fence, it was 8604 N (52% reduction). Without the fence, the average velocity on the front of the building was 5.32 m/s. With the curved fence, this velocity was 1.71 m/s (68% reduction). With the straight fence, it was 1.99 m/s (63% reduction).

Conclusions.

These simulations demonstrate that both a curved and a straight 50% porous fence may be quite effective in reducing the force on End Y and the wind velocity at End Y. These fence types are comparably effective in reducing the wind load on the building. However, the curved fence appears to be slightly more effective in reducing wind speed at the building. The fence types are also comparably effective in a flow angled with respect to the building rather than normal to the building. However, this model should be further explored and verified. As the Stanford LIGO group is exploring the effect that the computational mesh has on simulation results, this could perhaps be rerun with a smaller mesh size. In addition, the load calculations should be verified. It would also be interesting to further analyze these model results with vector plots.