

- NOTES CONTINUED:**
- 5. SCRIBE, ENGRAVE (A VIBRATORY TOOL MAY BE USED), LASER MARK OR MECHANICALLY STAMP (NO INKS OR DYES) DRAWING PART NUMBER, REVISION (AND VARIANT OR 'TYPE' IF APPLICABLE) ON NOTED SURFACE OF PART FOLLOWED ON THE NEXT LINE WITH A THREE DIGIT SERIAL NUMBER. SERIAL NUMBERS START AT 001 FOR THE FIRST ARTICLE AND PROCEED CONSECUTIVELY. USE MINIMUM 0.12" HIGH CHARACTERS, UNLESS THE SIZE OF THE PART DICTATES SMALLER CHARACTERS. EXAMPLE: DXXXXXX-VY, TYPE-XX, S/N XXX
  - 6. MATERIAL: SCHOTT ATHERMAL® 14 A1 DIN GS 0196 CE WITHOUT GOLD MIRROR COATING.
  - 7. PART TO BE FREE OF SCRATCHES. NO ABRASION AT CUT EDGES.
  - 8. 40/20 SCRATCH/DIG (GOAL) BUT SCONSISTENT WITH COMMERCIAL-OFF-THE-SHELF WELDER'S GLASS MATERIAL.
  - 9. COAT 1 SIDE 'S1' (AS SHOWN ON DRAWING)
  - 10. R < 0.5% AT 1064 NM LASER WAVELENGTH.
  - 11. A.O.I= 0 DEG. (NORMAL INCIDENCE BEAM)
  - 10. CUT AWAY FROM SIDE 1 AS PER DETAIL 'A'
  - 11. CLEAR APERTURE 0.25" FROM EDGE ON ALL SIDES OF EACH PIECE OF GLASS (i.e. HOLDING AREA ON GLASS FOR COATING)

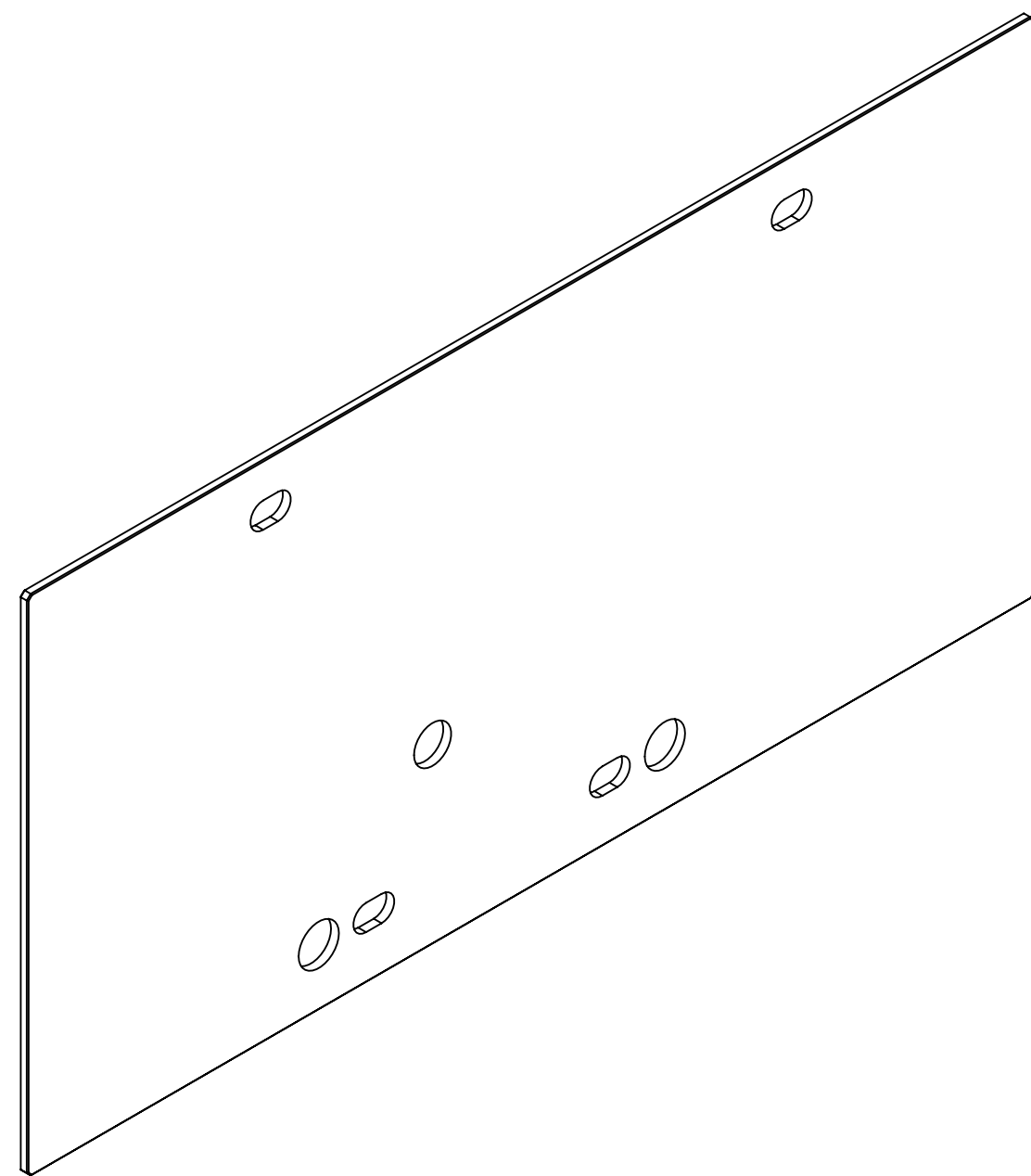

ISO VIEW

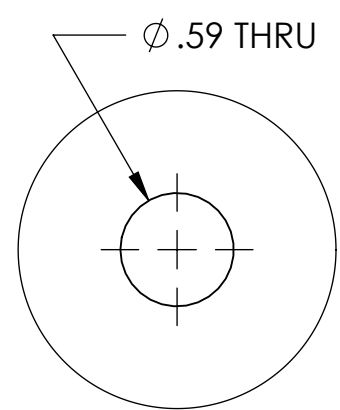

DETAIL C  
SCALE 1 : 1

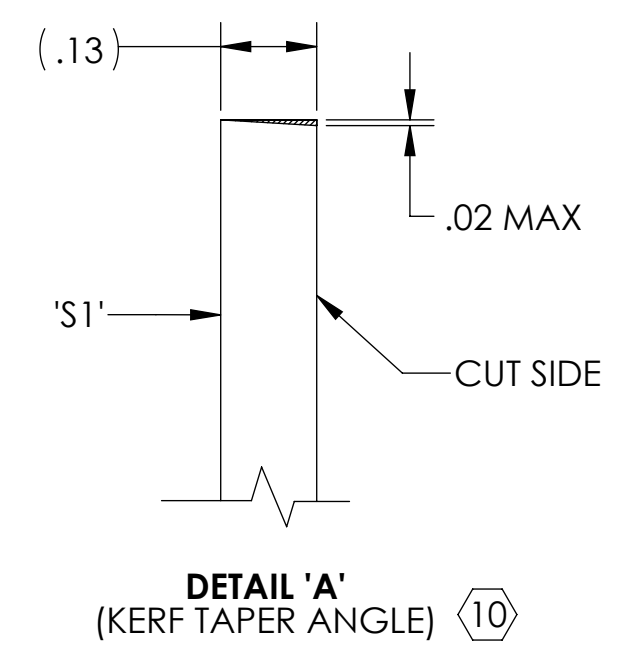
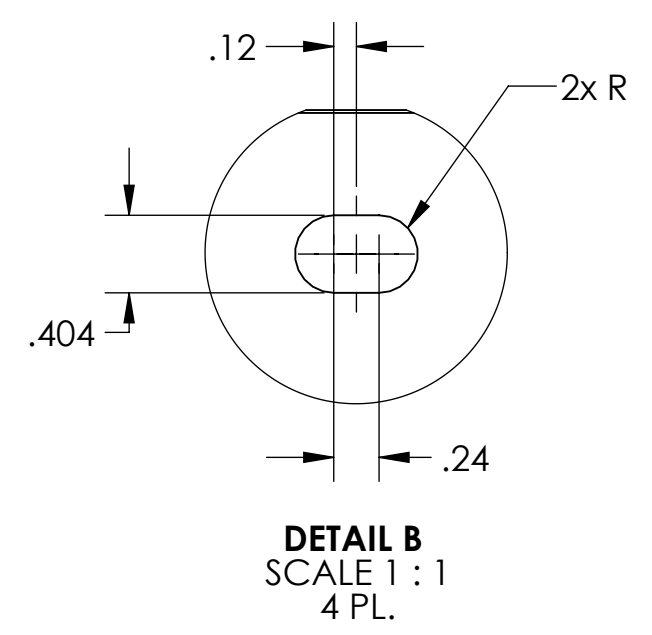
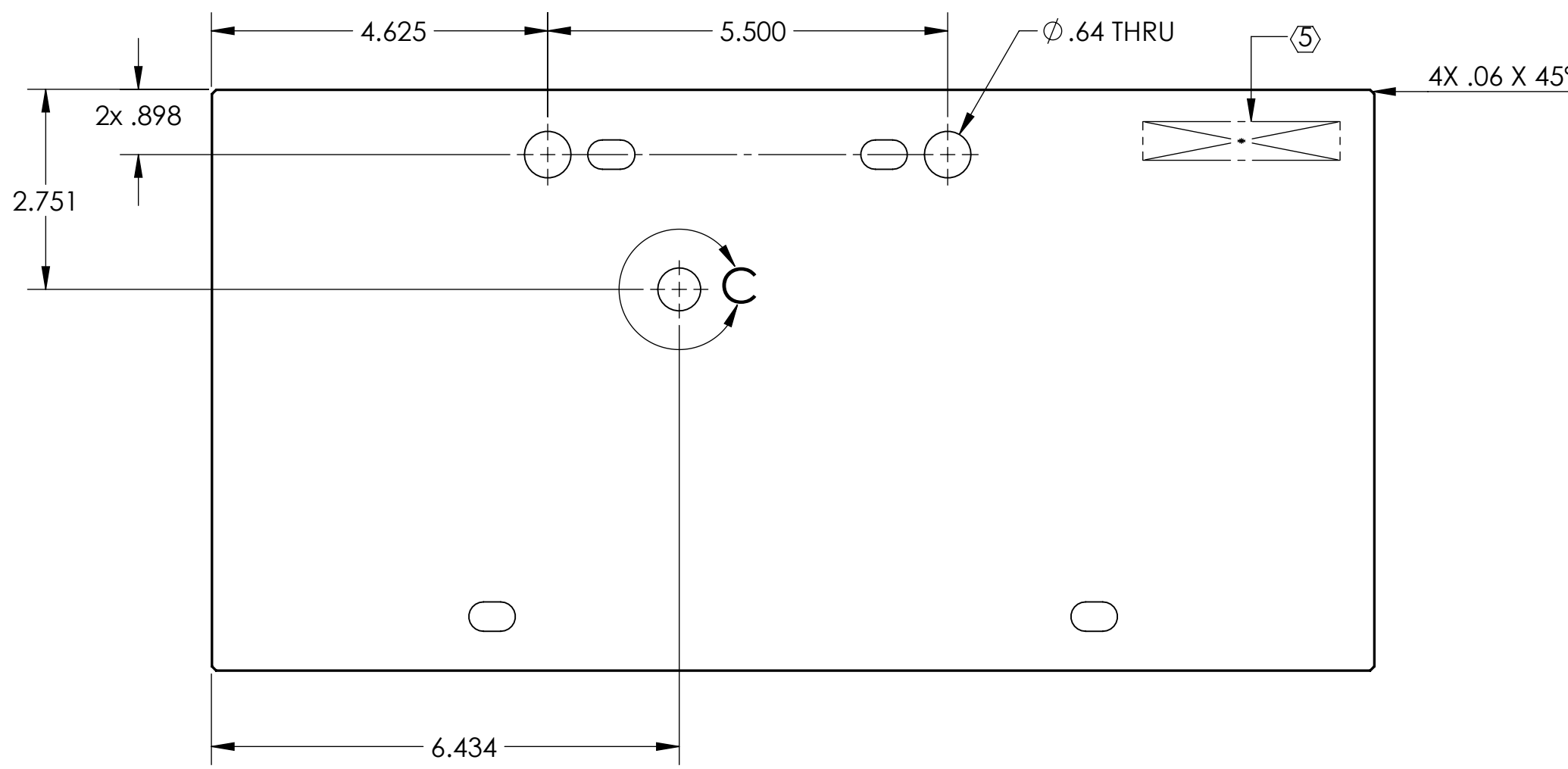
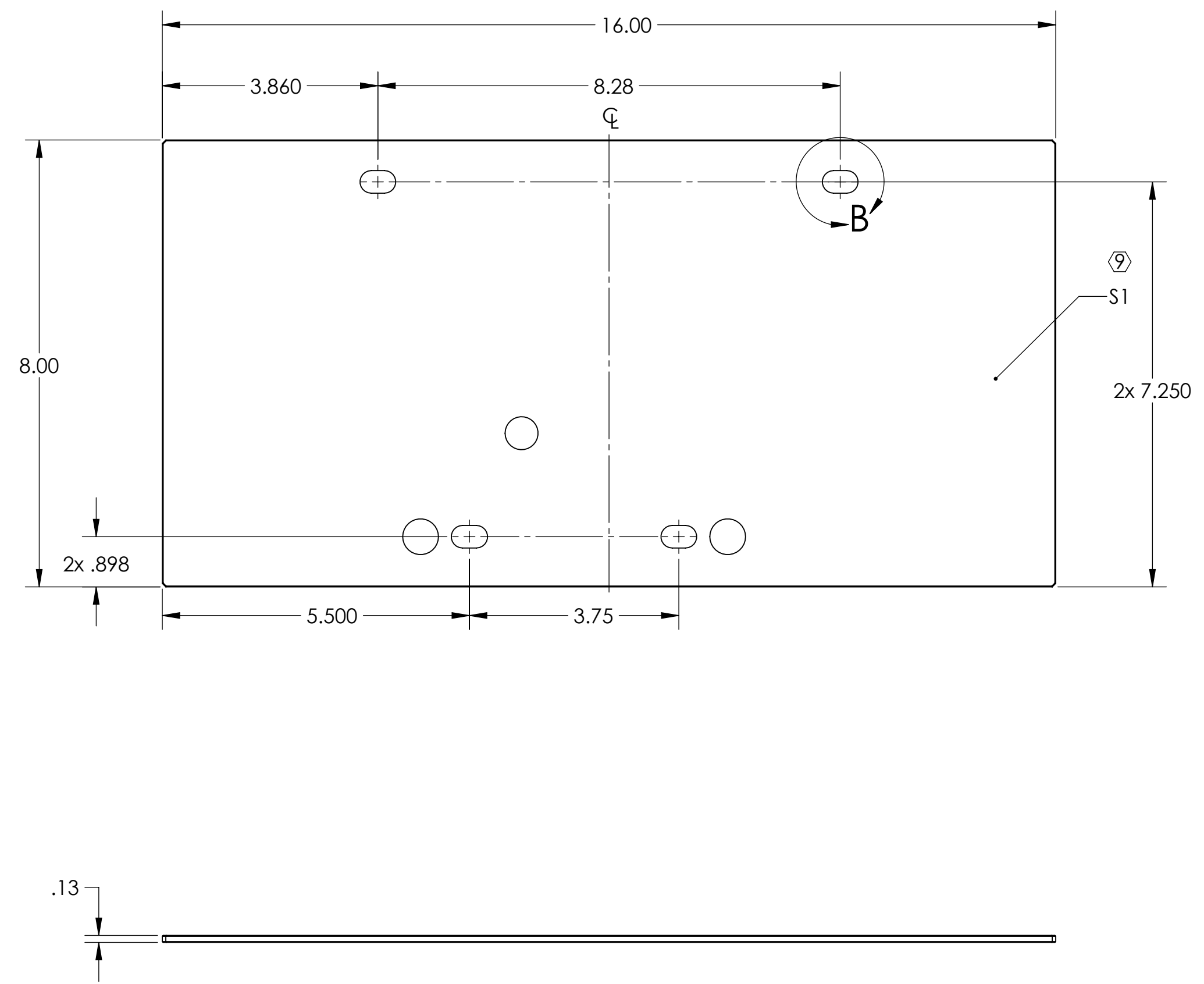

REV.	DATE	DCN #	DRAWING TREE #
v1	06 FEB 2015	E1500047-x0	-
-	-	-	-
-	-	-	-

DIMENSIONS ARE IN INCHES		TOLERANCES: .XX ± .01 .XXX ± .005		ANGULAR ± 1.0°	
MATERIAL		FINISH		NEXT ASSY	
SEE NOTE 6		N/A μinch		D0900295	

**LIGO** CALIFORNIA INSTITUTE OF TECHNOLOGY  
MASSACHUSETTS INSTITUTE OF TECHNOLOGY

SYSTEM: ADVANCED LIGO      SUB-SYSTEM: AOS

PART NAME aLIGO, OMC, Stray light baffle, Outer Panel (TRANS AIR)					
DESIGNER	E.SANCHEZ	22 JAN 2015	SIZE	DWG. NO.	REV.
DRAFTER	E.SANCHEZ	06 FEB 2015	D	D1500044	v1
CHECKER	SEE DCC	SEE DCC	SCALE: 1:2	PROJECTION:	SHEET 1 OF 1
APPROVAL	SEE DCC	SEE DCC			

D1500044 aLIGO, OMC, Stray light baffle, Outer Panel (TRANS AIR), PART PDM REV.: DRAWING PDM REV.: