

REV.	DATE	DCN #	DRAWING TREE #
v1	06 FEB 2015	E1500047-x0	-
v2	07 APR 2015	E1500163-x0	-
-	-	-	-

NOTES CONTINUED:
 ⑤ SCRIBE, ENGRAVE (A VIBRATORY TOOL MAY BE USED), LASER MARK OR MECHANICALLY STAMP (NO INKS OR DYES) DRAWING PART NUMBER, REVISION (AND VARIANT OR 'TYPE' IF APPLICABLE) ON NOTED SURFACE OF PART FOLLOWED ON THE NEXT LINE WITH A THREE DIGIT SERIAL NUMBER. SERIAL NUMBERS START AT 001 FOR THE FIRST ARTICLE AND PROCEED CONSECUTIVELY. USE MINIMUM 0.12" HIGH CHARACTERS, UNLESS THE SIZE OF THE PART DICTATES SMALLER CHARACTERS. EXAMPLE: DXXXXXX-VY, TYPE-XX, S/N XXX

⑥ COAT SIDE 'S1' AS INDICATED ON DRAWING. REFER TO LIGO E1500201 FOR AIR COATING SPECIFICATIONS.

⑦ CUT AWAY FROM SIDE 1 AS PER DETAIL 'A'.

-101
(RIGHT HAND)

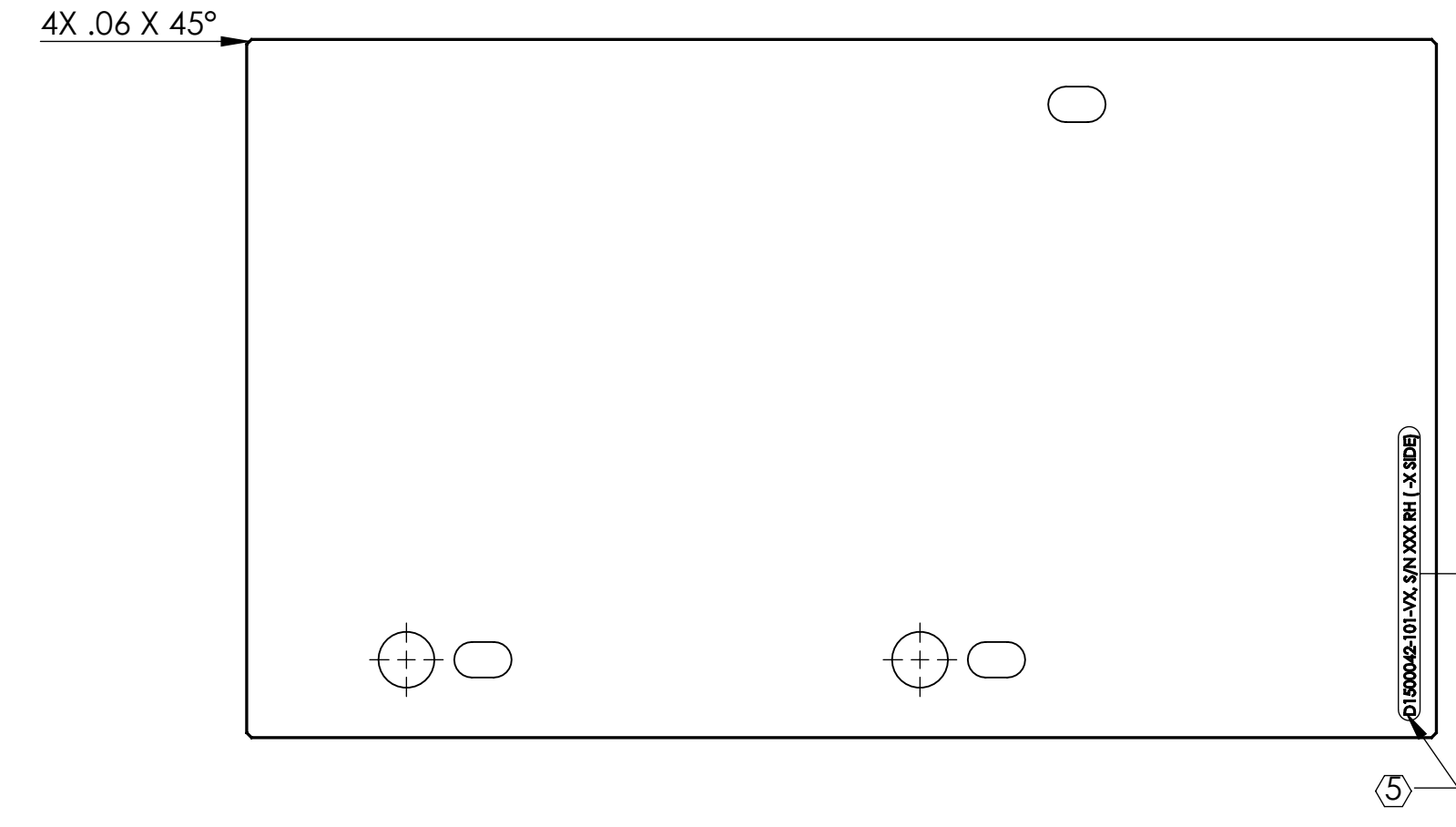
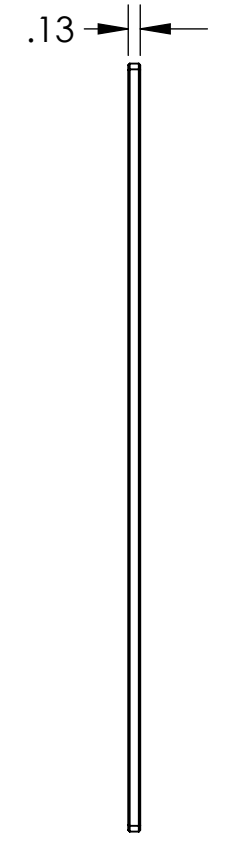
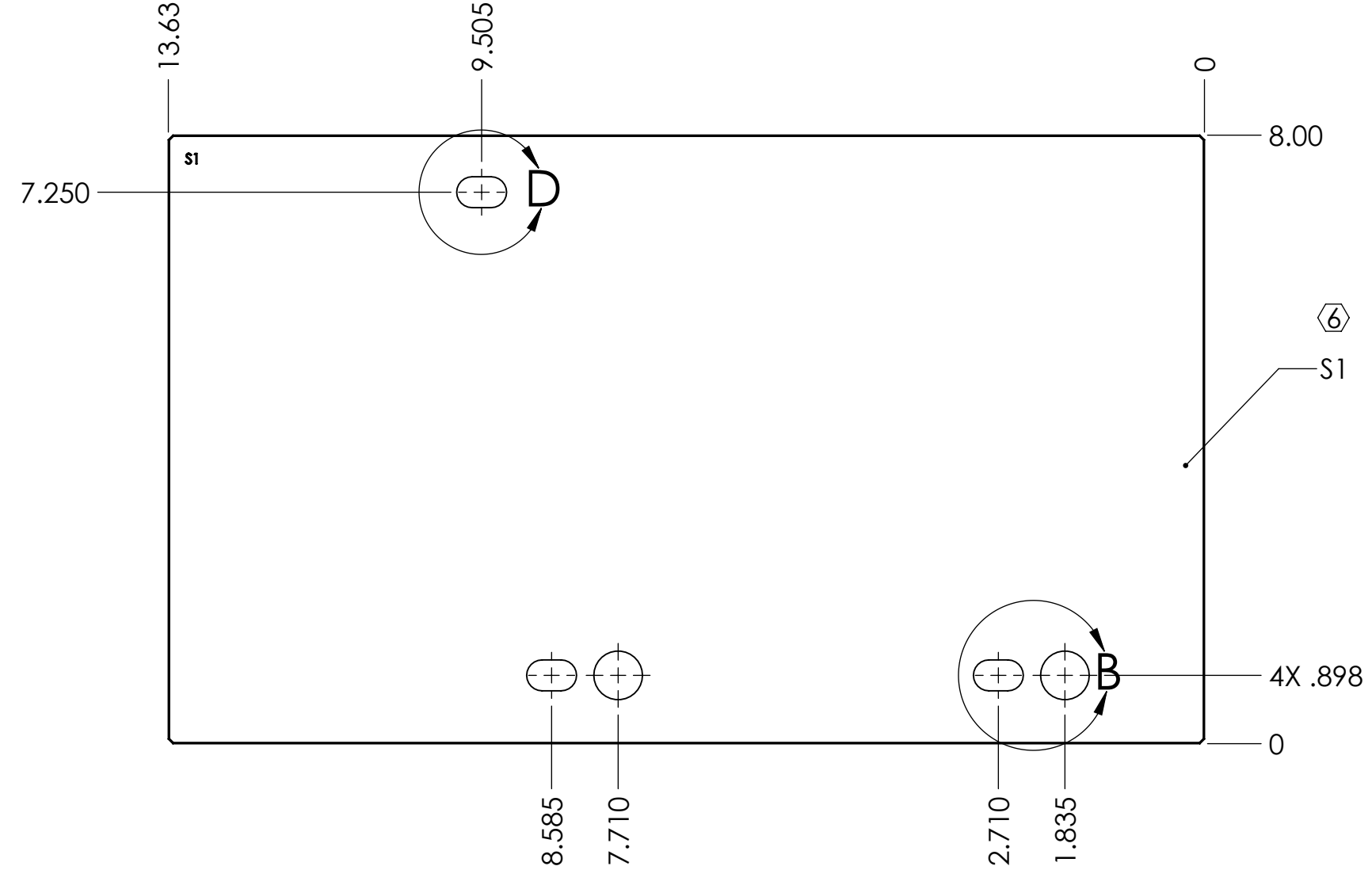
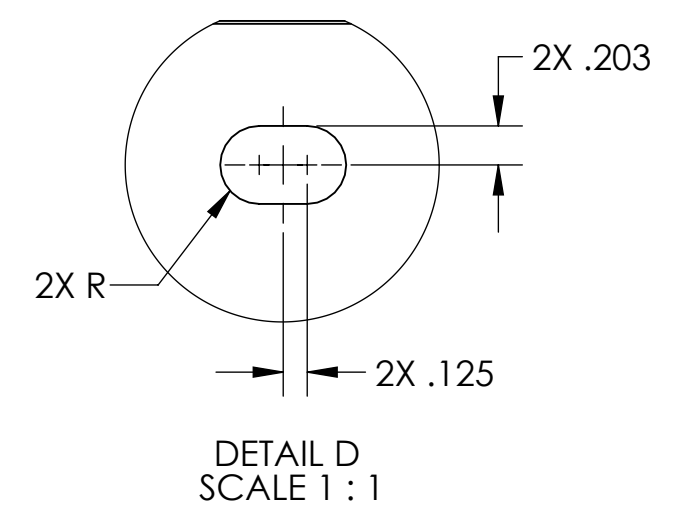
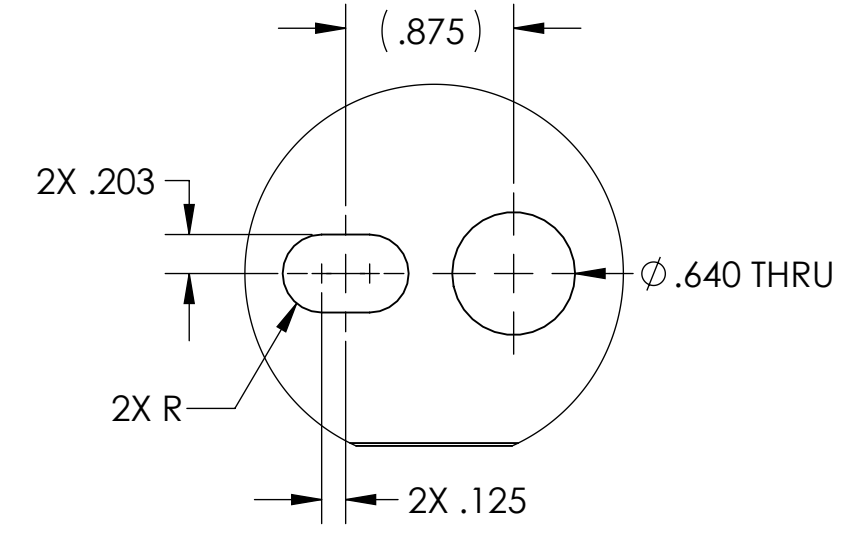

DETAIL F
SCALE 1 : 1

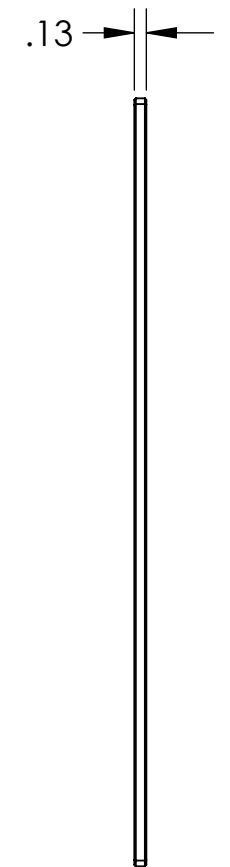
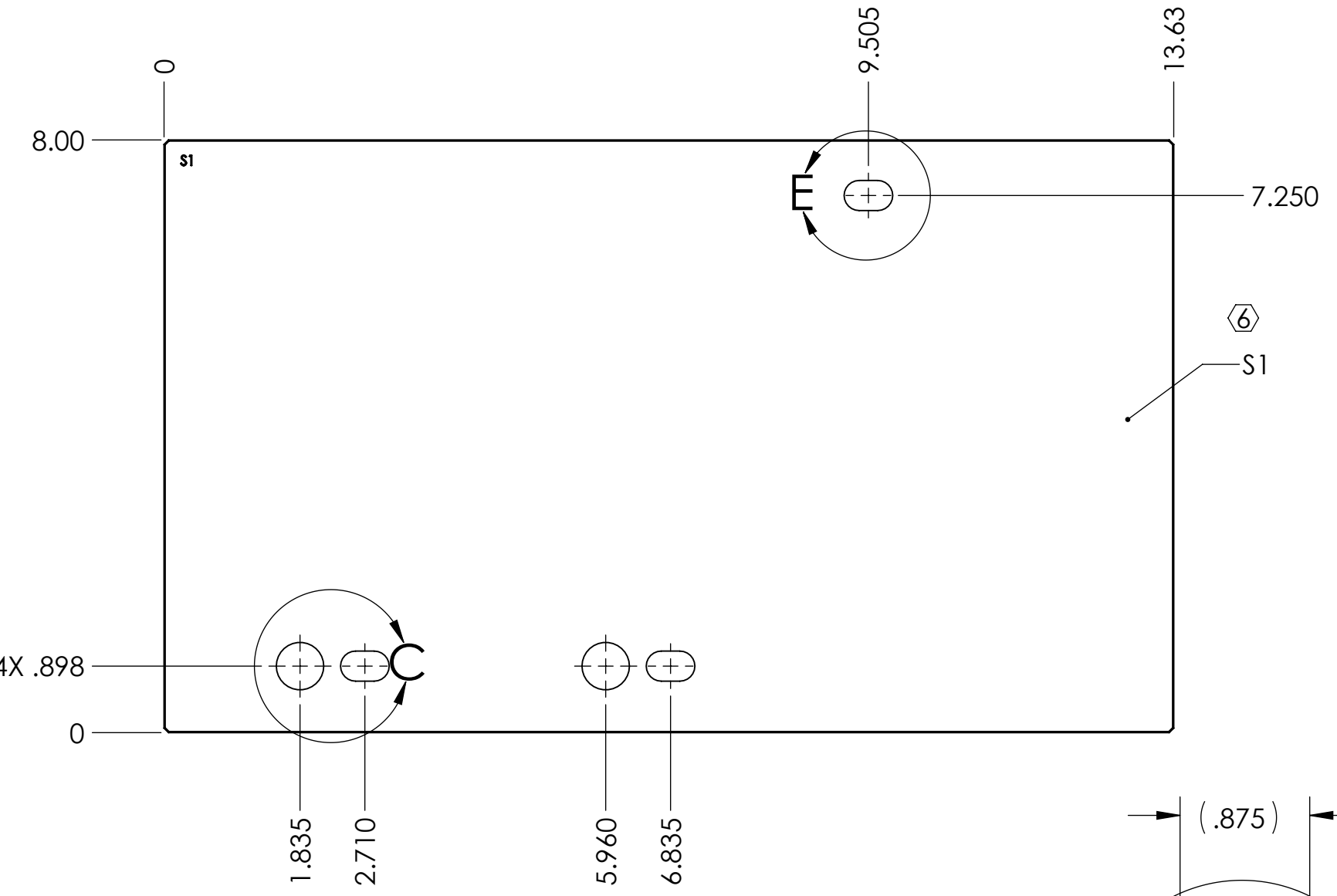
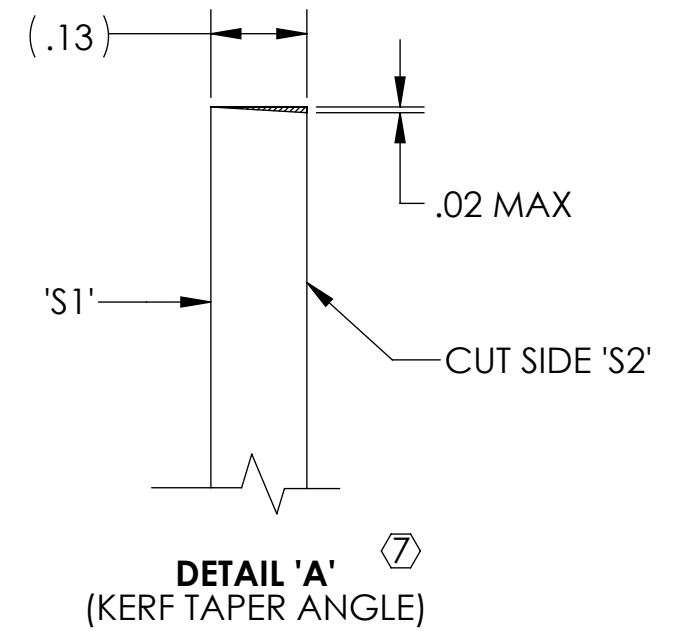

DETAIL G
SCALE 1 : 1

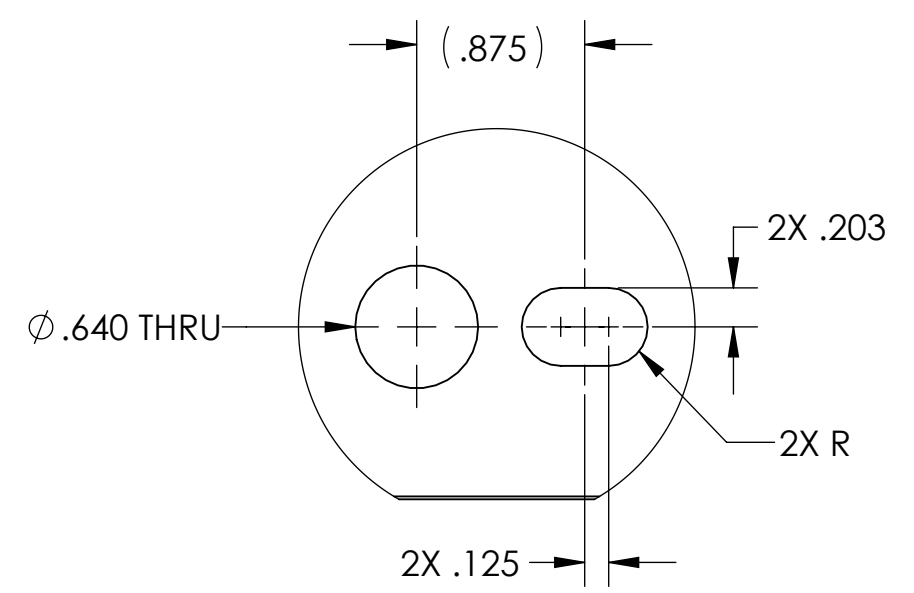
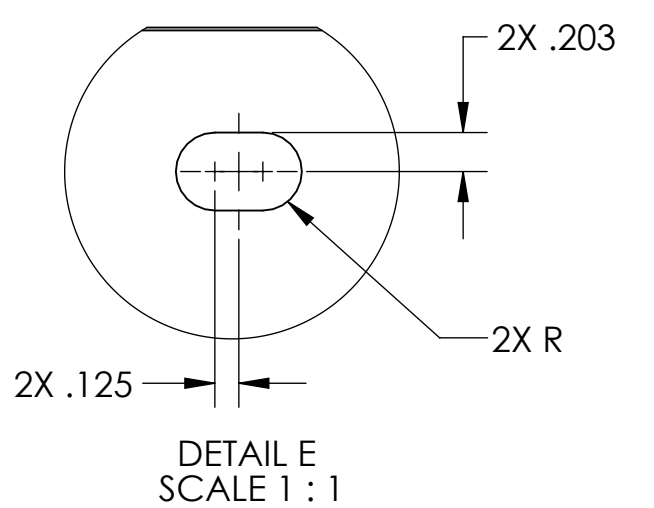

-102
(LEFT HAND)

NOTES AND TOLERANCES: (UNLESS OTHERWISE SPECIFIED)	
1. INTERPRET DRAWING PER ASME Y14.5-1994.	
2. REMOVE ALL SHARP EDGES, .005-.015, FOR MACHINED PARTS.	
3. DO NOT SCALE FROM DRAWING.	
4. ALL MACHINING FLUIDS MUST BE FULLY SYNTHETIC, FULLY WATER SOLUBLE AND FREE OF SULFUR, SILICONE, AND CHLORINE.	
DIMENSIONS ARE IN INCHES	
TOLERANCES:	
.XX ± .02	
.XXX ± .015	
ANGULAR ± 1.0°	
MATERIAL	SEE NOTE 6
FINISH	N/A μinch

LIGO CALIFORNIA INSTITUTE OF TECHNOLOGY
 MASSACHUSETTS INSTITUTE OF TECHNOLOGY

SYSTEM: ADVANCED LIGO SUB-SYSTEM: AOS

NEXT ASSY: D0900295

PART NAME		DRAWING NO.		REV.
aLIGO, OMC, Stray light baffle, Outer Panel (-X Side)		D		v2
DESIGNER	E.SANCHEZ	DATE	22 JAN 2015	SIZE
DRAFTER	E.SANCHEZ	DATE	06 FEB 2015	DWG. NO.
CHECKER	SEE DCC	DATE	SEE DCC	D1500042
APPROVAL	SEE DCC	DATE	SEE DCC	
SCALE:	1:2	PROJECTION:	FIRST ANGLE	
				SHEET 1 OF 1

D1500042-010-OMC, Stray light baffle, Outer Panel (-X Side), PART PDM REV: X-009, DRAWING PDM REV: X-002