



# Orthogonal Sensor and Actuator, and Automatic Alignment of High Finesse Optical Ring Cavity

by

Andres Medina

Mentors: Dr. Nicolás Smith and Dr. Gabriele Vajente

## Gravitational Wave Detector

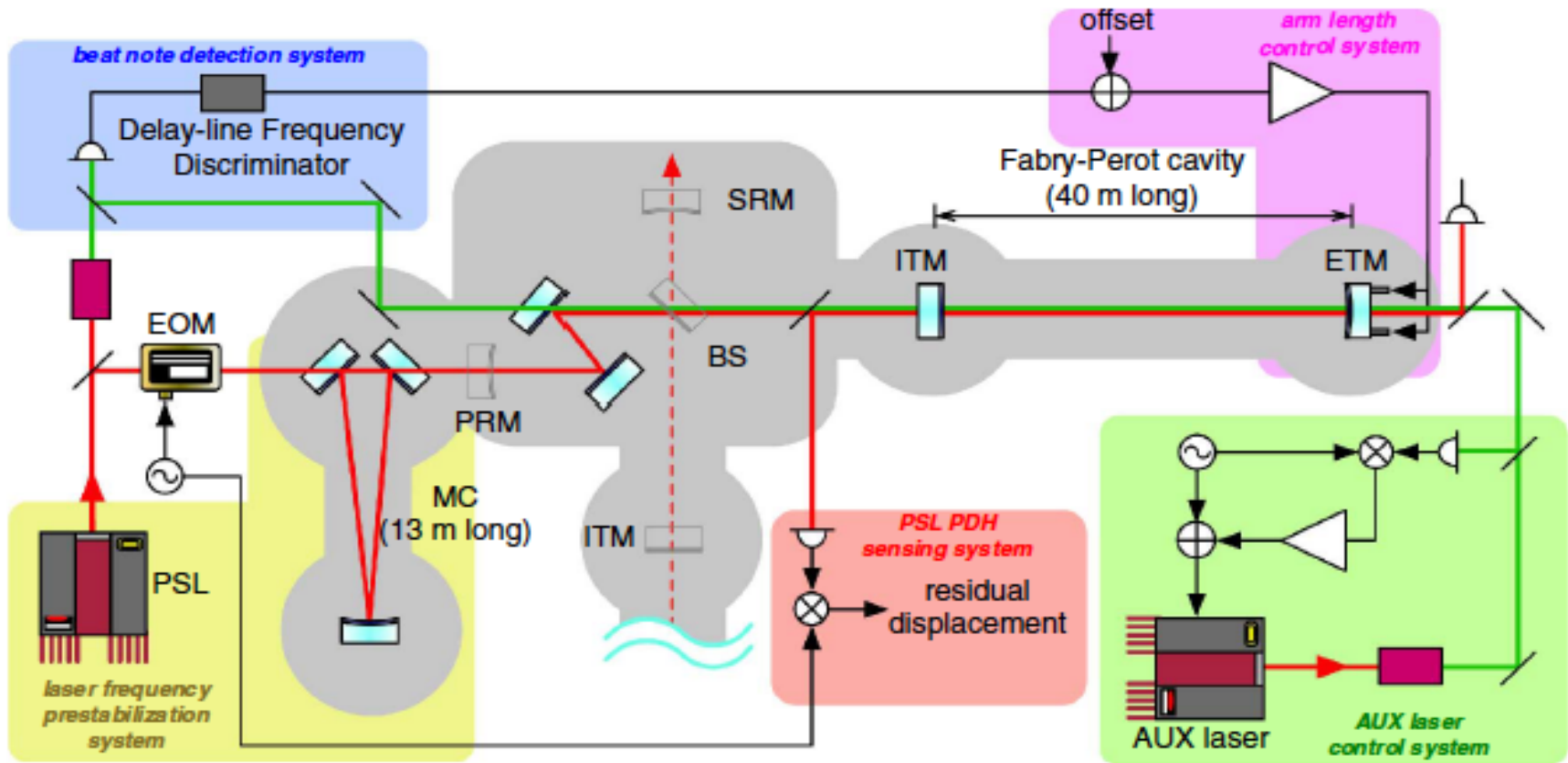

= vacuum system   
  = photo detector   
  = oscillator   
  = frequency mixer   
  = servo filter   
  = SHG

**LIGO II**



# Gaussian Beam and its Properties

## Paraxial Wave Equation

$$[\nabla^2 + k^2] \vec{E}(x, y, z) = 0$$

$$\frac{1}{\tilde{q}(z)} = \frac{1}{R(z)} - j \frac{\lambda}{\pi w^2(z)}$$

$$w^2(z) = w_0^2 \left[ 1 + \left( \frac{\lambda z}{\pi w_0^2} \right)^2 \right]$$

$$R(z) = z \left[ 1 + \left( \frac{\pi w_0^2}{\lambda z} \right)^2 \right]$$

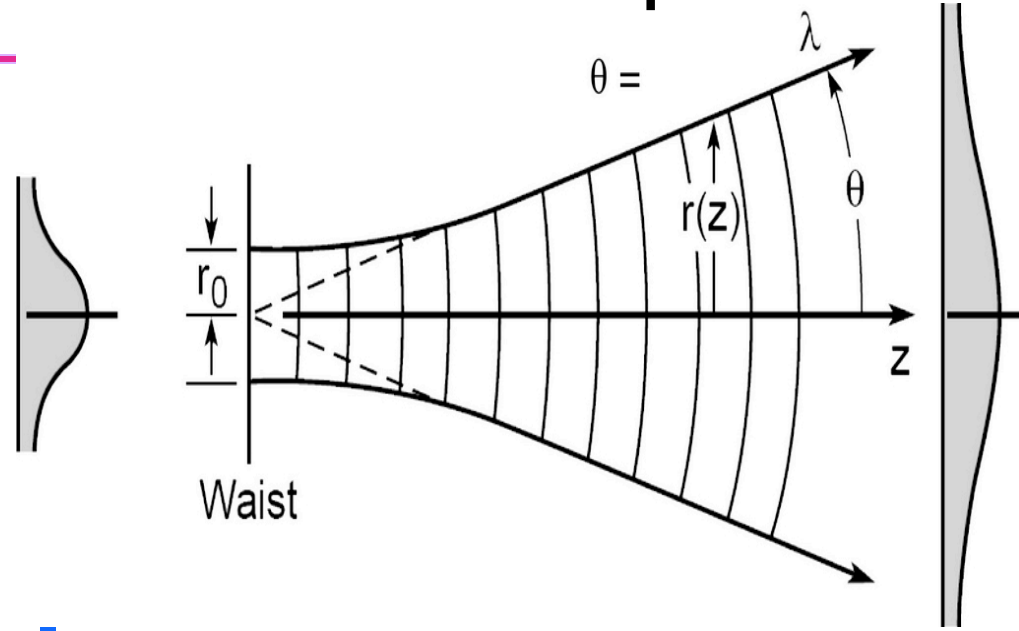

## ABCD Matrix

$$q = \frac{Aq_0 + B}{Cq_0 + D} \quad \Bigg| \quad M = \begin{bmatrix} A & B \\ C & D \end{bmatrix}$$

# Mode Matching

## Amplitude Coupling

$$C = 2 \frac{\sqrt{z_{R1} z_{R2}}}{i(z_1 - z_2) + (z_{R1} + z_{R2})}$$

## Power Coupling

$$|C|^2 = 4 \frac{z_{R1} z_{R2}}{(z_1 - z_2)^2 + (z_{R1} + z_{R2})^2}$$

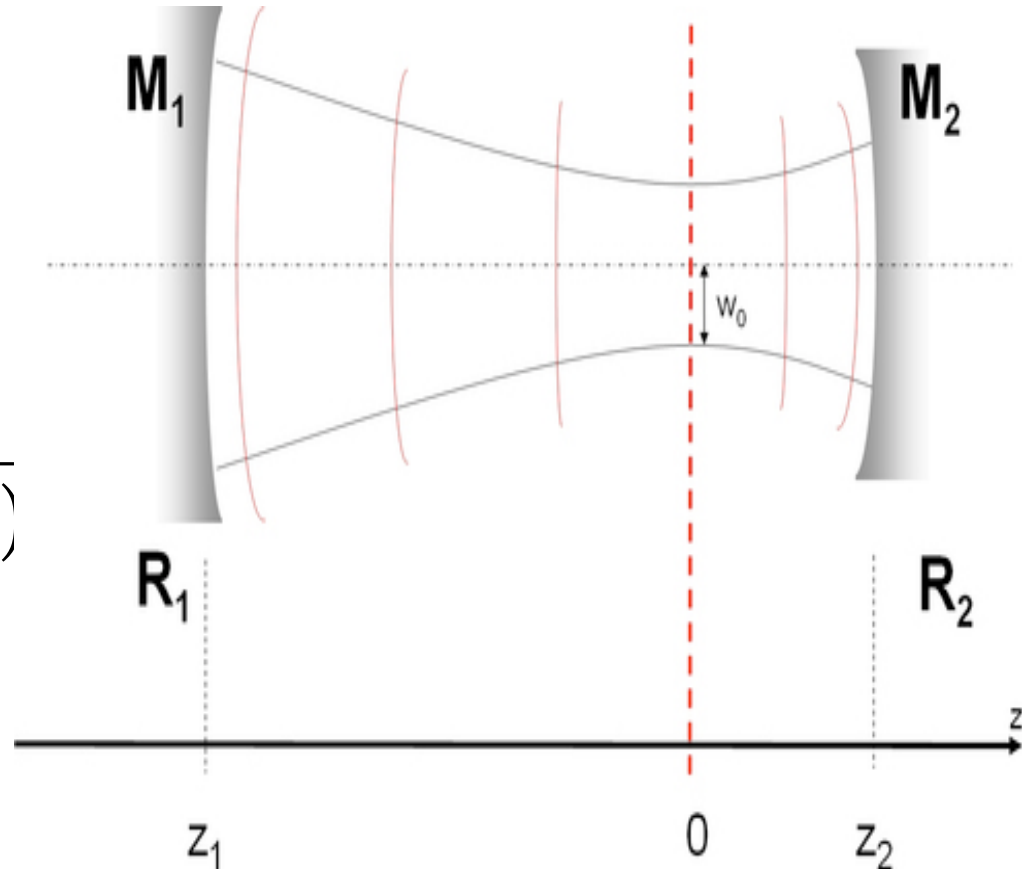

# Cavity Modes

## Hermite-Gaussian Modes

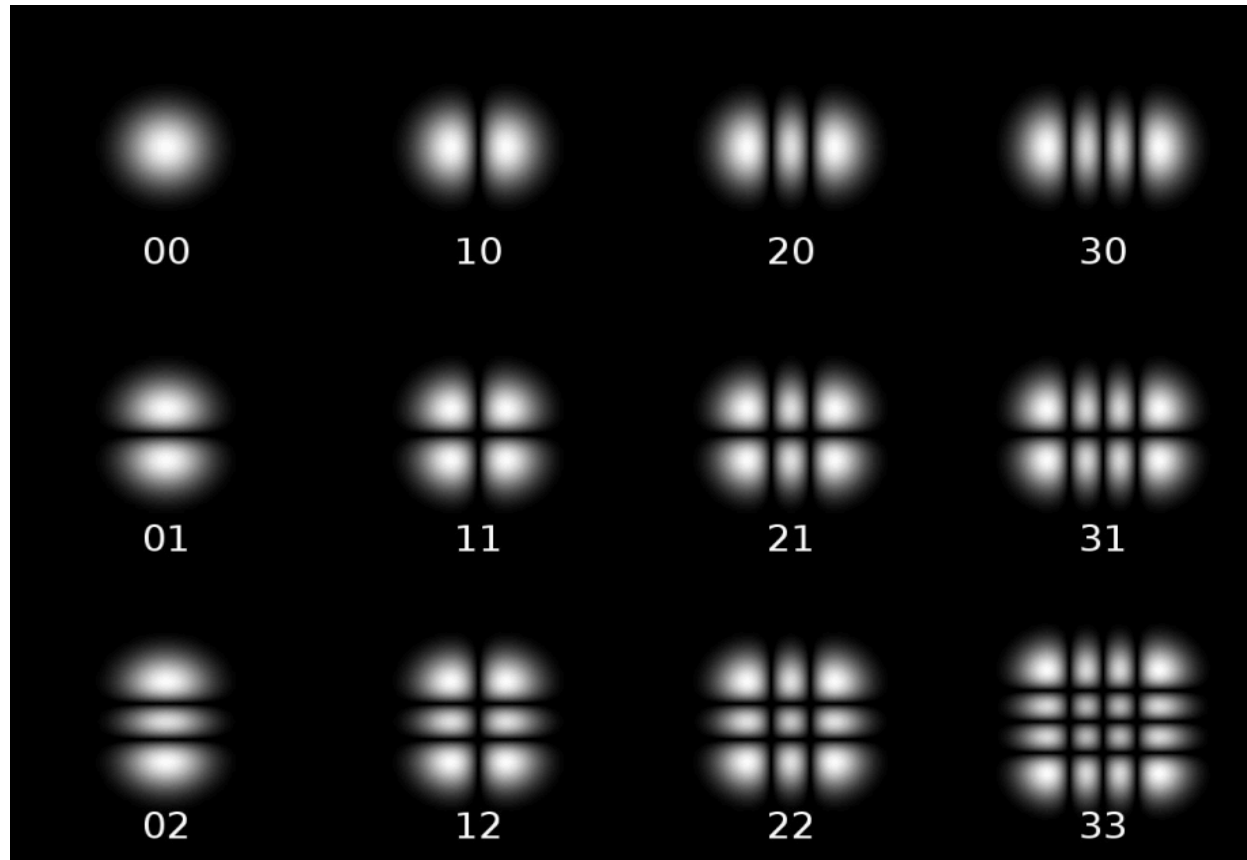

# Gouy Phase

## Gouy Phase vs $z/z_R$

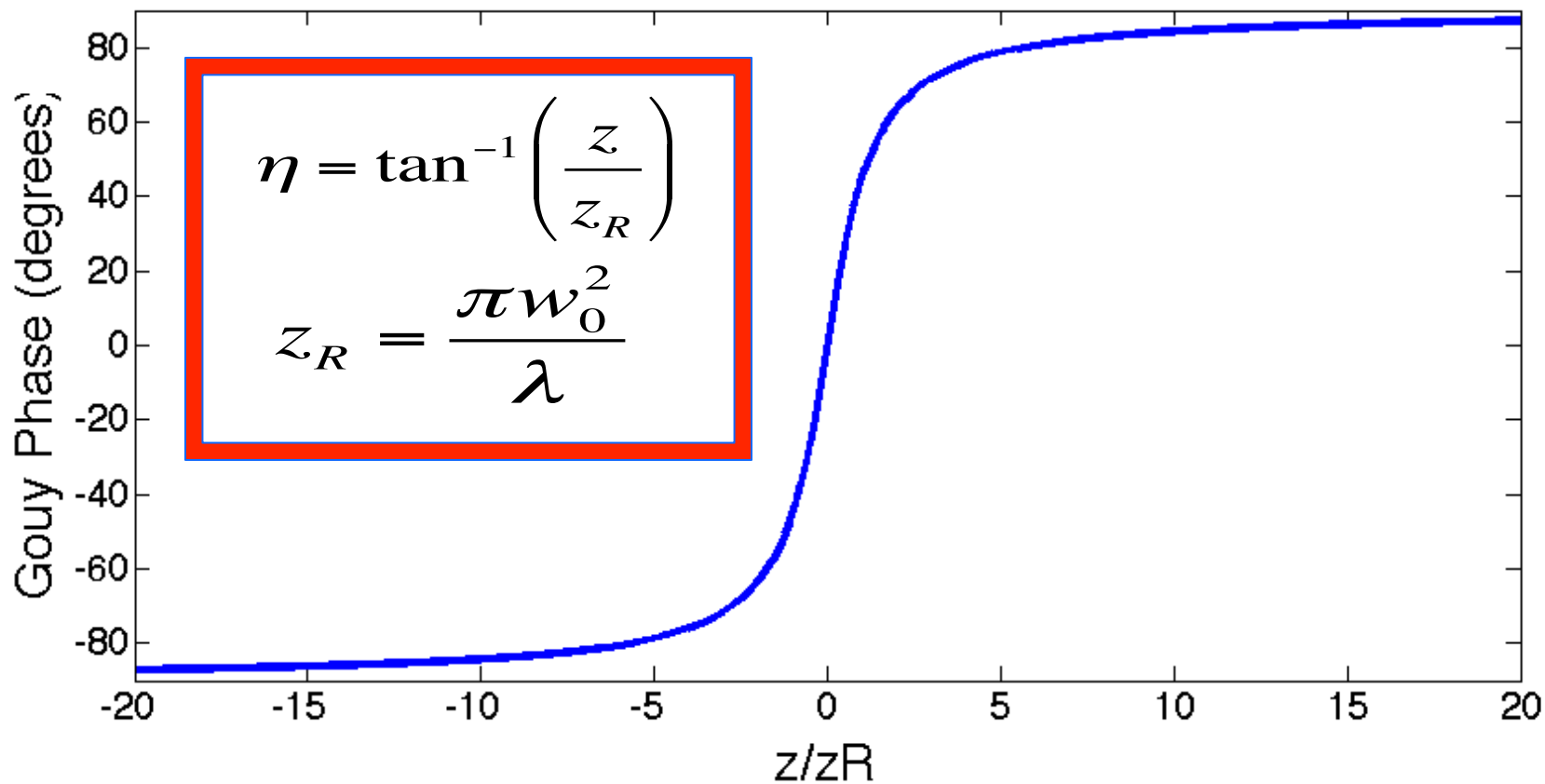

# Misalignment

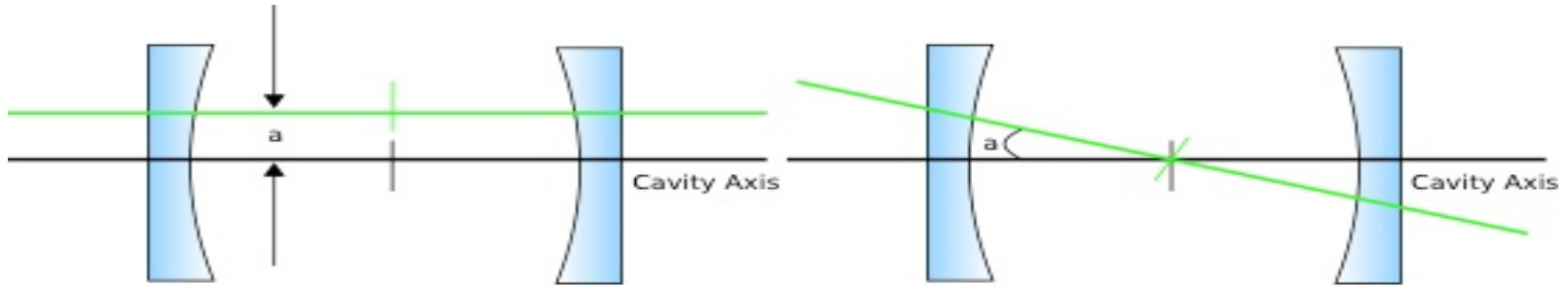

a) Transverse displacement in the x direction

b) Tilt through an angle  $a$

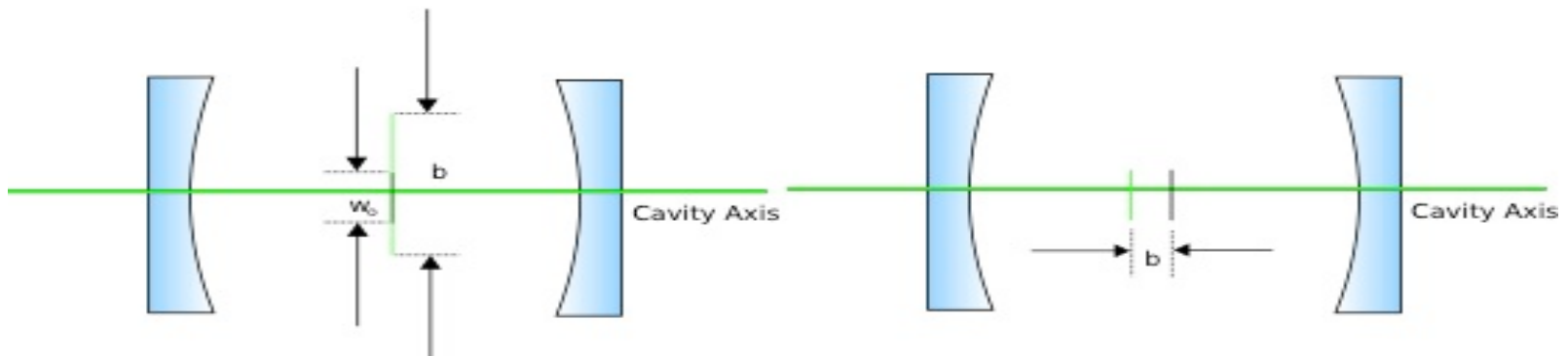

c) Waist size mismatch

d) Axial waist displacement

## Issues with Current Setup

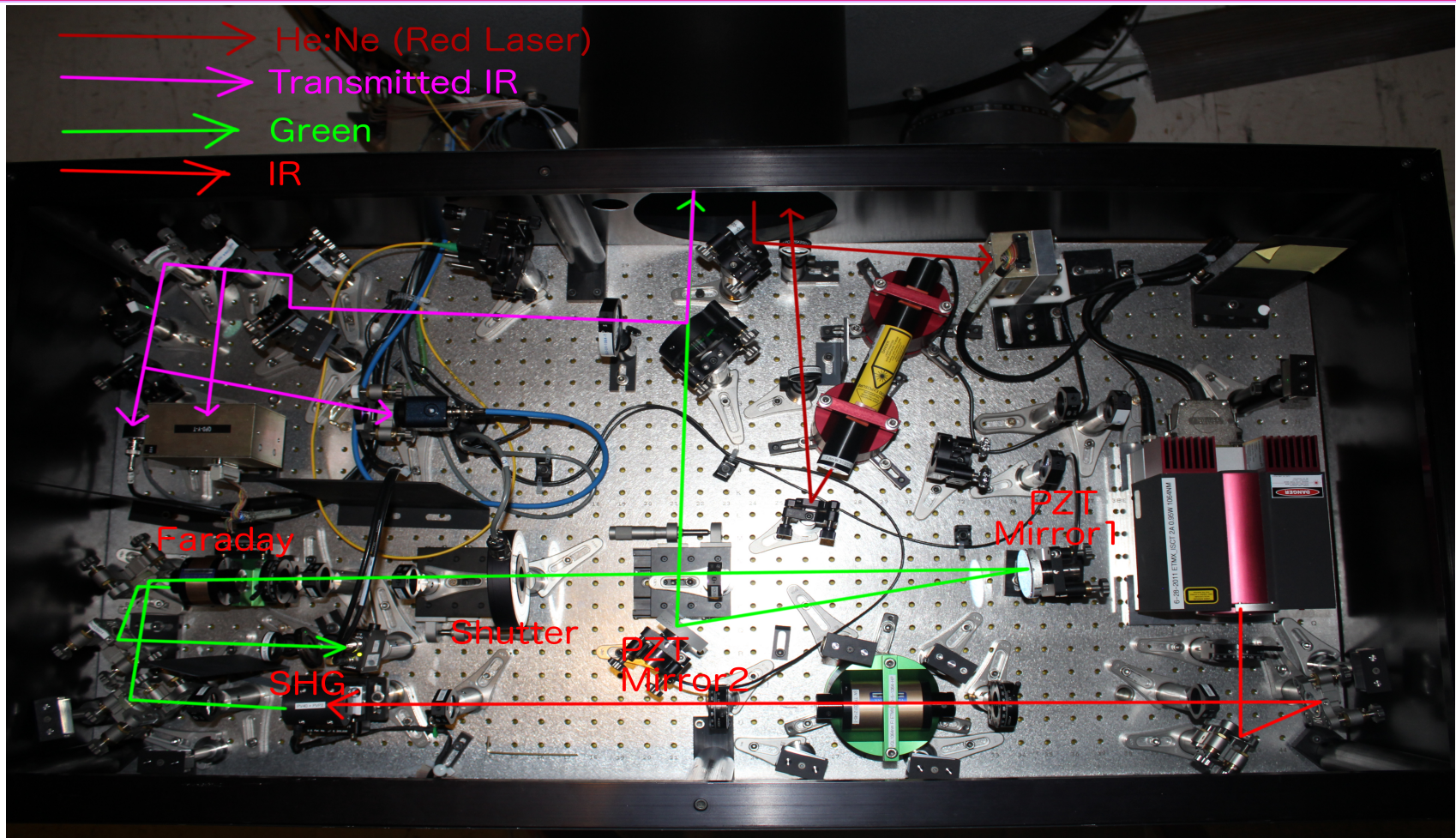

LIGO-G09xxxxx-V1

LIGO II

## Representation of the beam field

$$|E\rangle = |00\rangle + \left( \frac{\delta x}{w_0} + i \frac{\theta}{\theta_d} \right) |01\rangle$$

## Operator of the entire alignment System

$$M_B P M_A = \begin{bmatrix} 1 & -2i(e^{i\eta}\theta_A + \theta_B) \\ -2i(e^{i\eta}\theta_A + \theta_B) & e^{i\eta} \end{bmatrix}$$

$$|E\rangle_{out} = |00\rangle - 2i(e^{i\eta}\theta_A + \theta_B)|01\rangle$$



# Current Mode Matching

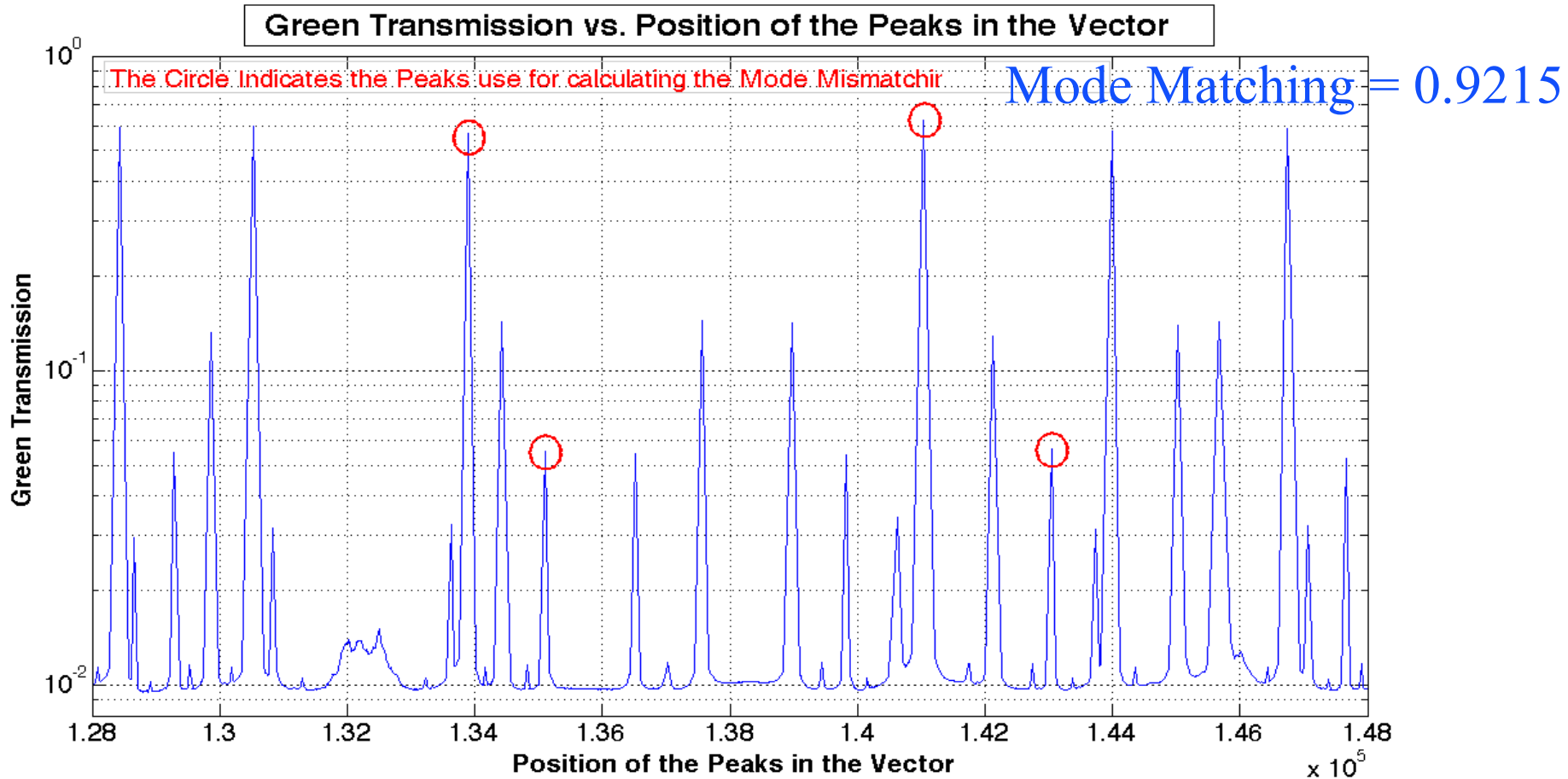

# Predicted Mode Matching and Gouy Phase

Beam Path Summary:

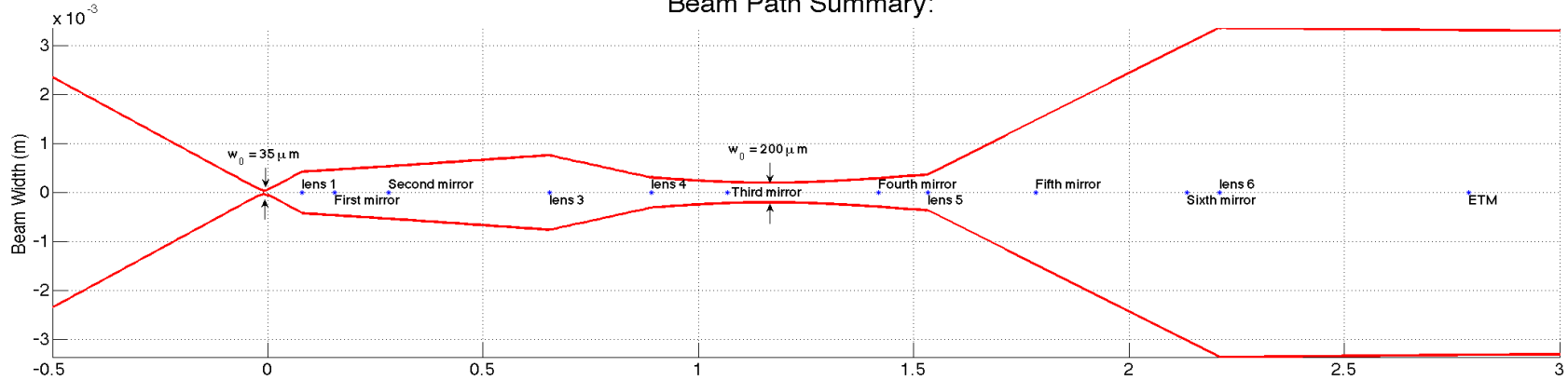

Gouy Phase =  $85.23^\circ$

Mode Matching = 0.99144

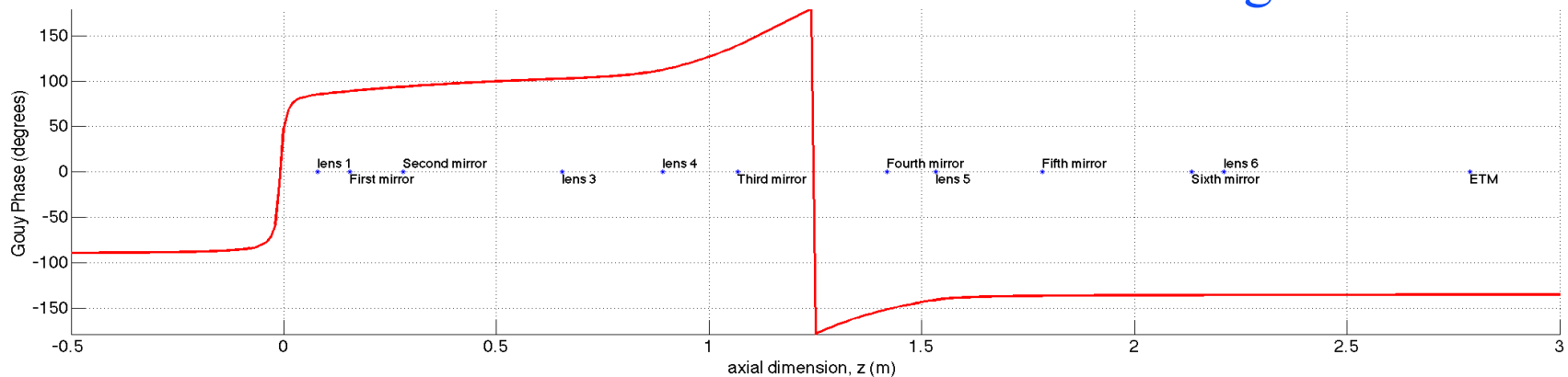

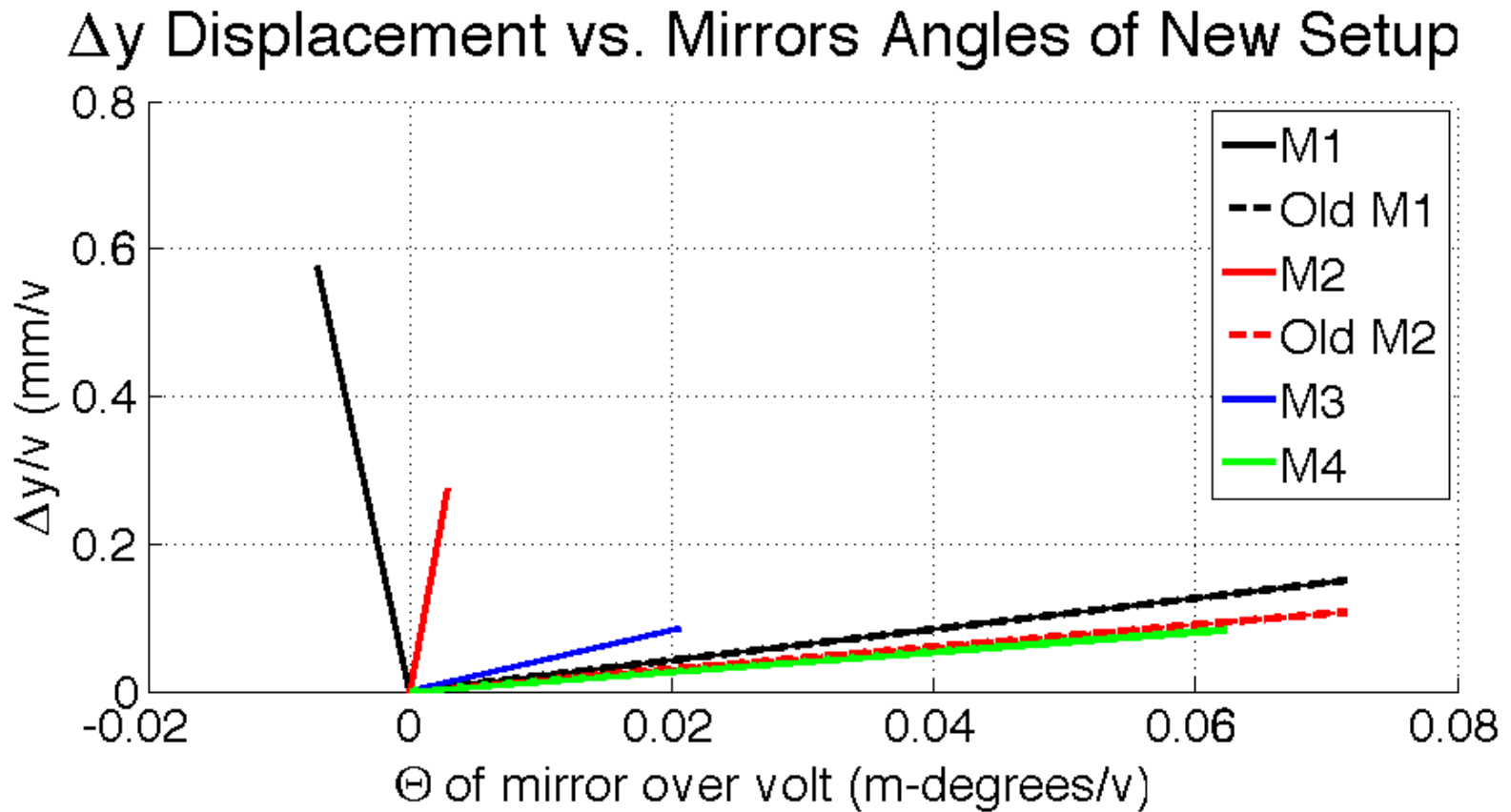

## New Optical Table Setup

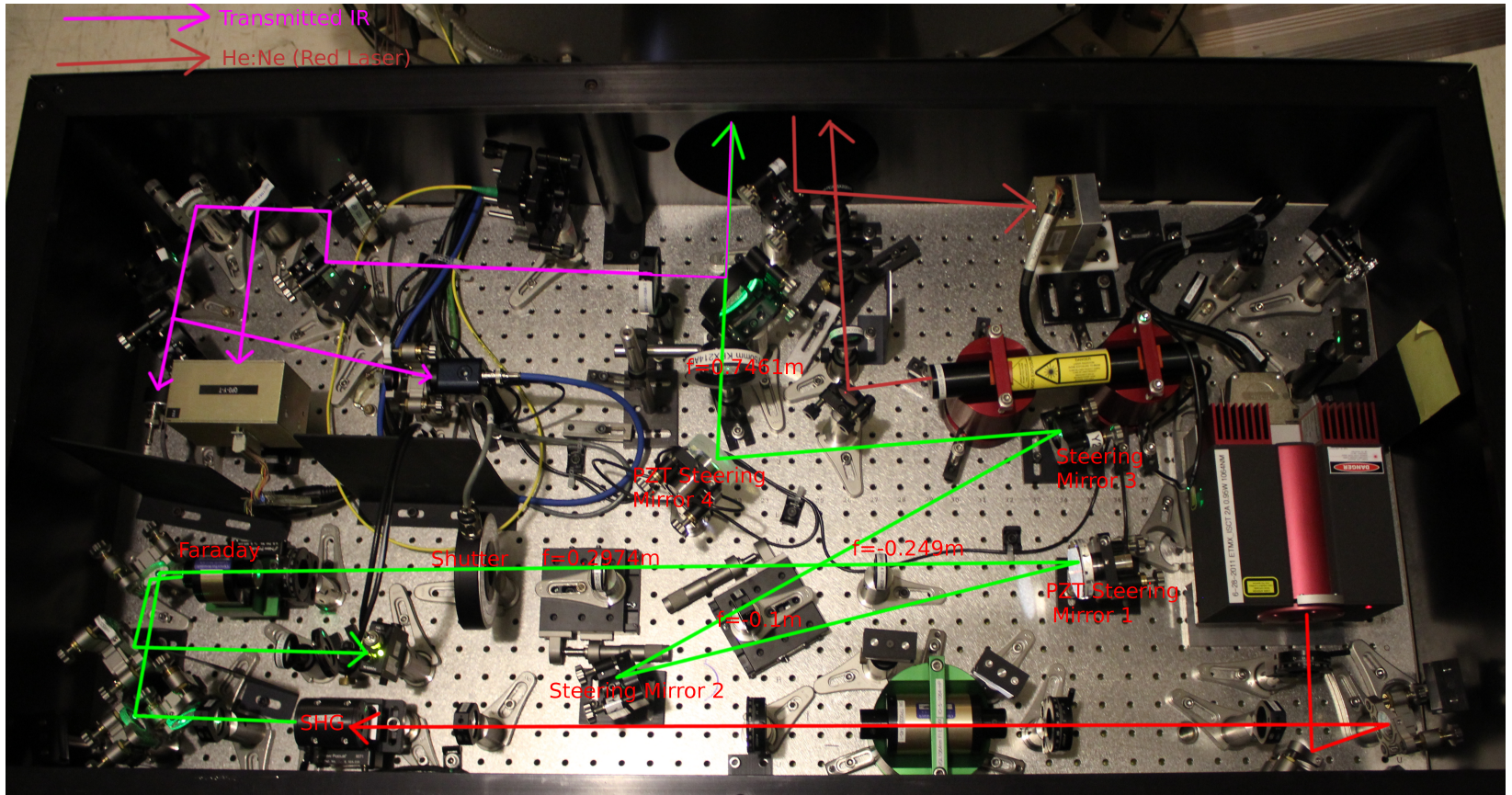

LIGO-G09xxxxx-v1

# Matrix Sensing

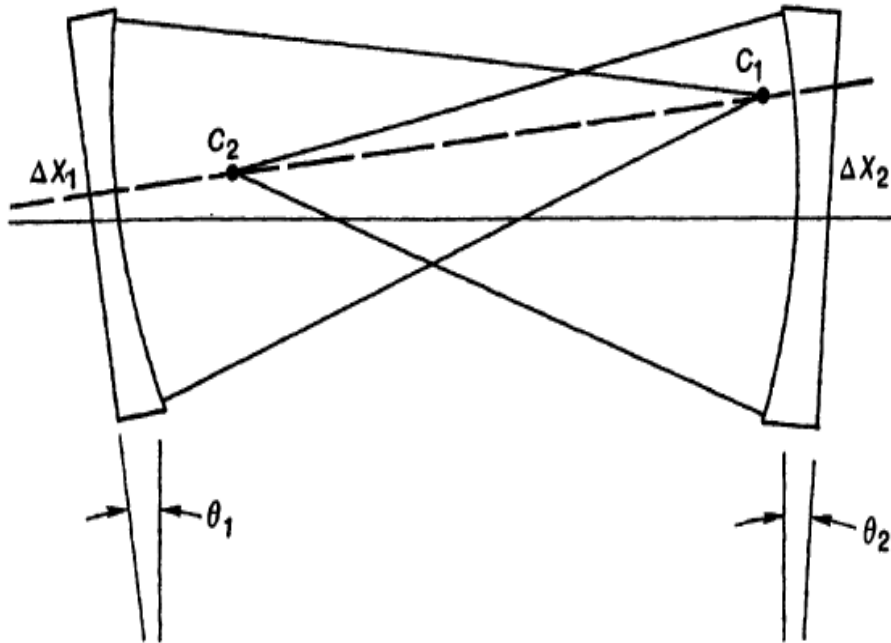

$$\Delta x_1 = \frac{g_2}{1 - g_1 g_2} d\theta_1 + \frac{1}{1 - g_1 g_2} d\theta_2$$

$$\Delta x_2 = \frac{1}{1 - g_1 g_2} d\theta_1 + \frac{g_1}{1 - g_1 g_2} d\theta_2$$

$$\Delta \theta \equiv \frac{(1 - g_2)\theta_1 - (1 - g_1)\theta_2}{1 - g_1 g_2}$$

# Matrix Sensing

$$\begin{bmatrix} x_1 \\ x_2 \end{bmatrix} = \mathbf{M}_S \begin{bmatrix} \theta_1 \\ \theta_2 \end{bmatrix}$$

$$\begin{bmatrix} x_1 \\ x_2 \end{bmatrix} = \begin{bmatrix} \frac{g_2}{1 - g_1 g_2} d & \frac{1}{1 - g_1 g_2} d \\ \frac{1}{1 - g_1 g_2} d & \frac{g_1}{1 - g_1 g_2} d \end{bmatrix} \begin{bmatrix} \theta_1 \\ \theta_2 \end{bmatrix}$$

# Input Mode Cleaner

## Mode Cleaner Configuration

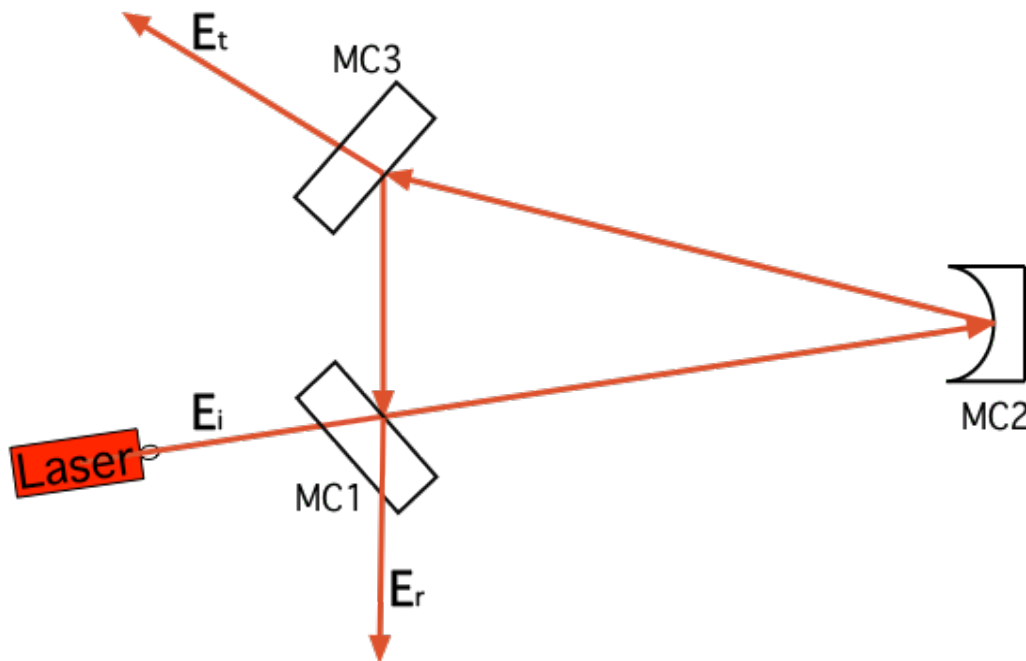



# Current Setup and its Gouy Phase

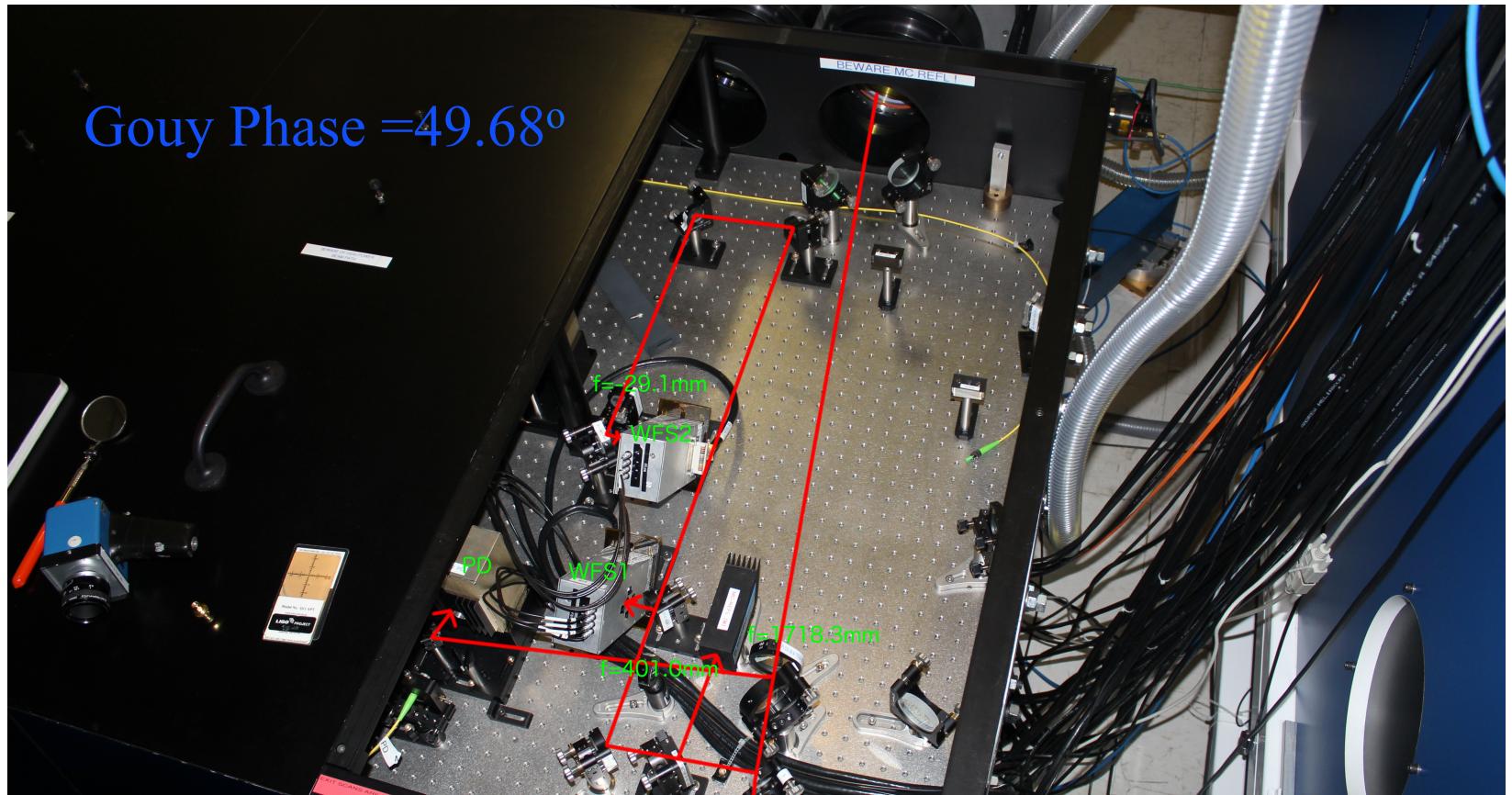

LIGO-G09xxxxx-v1

LIGO II



# New Optical Setup and its predicted Gouy Phase

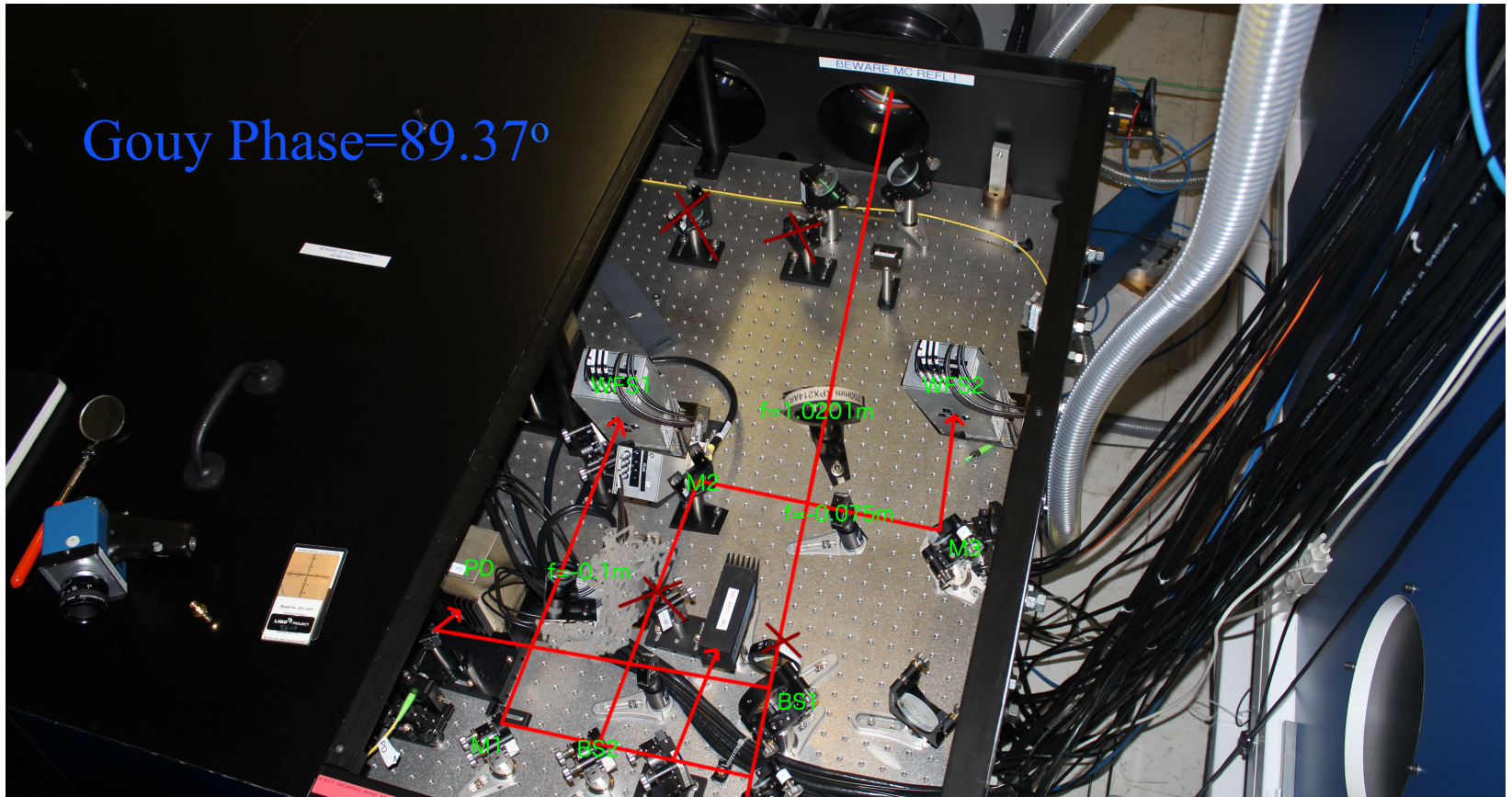

LIGO-G09xxxxx-v1

# Future Plan

---

- Characterize the Xarm Green upgrade, which include measuring how perpendicular the PZTs mirrors are, measure the mode matching
- We need to implement the new optical table layout for the IMC
- The control negative feedback system need to be upgrade so that it keep the mode cleaner lock
- Characterize IMC

# Acknowledgements & Thanks

---

- Nick and Gabriele
- 40m Team
- My Surf teammates
- Caltech LIGO
- NSF

# Back Up Slides

## Solution of the Wave Equation

$$\tilde{u}(x, y, z) = \frac{1}{\tilde{q}(z)} \exp \left[ -jk \frac{x^2 + y^2}{2R(z)} - \frac{x^2 + y^2}{w^2(z)} \right]$$

## Mirror Operator

$$M_A = \begin{bmatrix} 1 & -2i\theta_A \\ -2i\theta_A & 1 \end{bmatrix}$$

## Propagation operator

$$P = e^{i\phi} \begin{bmatrix} 1 & 0 \\ 0 & e^{i\eta} \end{bmatrix}$$

# Pound Drever Hall Technique

