

Modeling of Type-A and prototype testing of VIS

Takanori Sekiguchi

Institute for **C**osmic **R**ay **R**esearch, **U**niversity of **T**okyo

Contents

- SAS Design Concept and Development Status
- Cryogenic Suspension System
- Modeling Approach
- Discussion

KAGRA-SAS (Type A & B)

Pre-isolator
(Inverted Pendulum Stage)

Geometric Anti-Spring filters
(3 or 6 stages)

Payload
(Mirror Suspension)

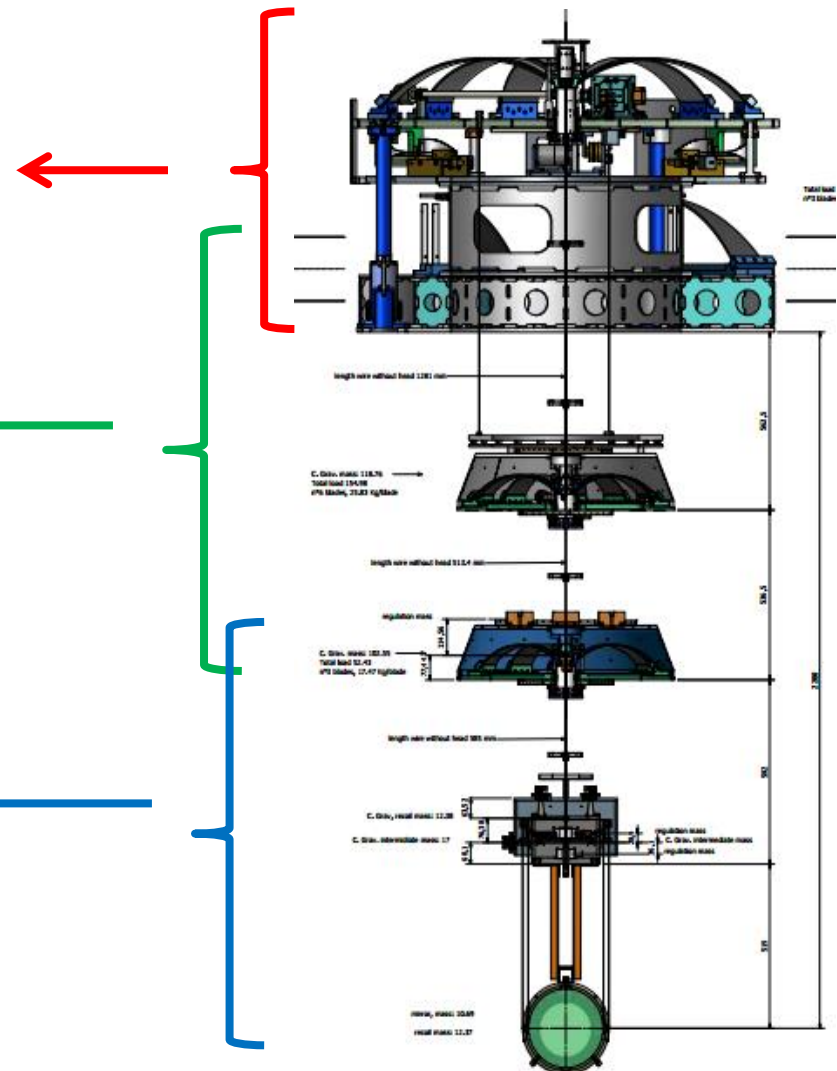

Pre-isolator

- Inverted pendulum (IP) stage provides attenuation of micro-seismic peak and controllability of mirror position.

Motorized blade spring for DC positioning

Accelerometer
(Replaced by L-4C Geophone now)

IP Legs

LVDT and Voice coil actuator

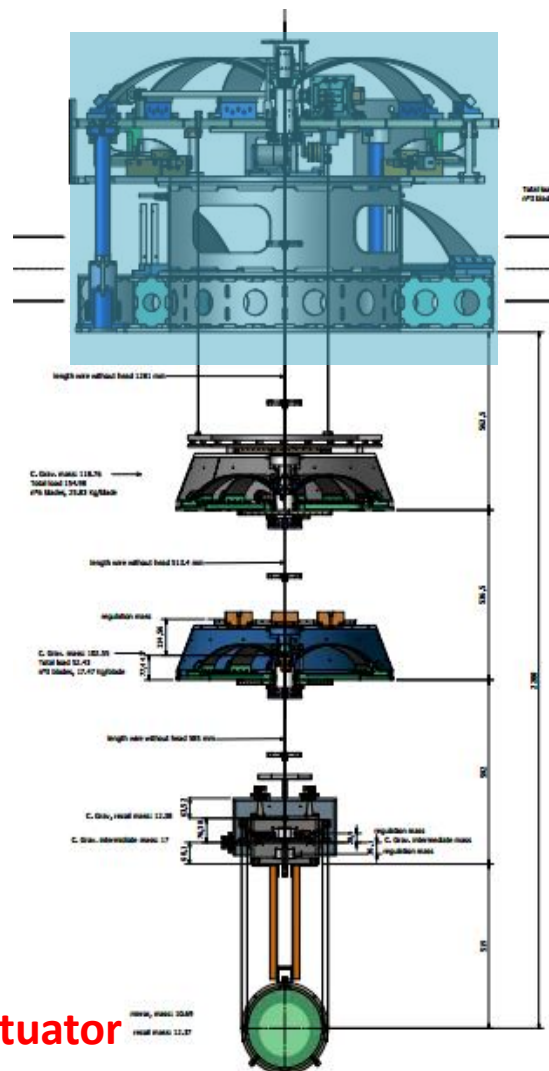
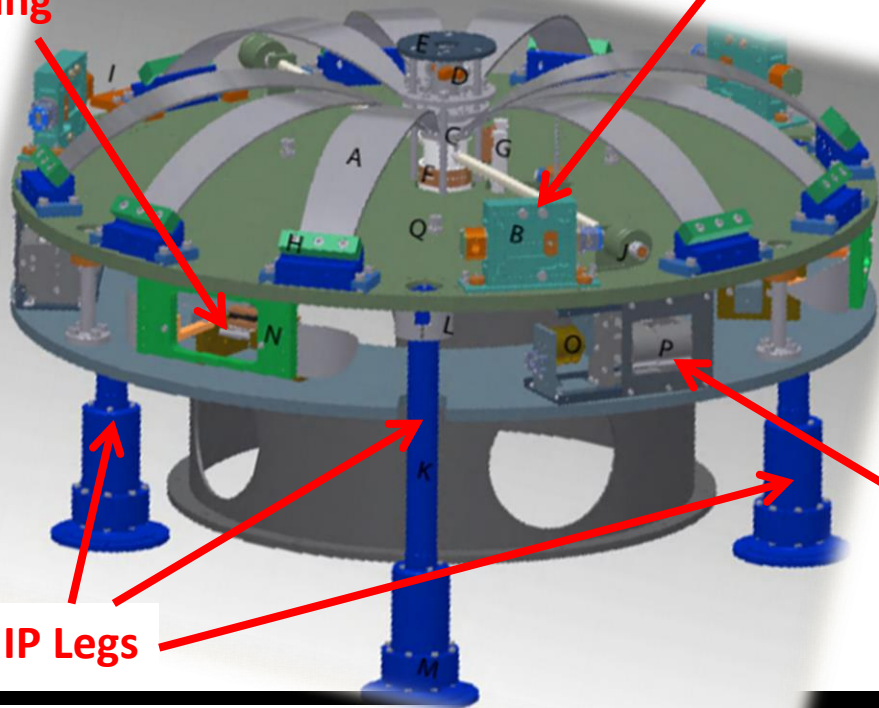

Active Control of IP

- Active control with combined sensors (LVDT + L-4C)
- Simulation and prototype experiment have been done.
- Further optimization of the control is necessary.

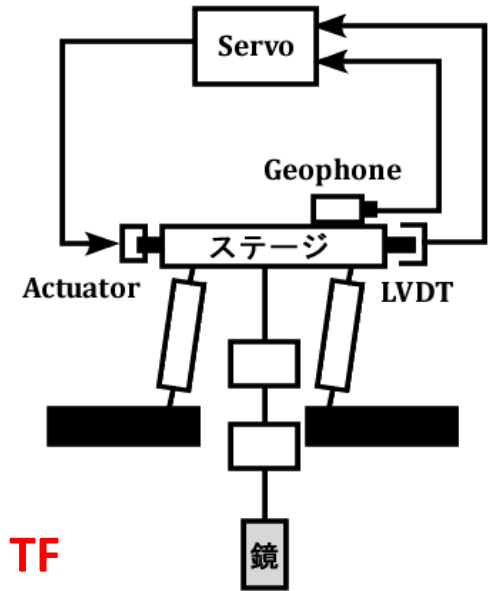

Servo filter design (preliminary)

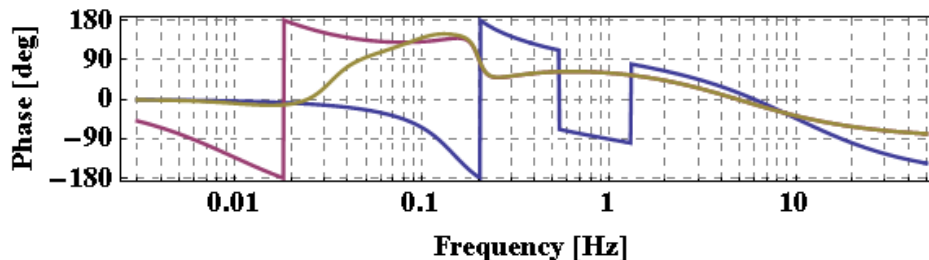
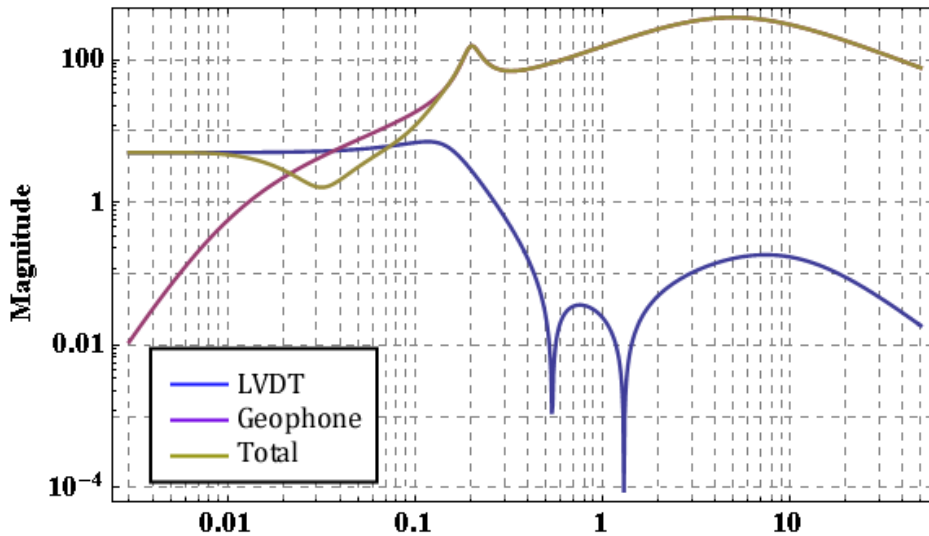

Open loop TF

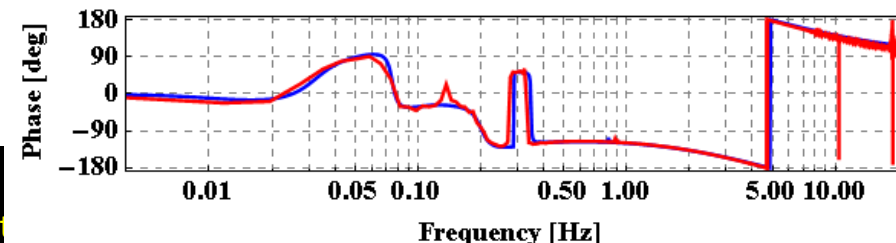
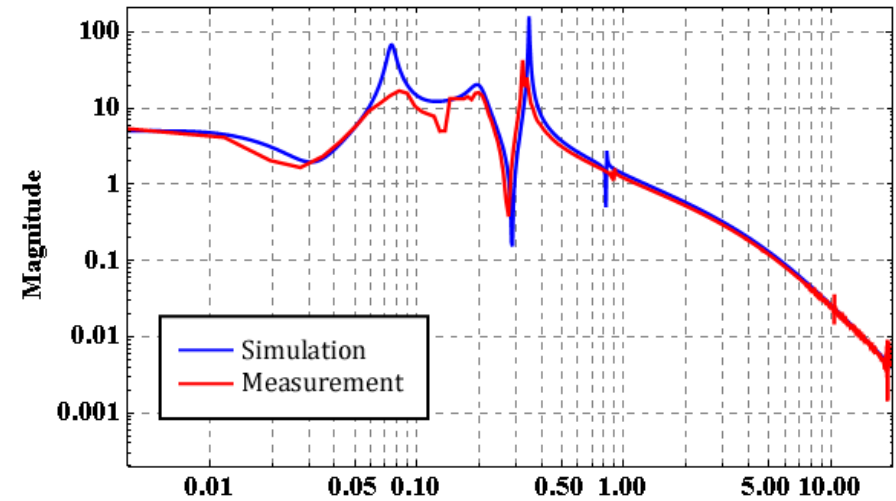

Geometric Anti-Spring (GAS) Filters

- Vertical springs tunable at as low frequency as ~ 0.25 Hz.
- Filters are suspended by single wires.

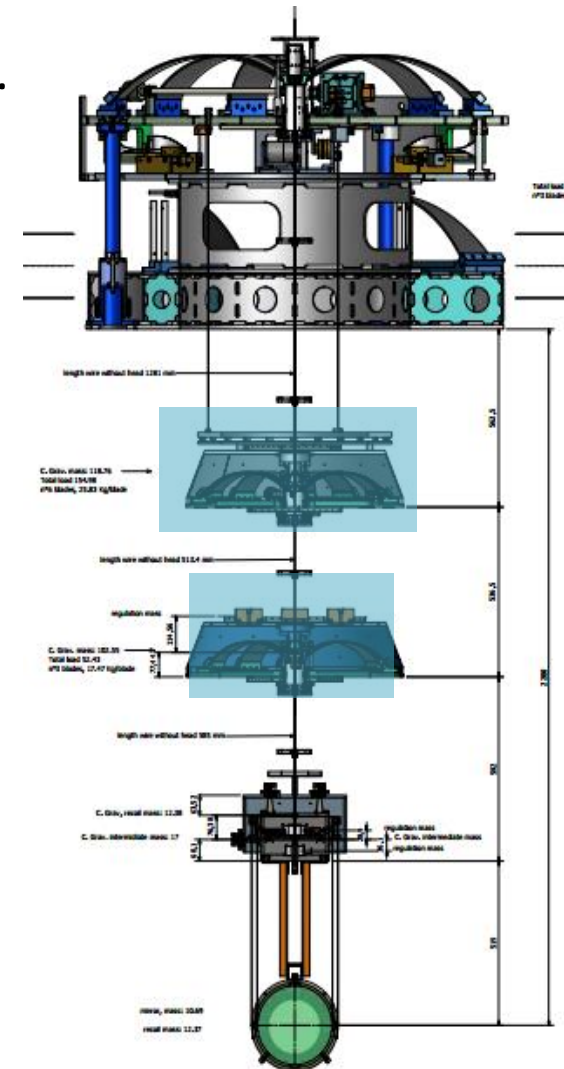
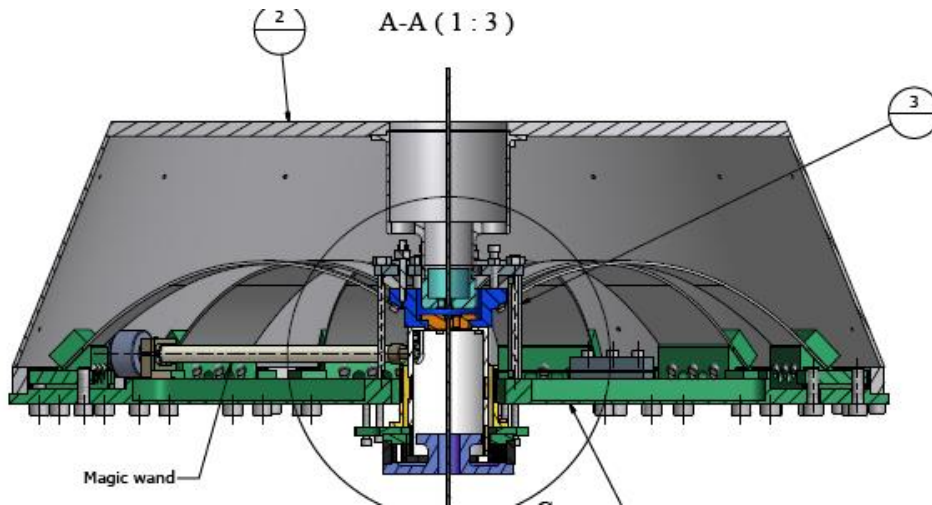

Torsion Mode Damping

- Large decay time of torsion modes has been a big problem in TAMA, Virgo.
- Passive eddy current damping is proposed.
- Simulation has been done, but verification by experiment is not yet;

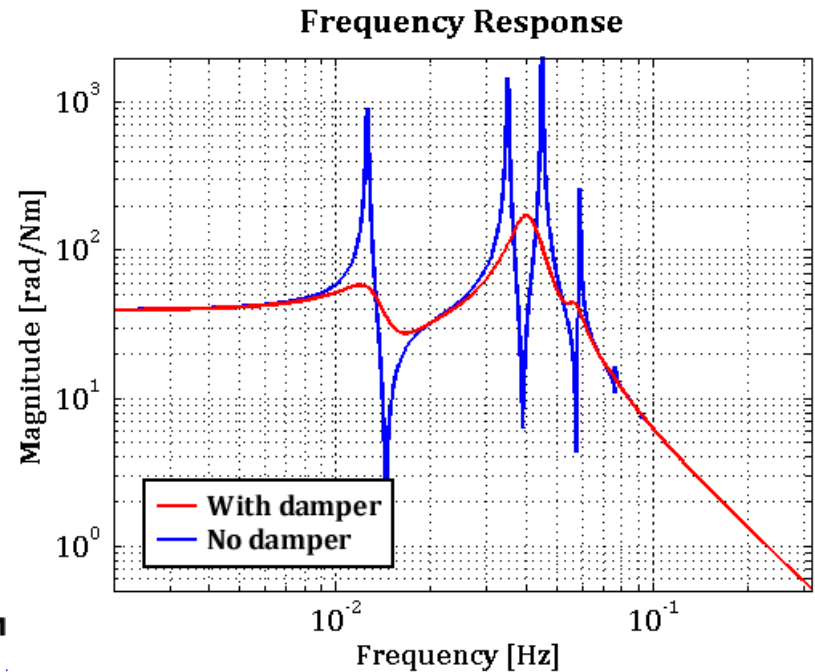
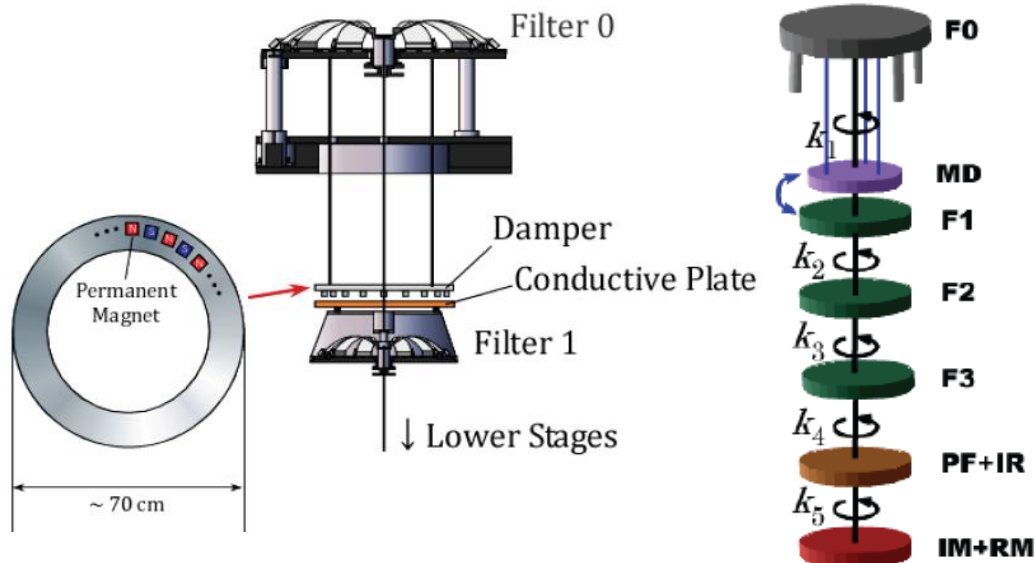

Payload

- Mirror suspension system with local sensors and actuators
- Mirror orientation and position is controlled at the intermediate stage.
- In type-B, **OSEMs** are used for the local control.

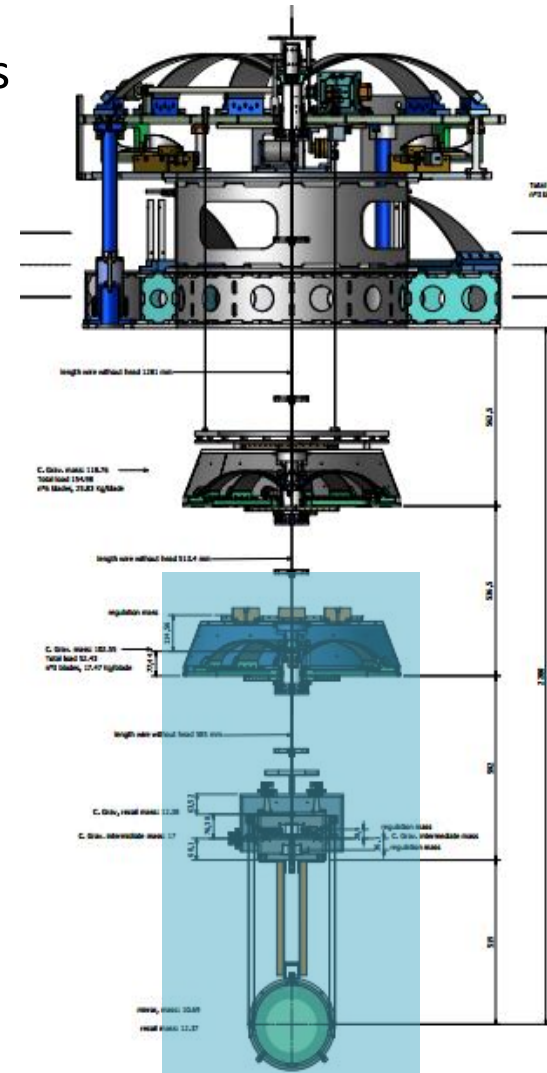
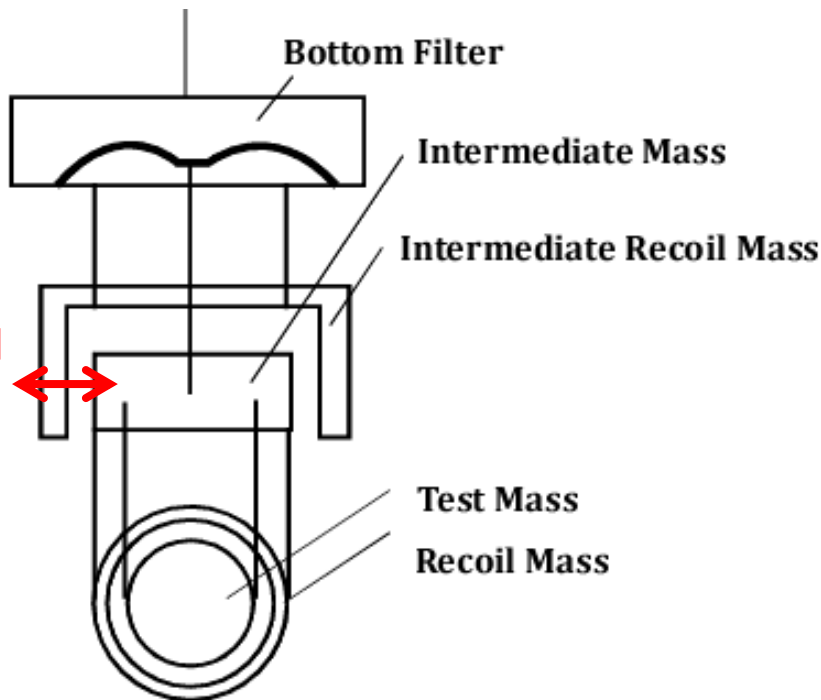

Prototype Testing Status & Plan

- **Pre-isolator**
 - In-air experiment of IP control, with combined sensor (LVDT +geophone) and LIGO digital system @ICRR
 - Test in vacuum is planned at 2014.2.
- **GAS filter**
 - Mechanical isolation performance is measured @NIKHEF
 - Torsion mode damping will be tested from 2014.2.
- **Type-B (Room Temperature) Payload**
 - Assembly test is on going @NAOJ.
 - Test of the optical lever is on going.
 - Control test with OSEMs will be performed soon.
- **Full Type-B prototype test will start from 2014.6.**

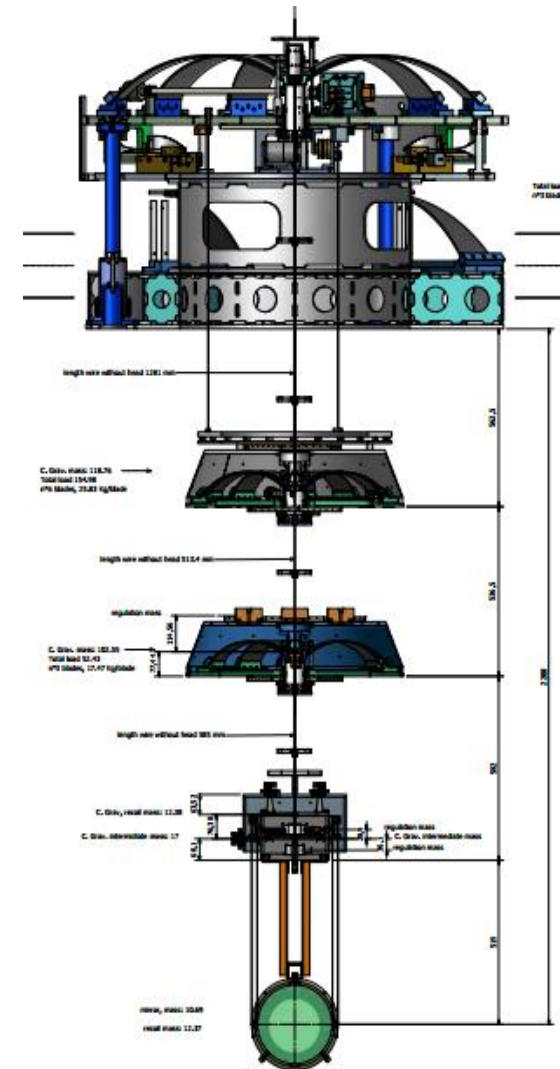

Prototype Testing Status & Plan

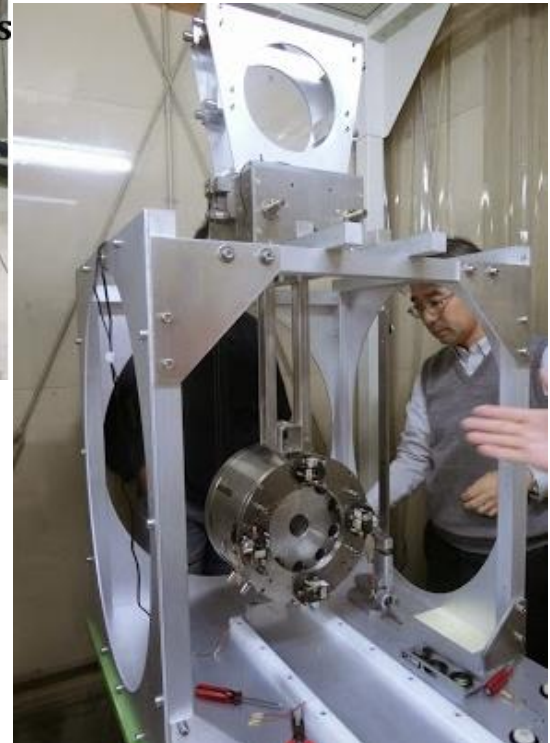
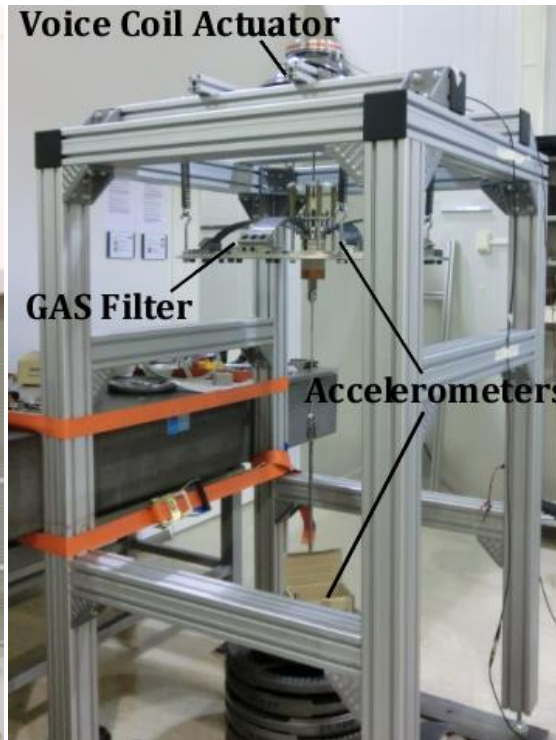

Cryogenic Payload

Type-A SAS and Cryogenic Payload

Scientific Requirement

- Sapphire mirror must be cooled down at **20K** (from mirror thermal noise requirement)
- Enough heat path must be prepared to subtract **~1 W** heat from laser absorption.
- Residual vibration noise (seismic noise + suspension thermal noise): **< 3×10^{-19} m/rtHz @10Hz**
- RMS requirement for IFO locking: **$0.1 \mu\text{m}/\text{sec}$ (TBC)**

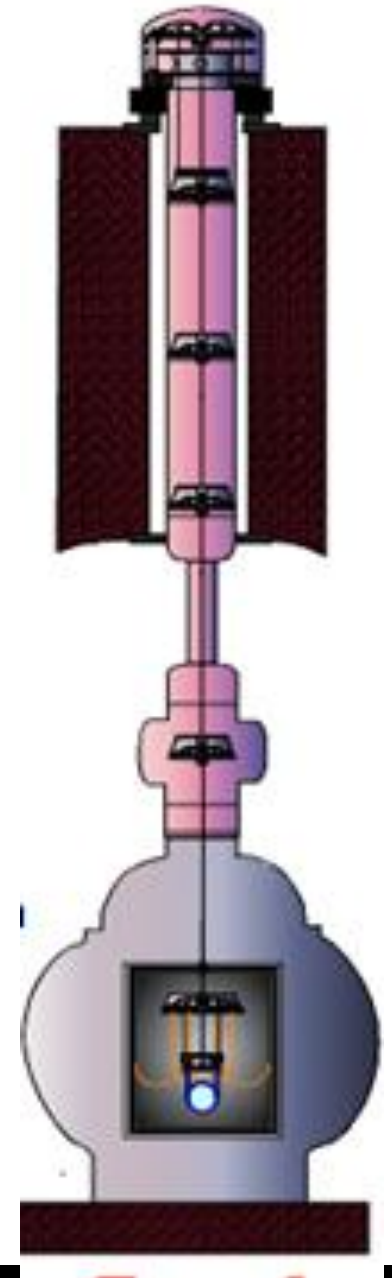

Cryogenic Payload Preliminary Design

- Triple pendulum
- Test mass is suspended by thick sapphire fibers for heat subtraction
- Heat links are connected from the cryocooler

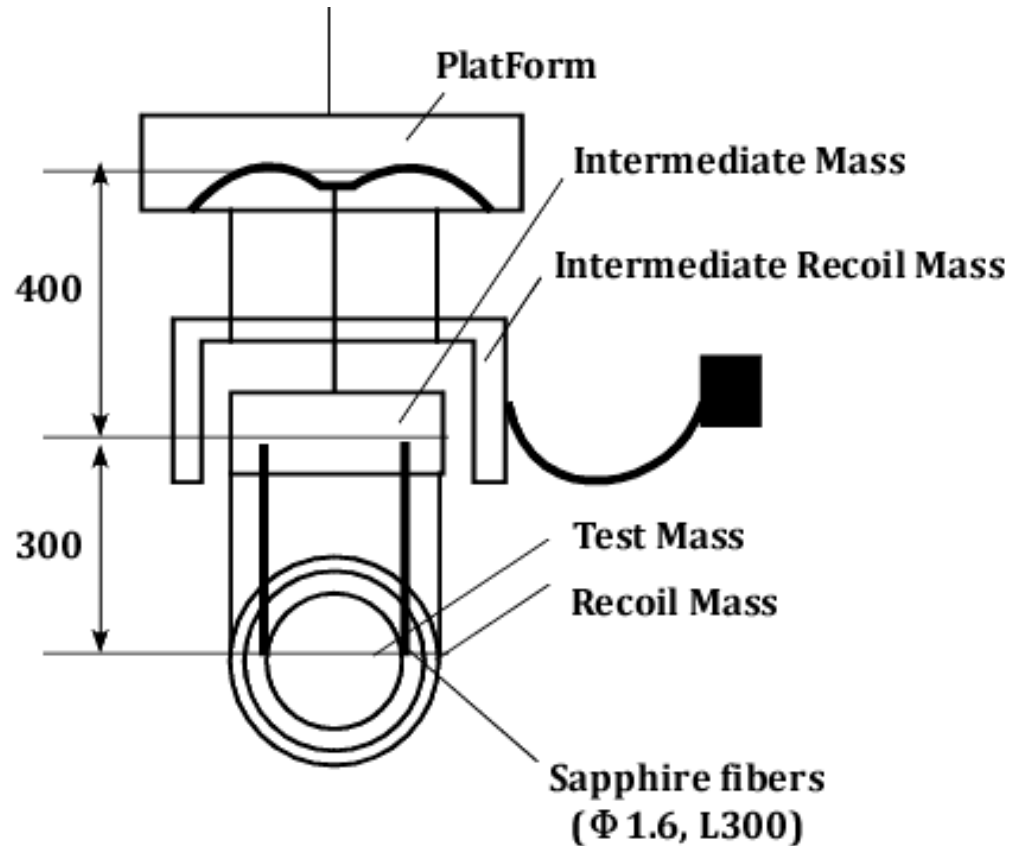

Heat Flow in Steady State

- Pure aluminum (5N) heat links are used for heat conduction.

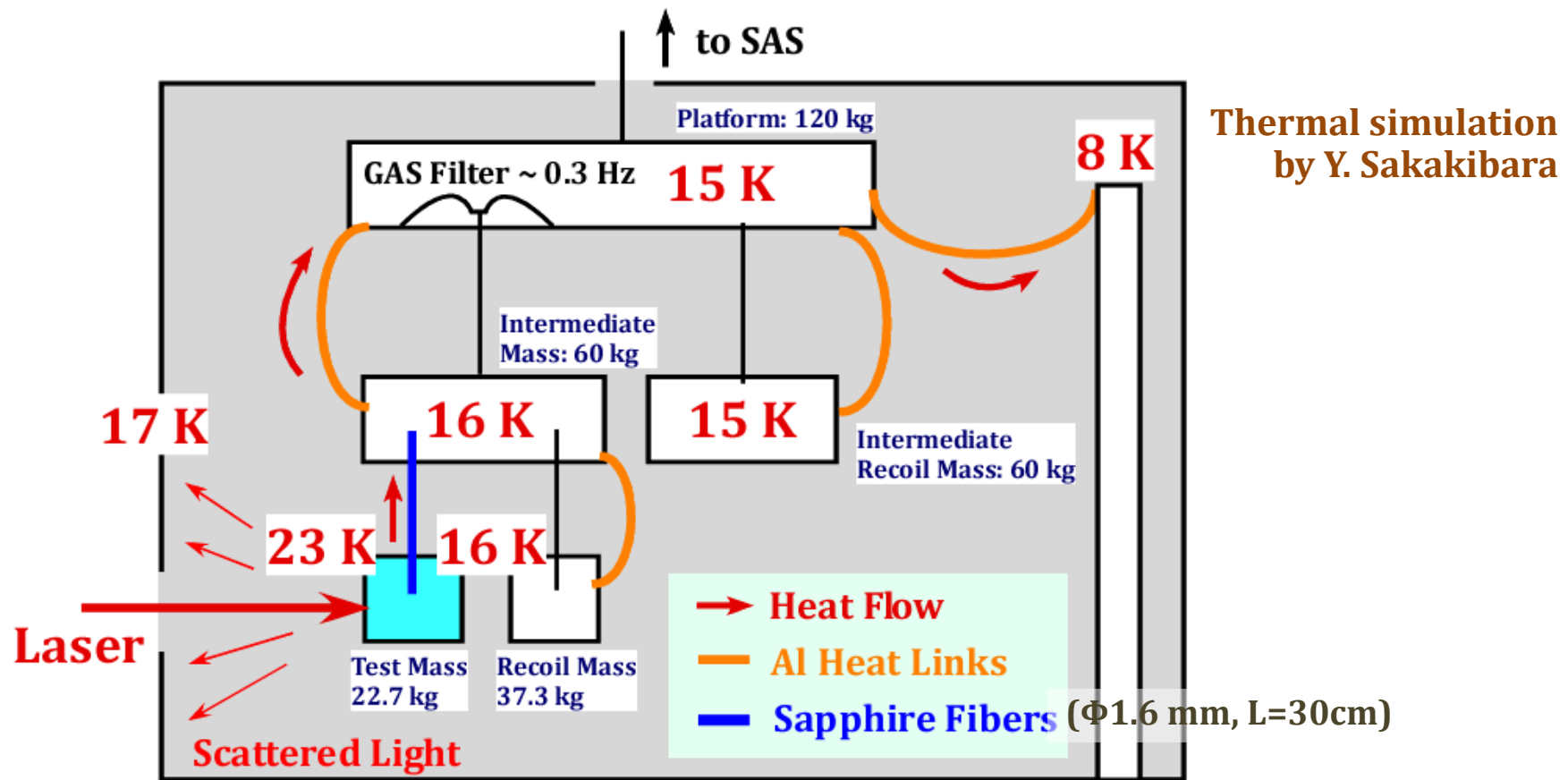

Problems of Cryogenic Suspension

- **Thick sapphire fibers have large stiffness in stretch and bending**
 - Vertical resonance at ~ 120 Hz appears in thermal noise spectrum.
 - Difficulty in balancing the tension due to small stretching length of fibers ($\sim 20 \mu\text{m}$)
 - Effective flexure point is 5 cm away from suspension point due to large stiffness of bending
- **Large vibration is transmitted through heat links.**
- **Cryogenic compatible displacement sensors, actuators (motors)**
- **How to compensate temperature drift of the spring?**
- **Material of wires, springs, masses**

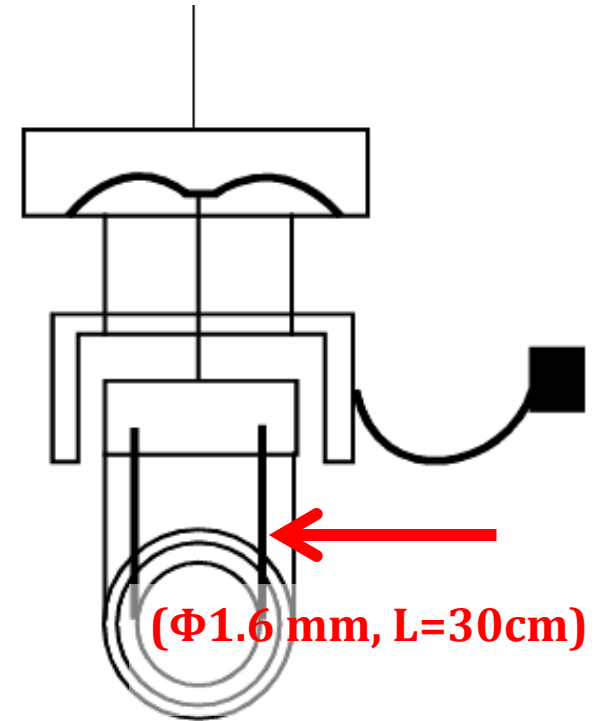

Suspension Thermal Noise

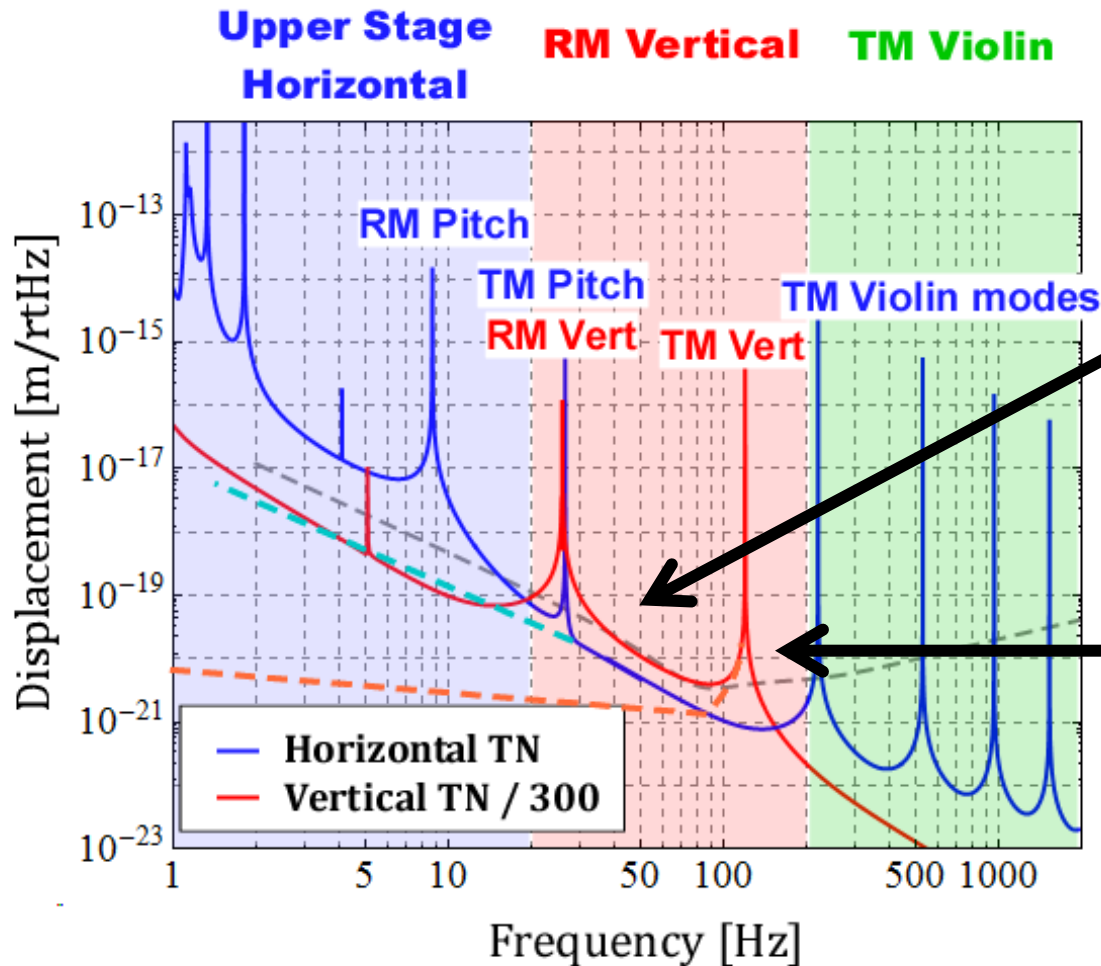

Thermal fluctuation at RM & IM transmit directly to the mirror

Huge peak at most sensitive frequency!!

Vibration via Heat Links

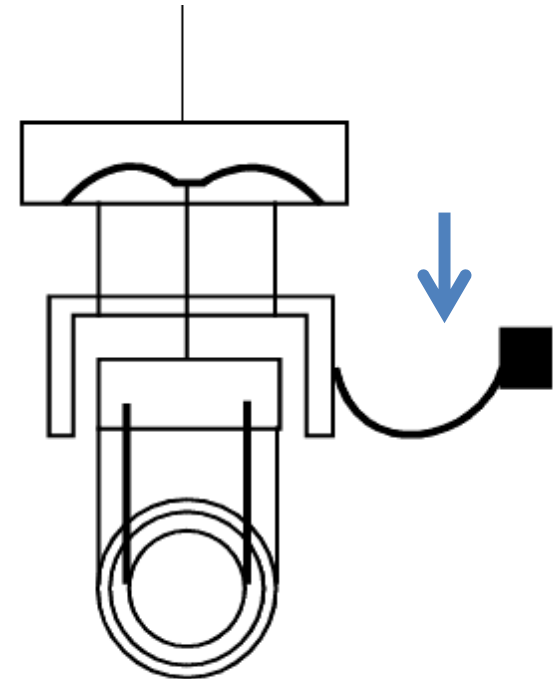
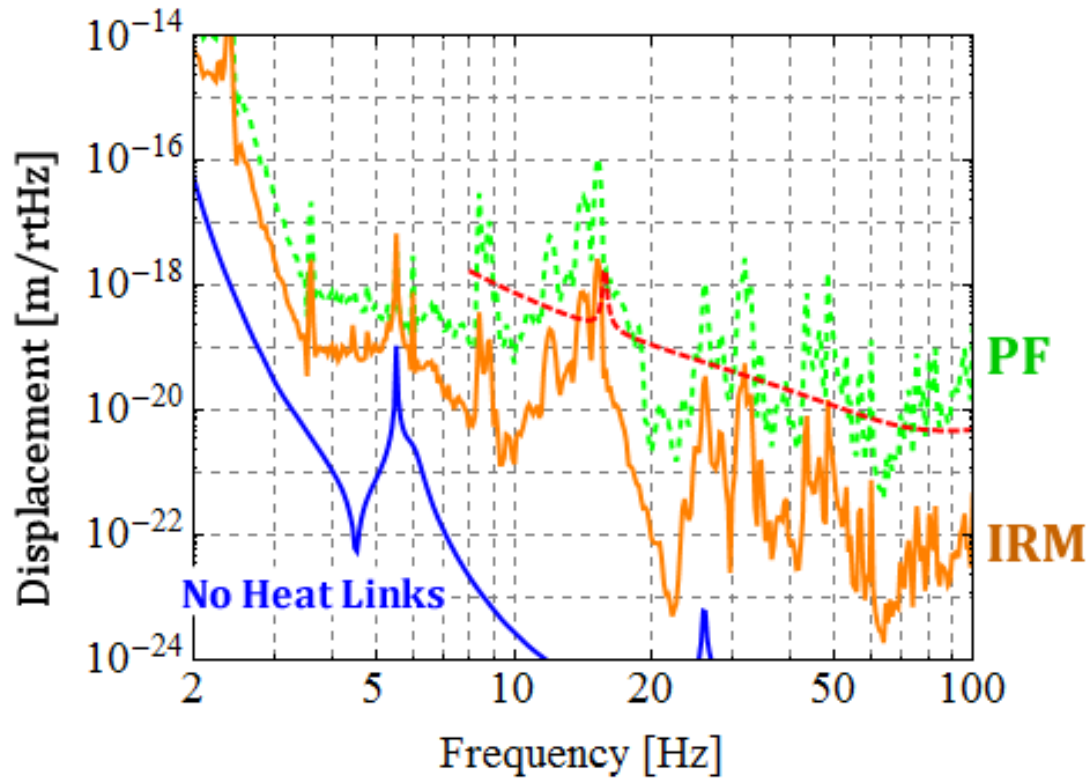

T. Sekiguchi, GWADW 2012

Bending point

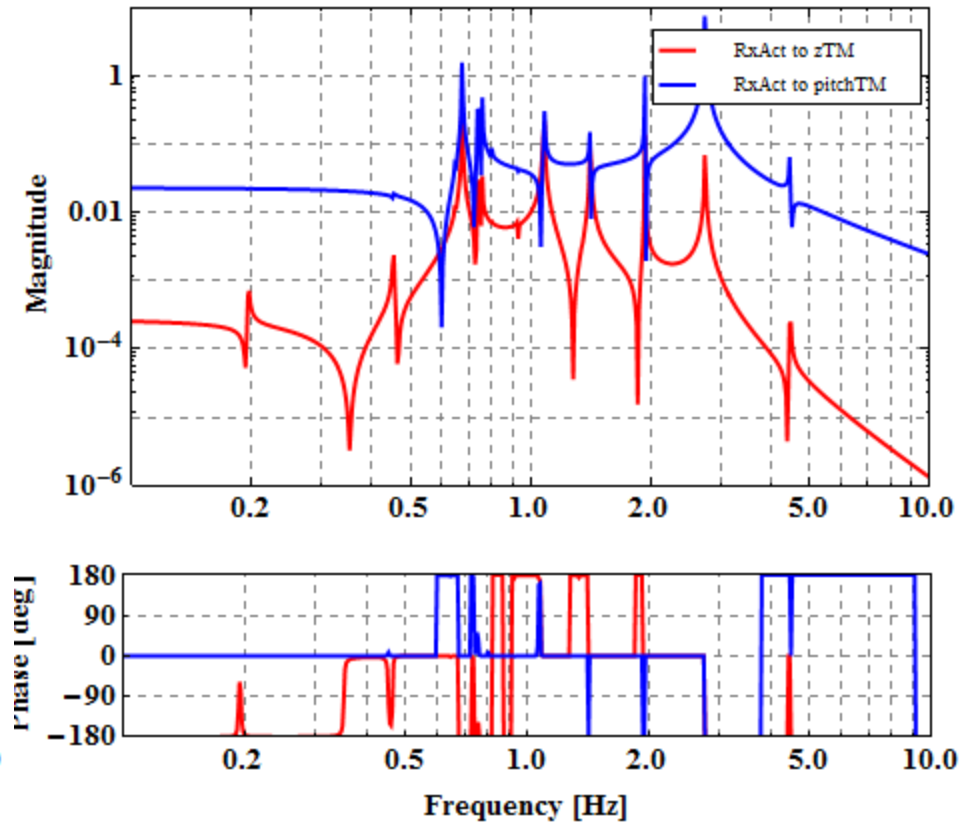
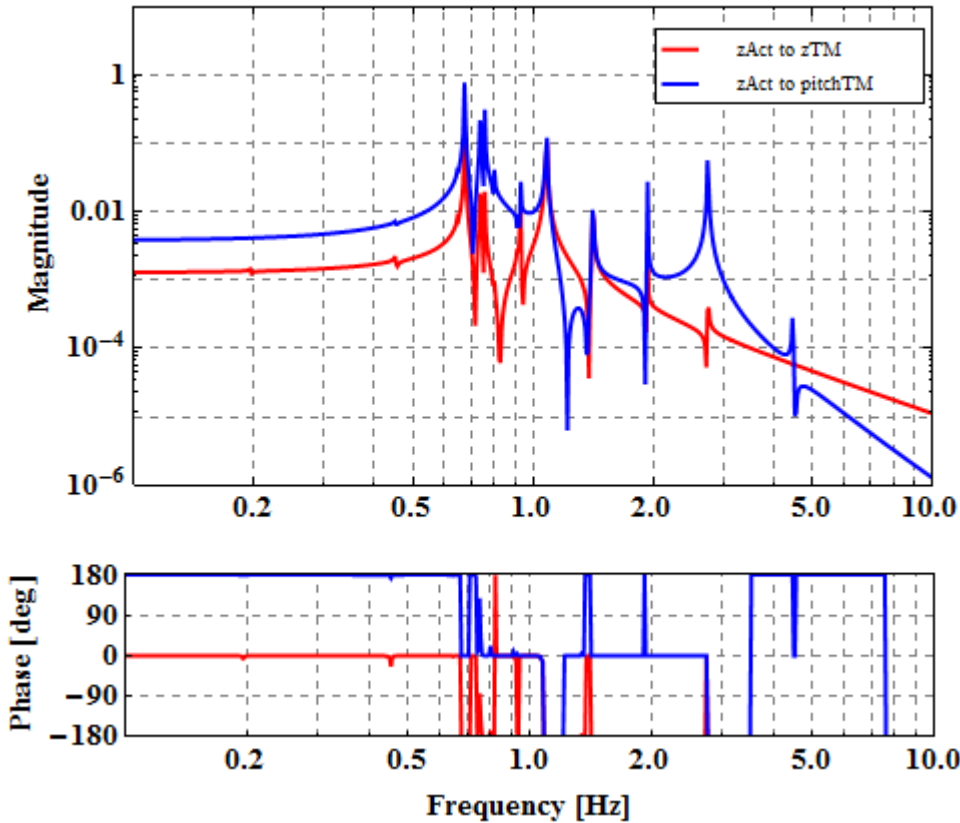

R&D

- Sapphire cantilever springs to mitigate vertical stiffness of sapphire suspension
- **Further attenuation of heat link vibration**
- **Improving suspension thermal noise**
- **Establishing control scheme**
- ...
- Cryogenic OSEMs: test of PD & LED
- Spring material for cryogenic suspension (CuBe)
- Stepper motors for cryogenic use
- ...

Modeling of SAS

SUMCON in *Mathematica*
spension odel structor



- 3-D Rigid body simulation
- Rigid body + elastic elements (wires and springs)
- Frequency domain simulation
- Structure damping loss → estimate thermal noise

Modeling Tools

SUMCON in *Mathematica*
spension odel structor



SUMCON Version:1.2

SUMCON in *Mathematica*
spension odel structor

SUMCON Version:1.2
About SUMCON Version Info Refresh

New Model Load Model Save Model TypeAinv#Blike_131203_HLcalc_addfiltering2Hz.m

Model Construction Calculation Result Export Model

Model Basic Information

Degrees of Freedom:
69 State Variables
12 Input Variables
11 Float Variables

Ground Position:
xg → 0 yg → 0 zg → 0 pitchg → 0 yawg → 0 rollg → 0
xCB → 0.5 yCB → -12.081 zCB → 0 pitchCB → 0 yawCB → 0 rollCB → 0

Equilibrium Point:

xF0 → 0	zF0 → 0	yawF0 → 0	xMD → 0	yMD → -1.31	zMD → 0
pitchMD → 0	yawMD → 0	rollMD → 0	xF1 → 0	yF1 → -1.656	zF1 → 0
pitchF1 → 0	yawF1 → 0	rollF1 → 0	xF2 → 0	yF2 → -3.937	zF2 → 0
pitchF2 → 0	yawF2 → 0	rollF2 → 0	xF3 → 0	yF3 → -6.218	zF3 → 0
pitchF3 → 0	yawF3 → 0	rollF3 → 0	xF4 → 0	yF4 → -8.601	zF4 → 0
pitchF4 → 0	yawF4 → 0	rollF4 → 0	xPF → 0	yPF → -11.996	zPF → 0
pitchPF → 0	yawPF → 0	rollPF → 0	xIR → 0	yIR → -12.396	zIR → 0
pitchIR → 0	yawIR → 0	rollIR → 0	xIM → 0	yIM → -12.397	zIM → 0
pitchIM → 0	yawIM → 0	rollIM → 0	xRM → 0	yRM → -12.697	zRM → 0
pitchRM → 0	yawRM → 0	rollRM → 0	xTM → 0	yTM → -12.697	zTM → 0
pitchTM → 0	yawTM → 0	rollTM → 0	xHP → 0.5	yHP → -12.386	zHP → 0

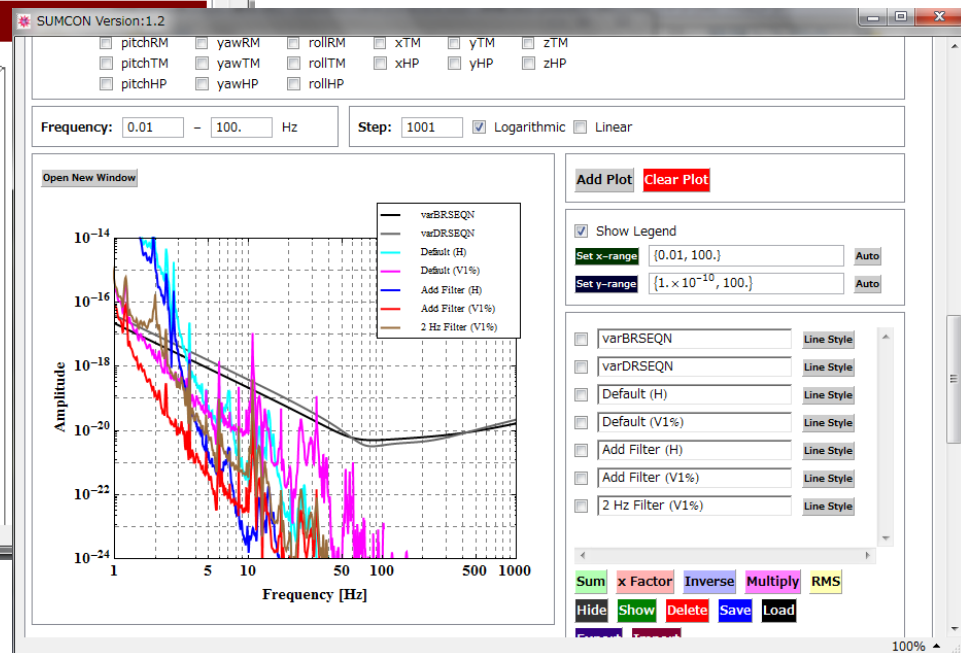

Modeling of Heat Links

- Transfer function of heat links is estimated by FEA (COMSOL)
- Modeled as a spring with frequency-dependent stiffness coefficient

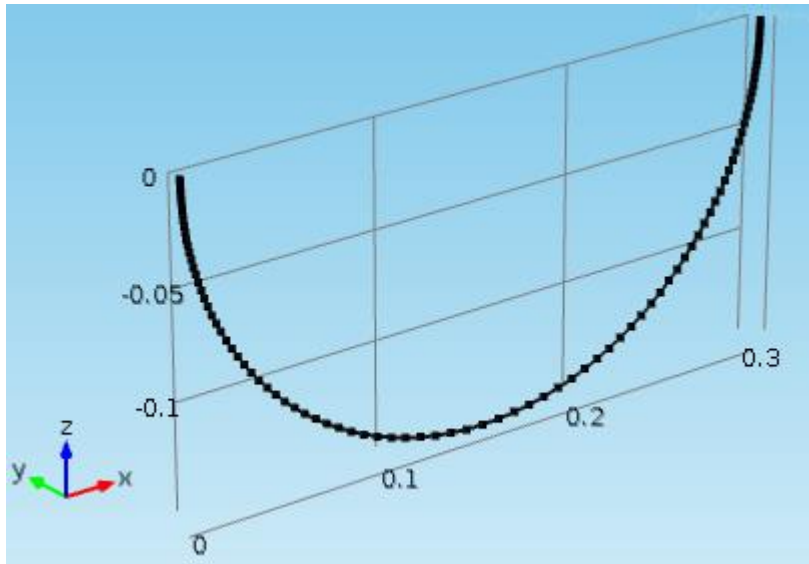

Simulated TF of an aluminum fiber:
Attached to a 50kg Mass

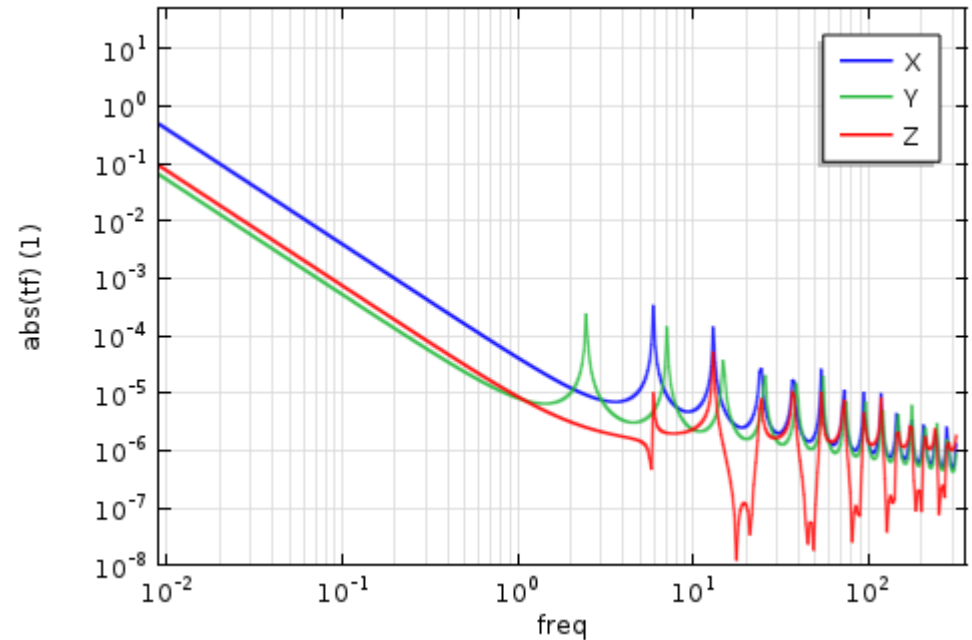

Suspension Thermal Noise

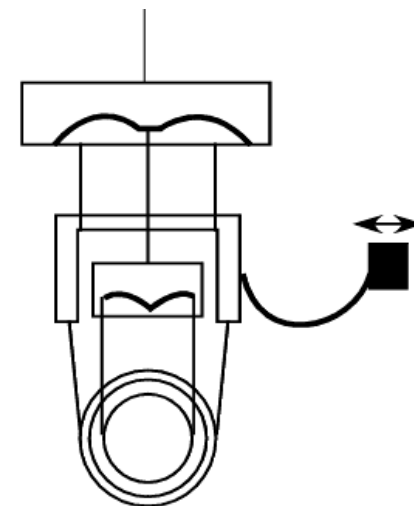
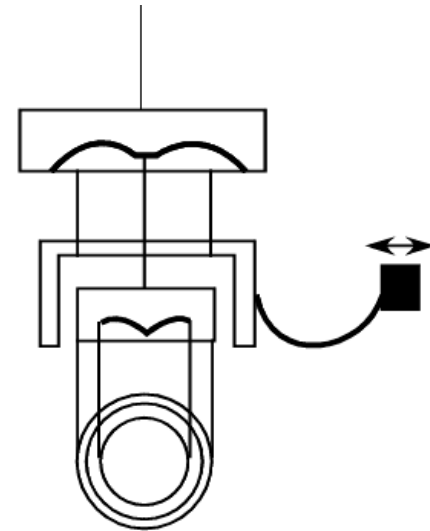
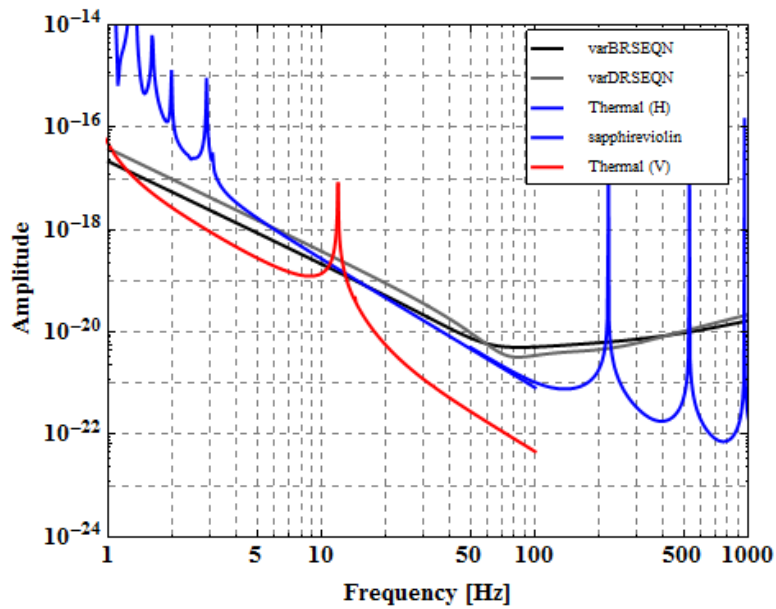
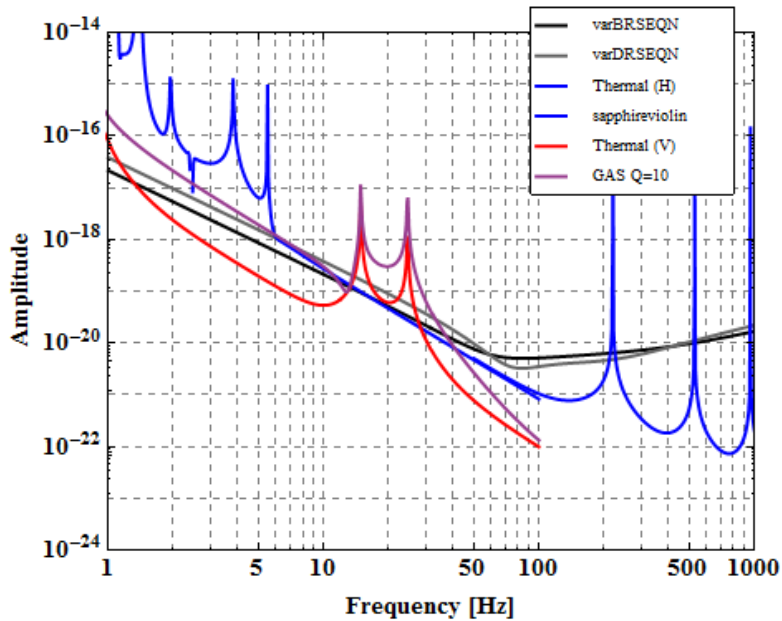

Control Models

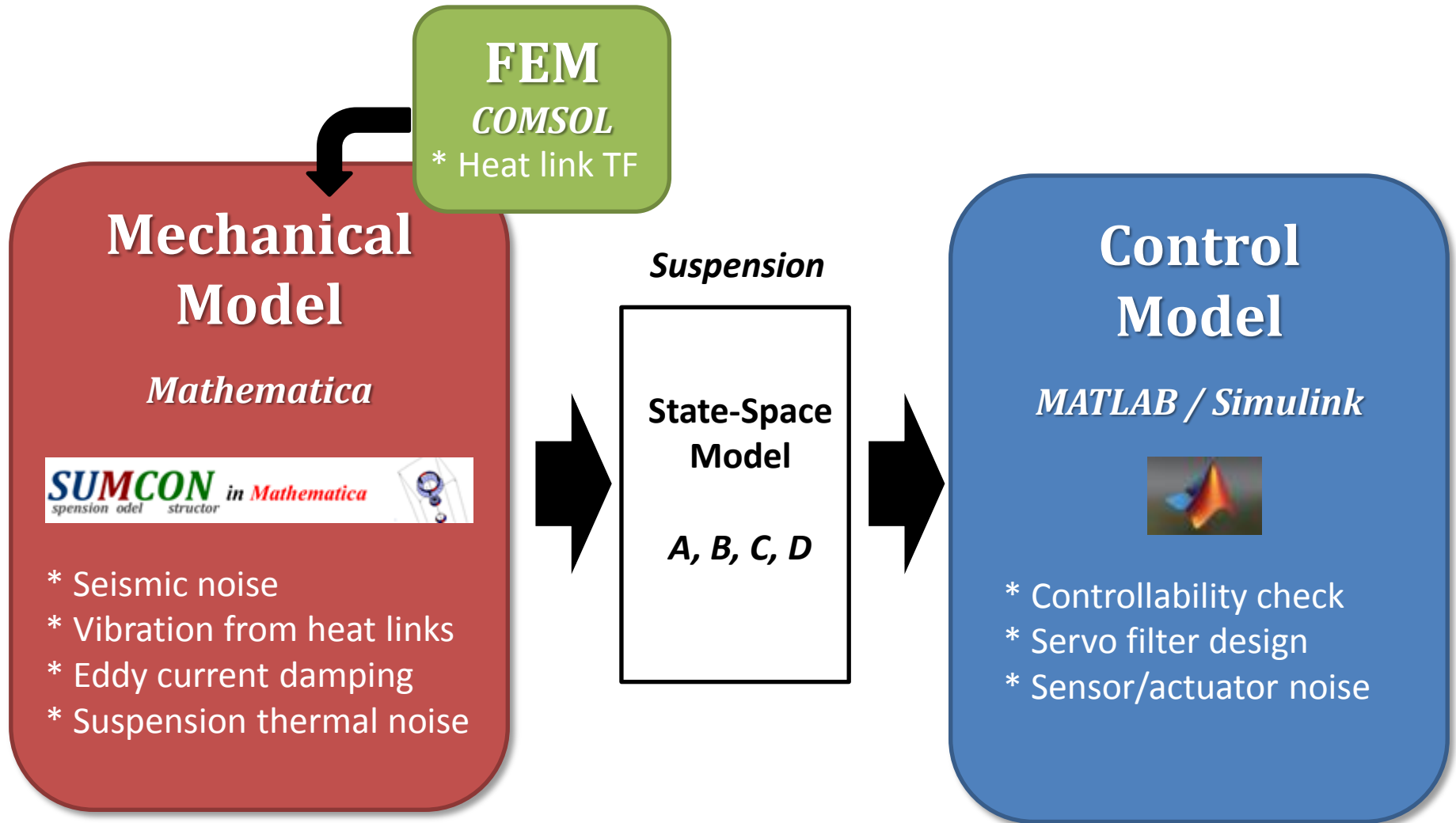

Control Model

MATALB/Simulink

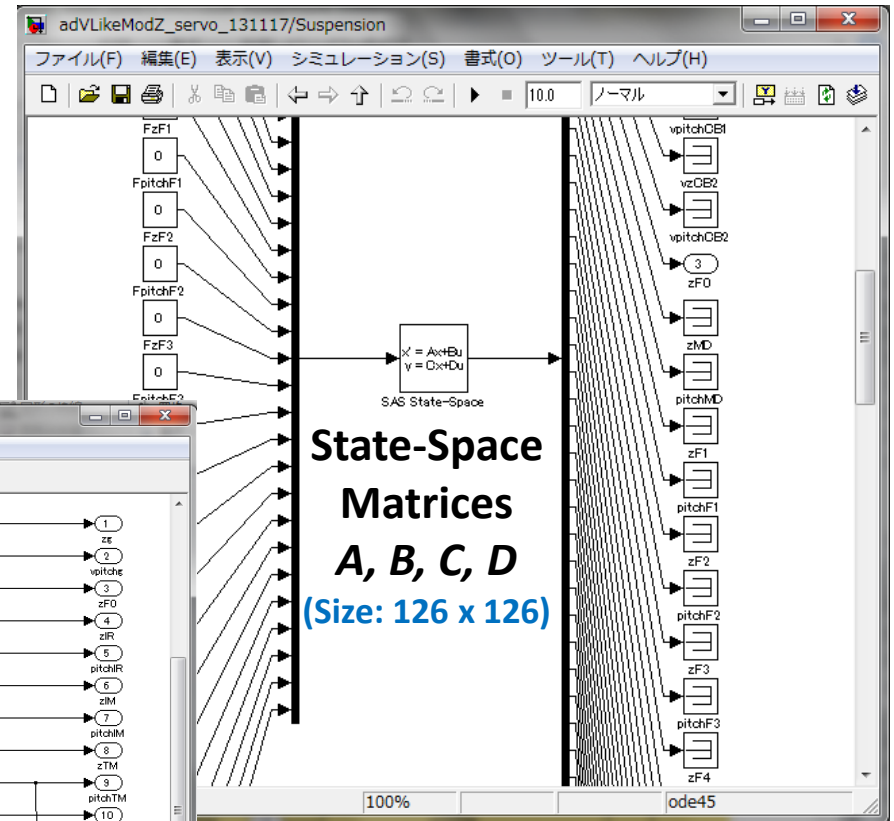
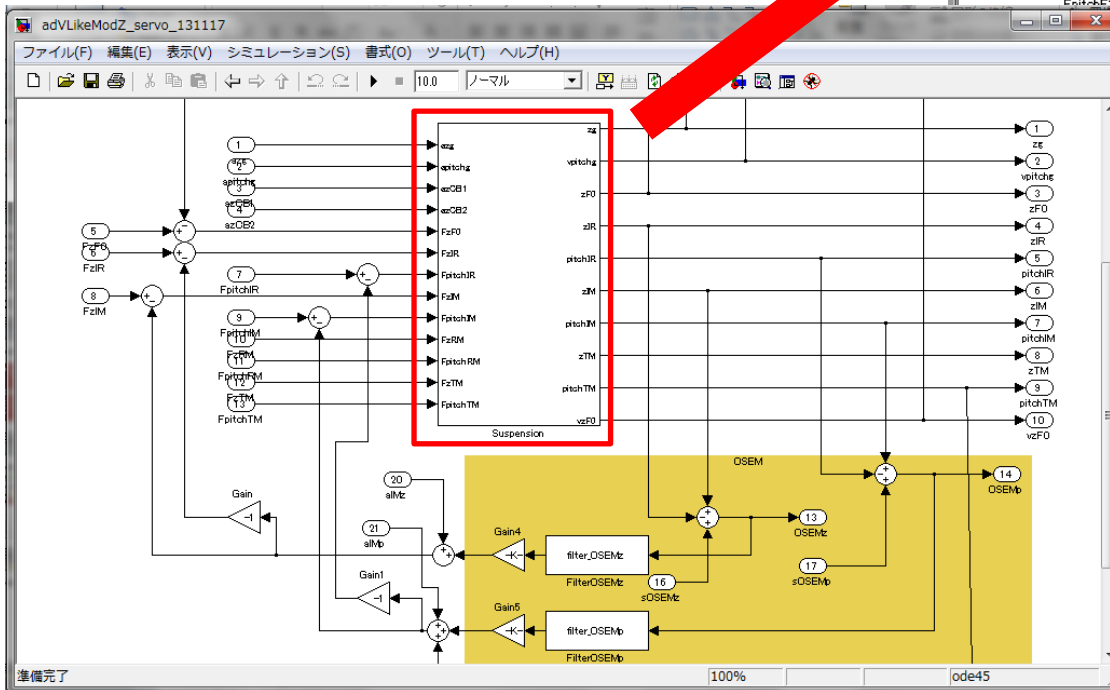

State-Space
Matrices
 A, B, C, D
(Size: 126 x 126)

Modeling and simulation are on going...

Modeling Tools

Simple viscous damping..

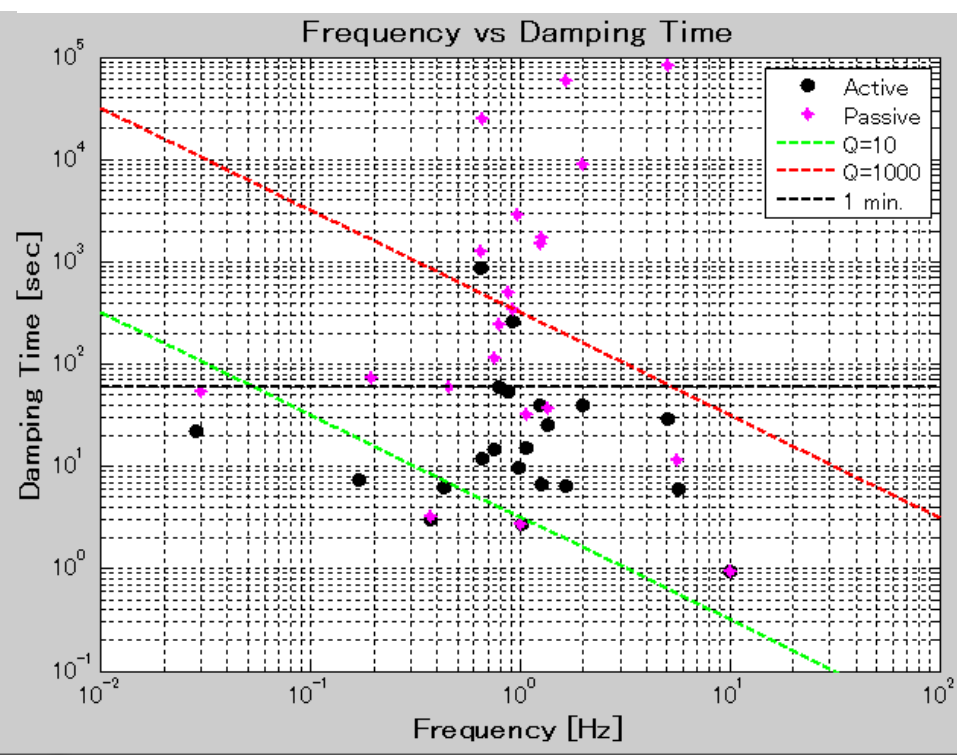
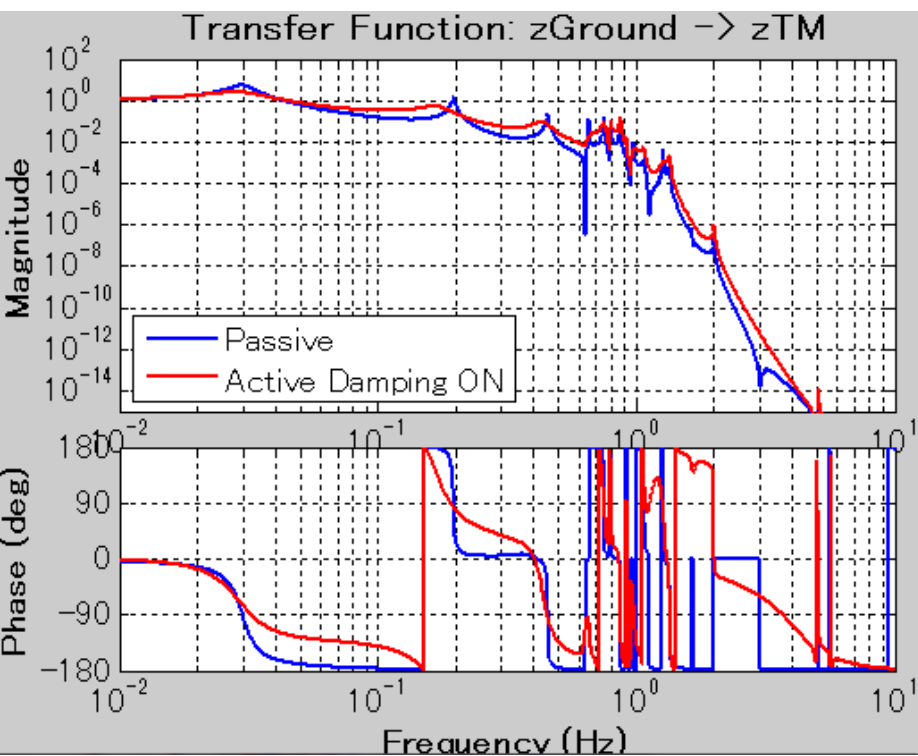

Modeling and simulation are on going...

Strategy

- Control strategy
 - Control before locking
 - Control after locking
- What is the requirement for each case?
 - Damping time
 - RMS displacement / velocity
 - (Sensor / actuator) noise

END

Appendix

Overview

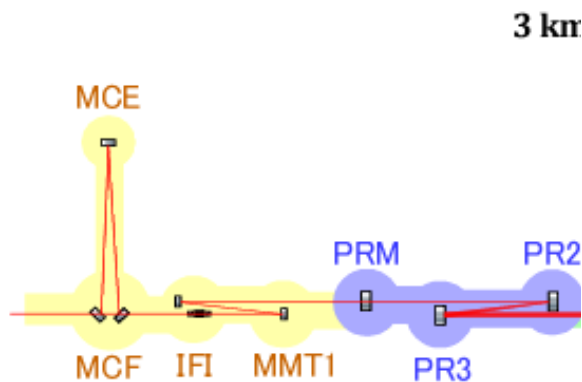

3 km

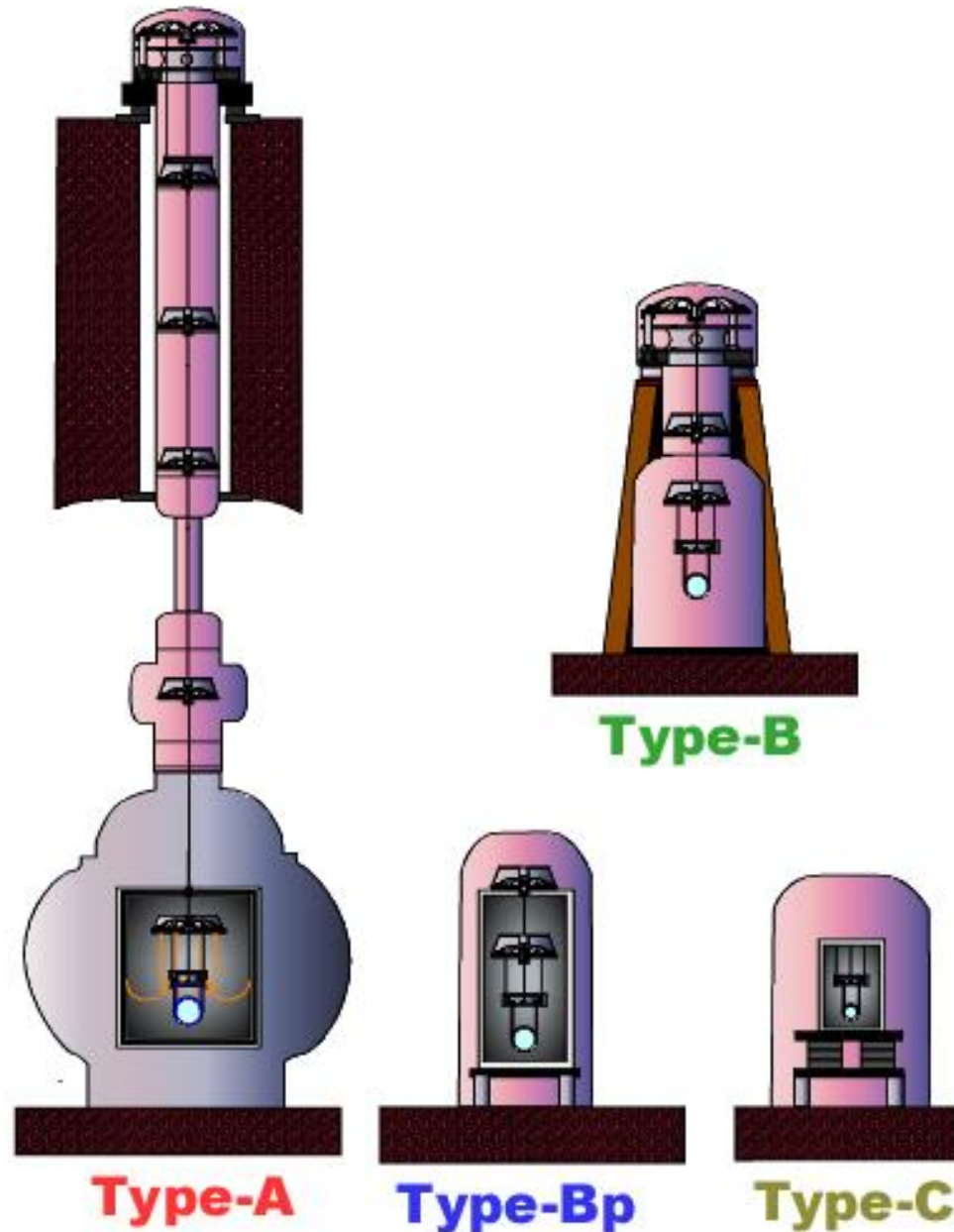

bKAGRA Optical Layout and Disposition of Vibration Isolation Systems

Overview

- **Type-A:** Large seismic attenuation system (SAS) + **cryogenic** suspension, utilizing two-layer tunnels (~13 m)
- **Type-B:** Smaller version of SAS with room temperature payload (~3 m)
- **Type-C:** Stack + double pendulum, Design identical with TAMA suspension

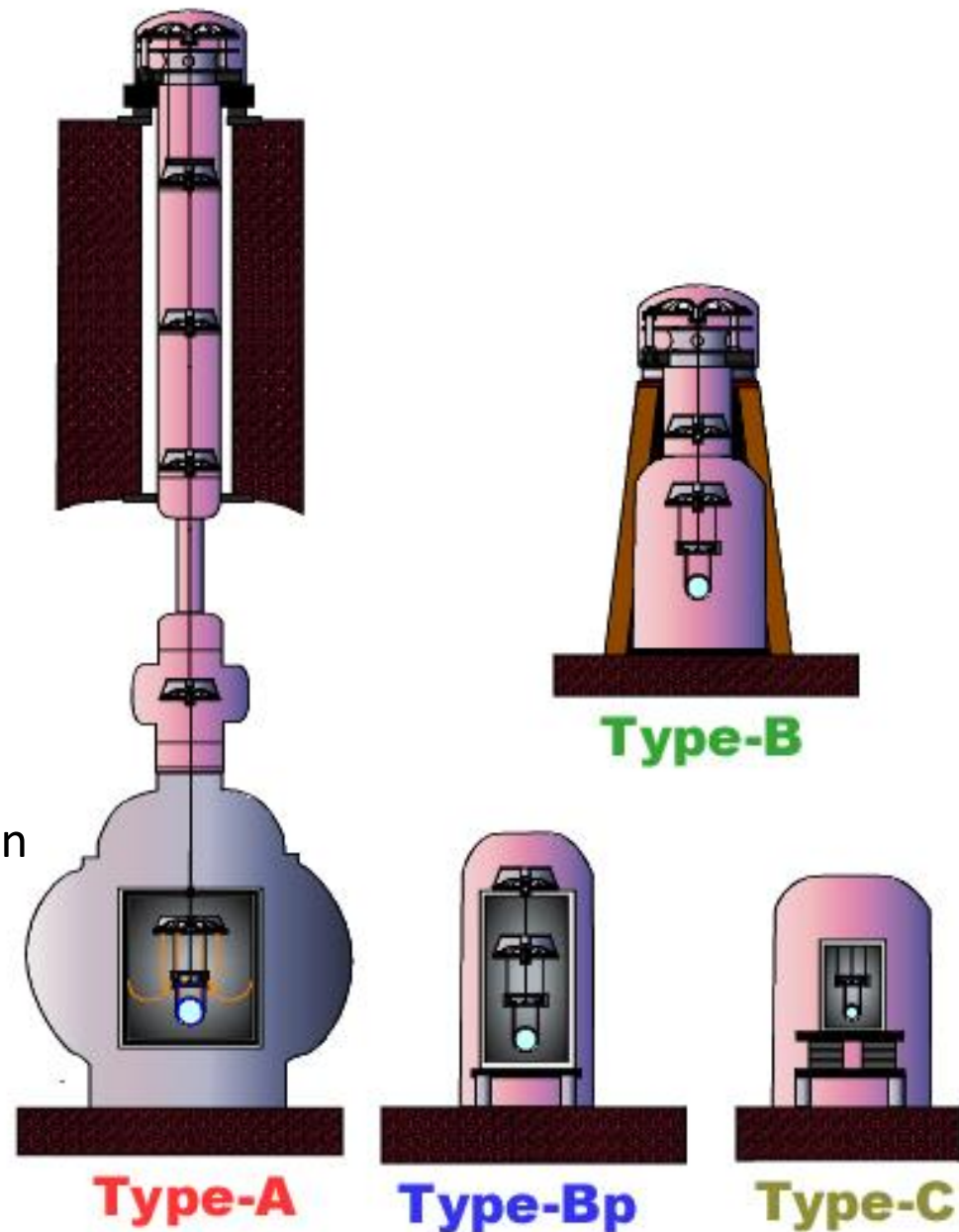

Passive Attenuation Performance

Type-B:

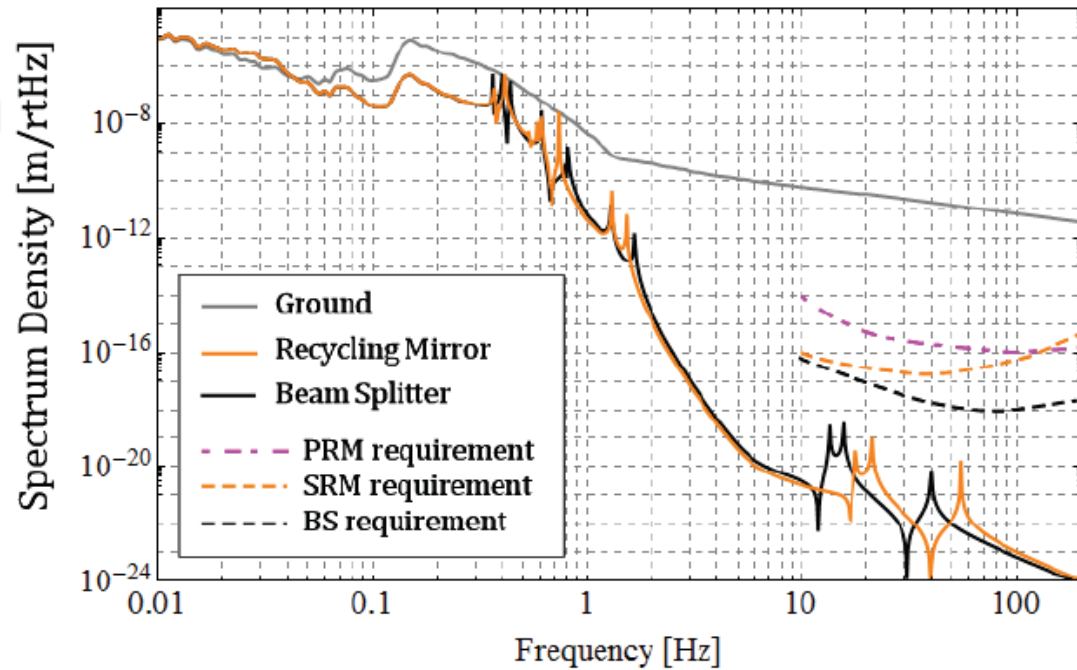

Type-A:

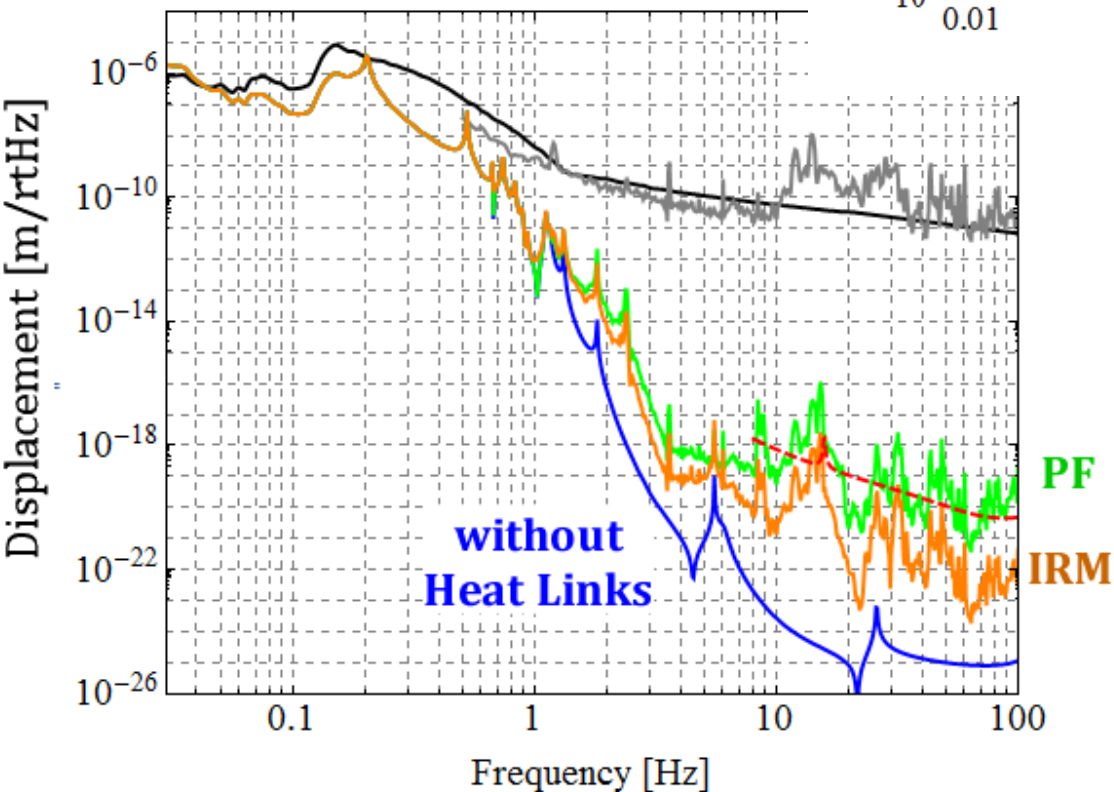

Function of Pre-isolator (1)

- Translation mode of the IP stage can be tuned at 30-50 mHz.
- It attenuates micro-seismic peak (at 0.2 Hz) by a factor of ~ 10 .

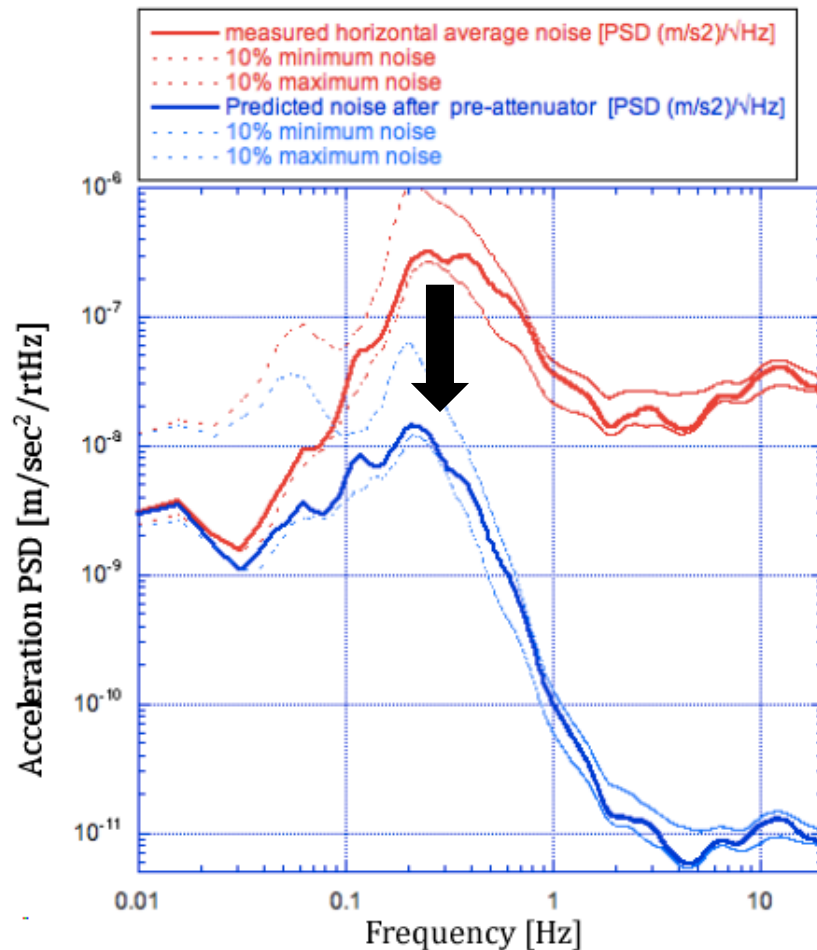

Function of Pre-isolator (2)

- Mirror DC position control
- Active damping of pendulum modes



Replaced by L-4C
Geophone

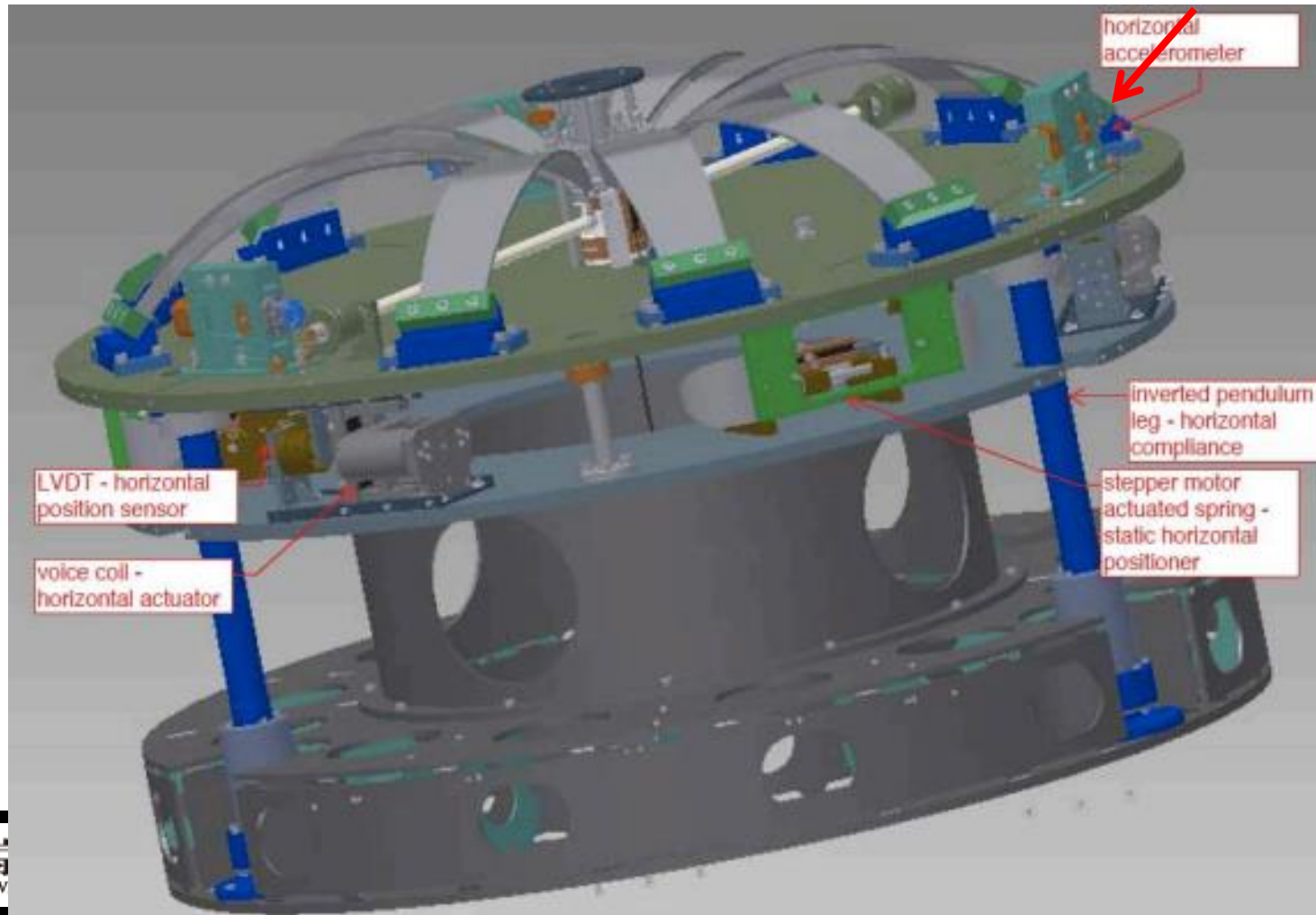

Active Control of IP Stage

- Simulation

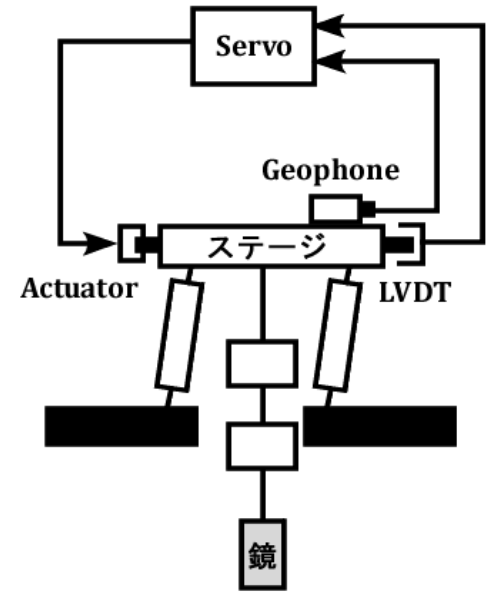

Servo filter design

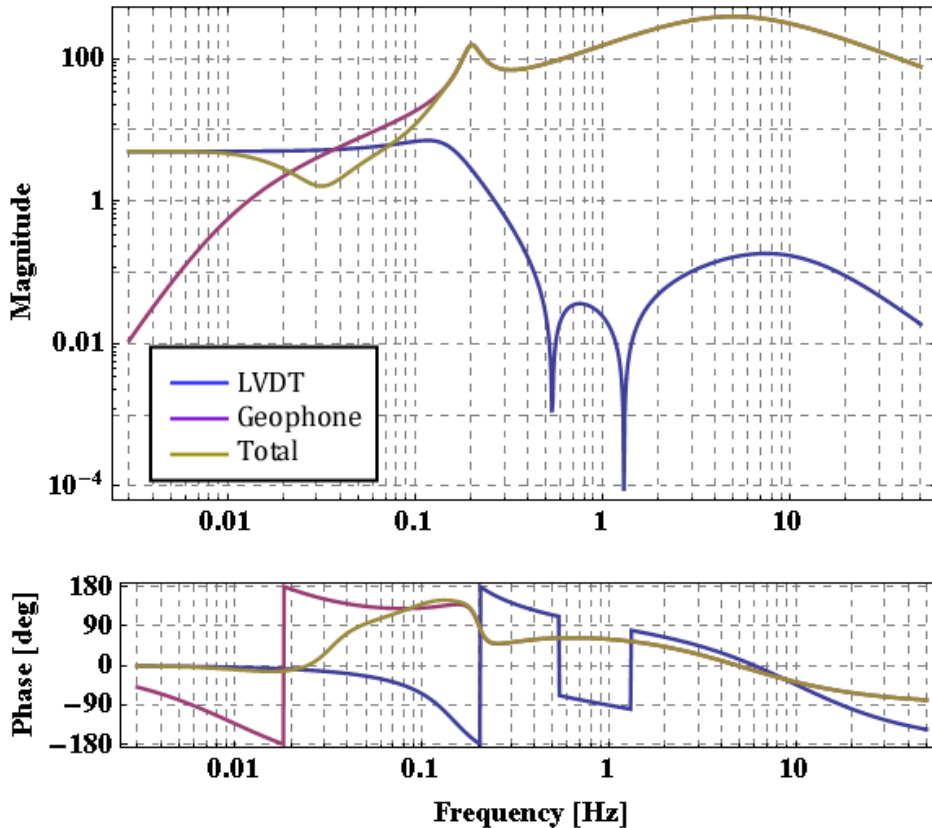

Simulated TFs

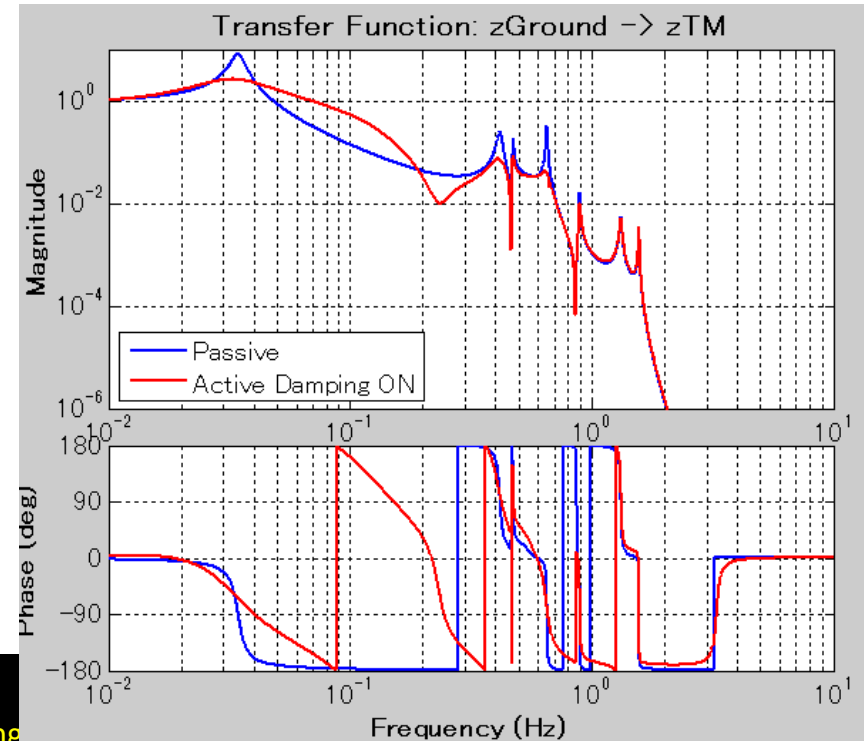

Pre-isolator Prototype Test

- IP stage (tuned at 80 mHz) is controlled by digital control system from LIGO
- Air disturbance and low frequency noise of geophone are the main problems.
- Test in vacuum will start from 2014.2.

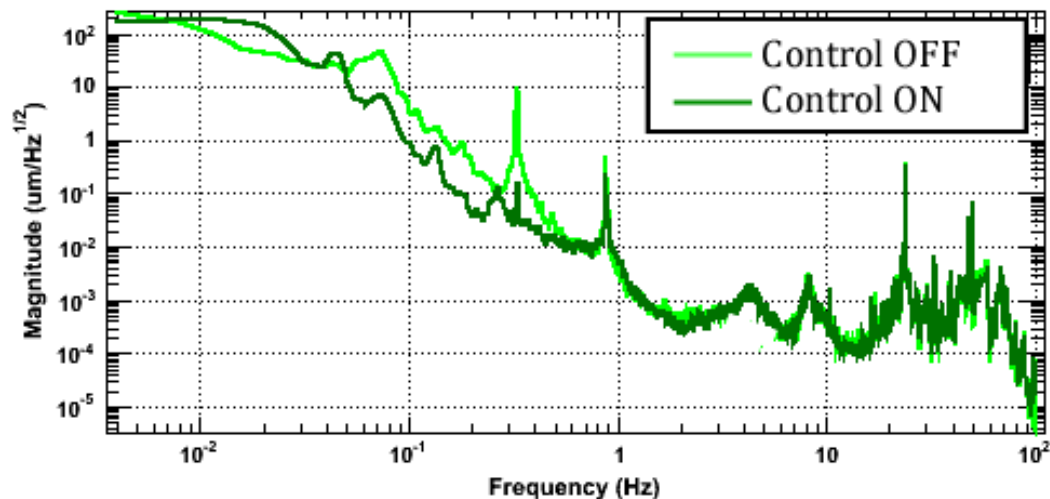

Standard GAS Filter Test

Prototype test at NIKHEF:

- ✓ Tuning of resonant frequencies
- ✓ Measurement of mechanical transfer function

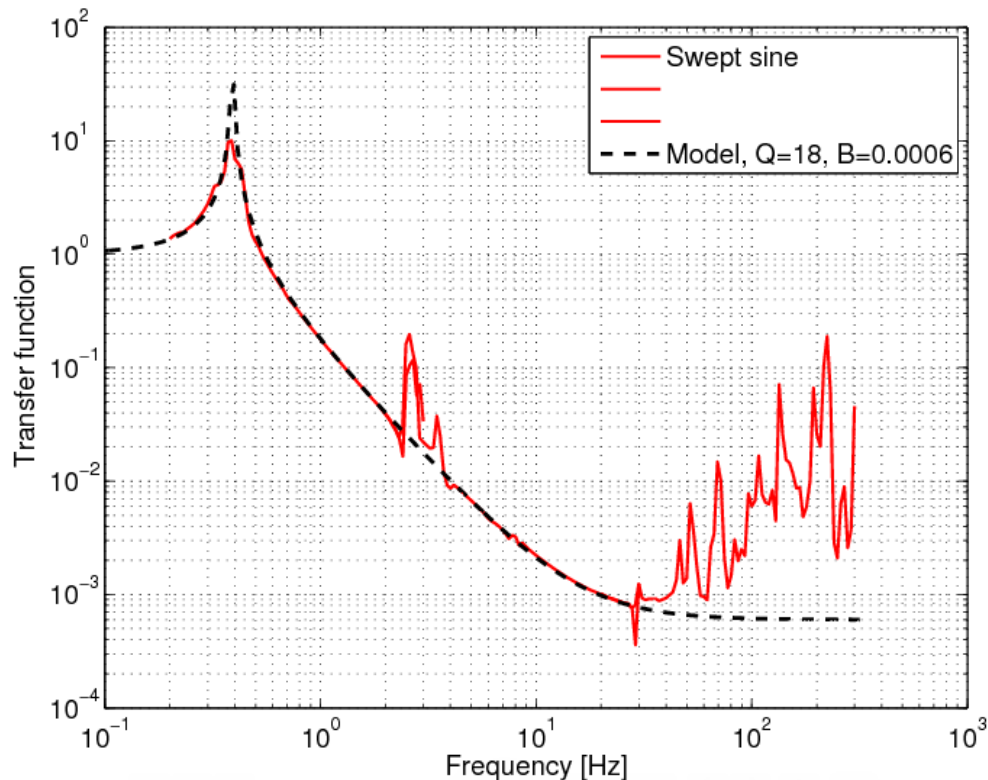
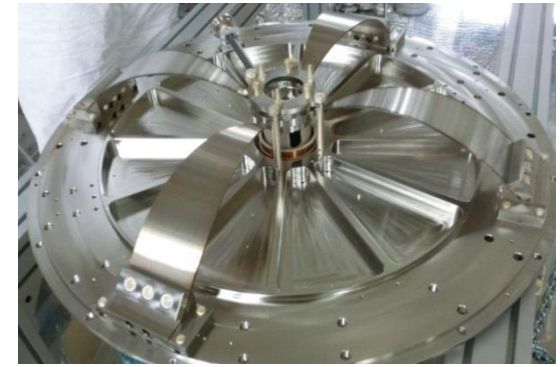

Torsion Mode of Suspension

- Large decay time of torsion modes of the attenuation chain was a big problem in TAMA-SAS and Virgo SA.

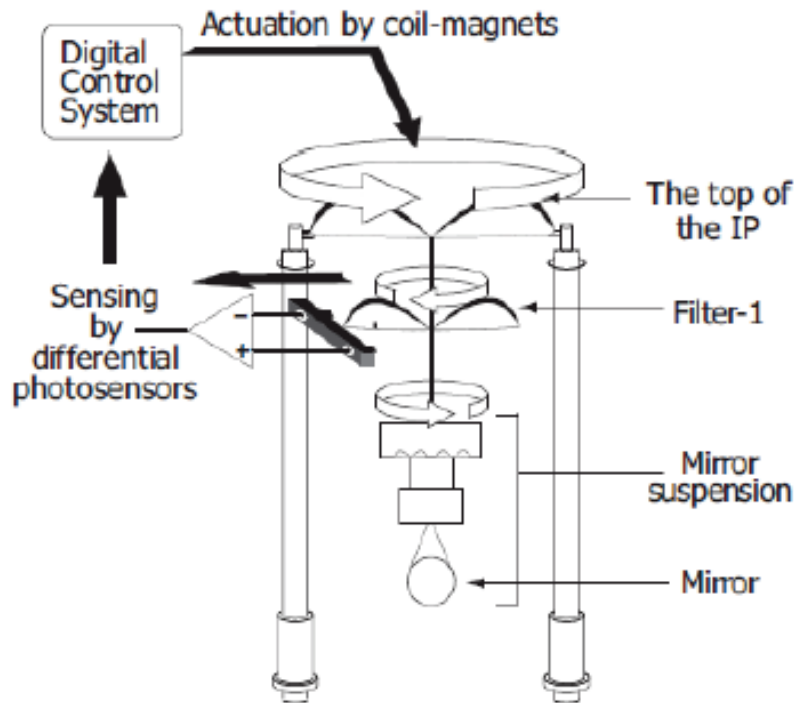

Active damping system is used in TAMA-SAS, but it is not usable for large excursion due to limited sensor range...

Torsion Mode Damping

- Passive damping system for KAGRA-SAS
- Tuning of wire thickness is required for effective damping
- Simulation has been done, but verification in experiment is not yet;

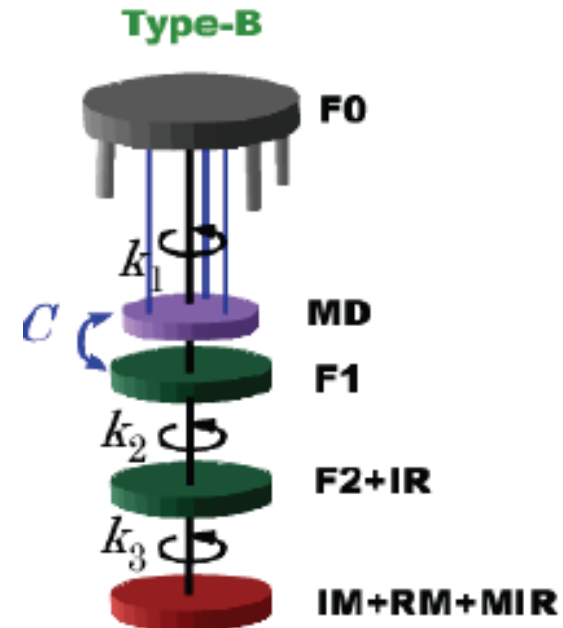
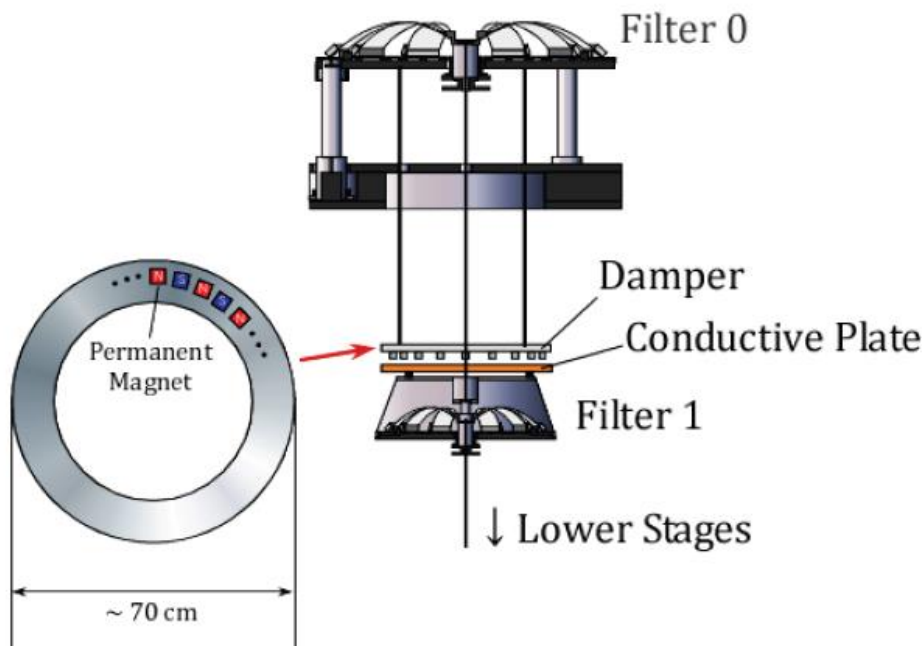

Torsion Mode Damping

- Simulation results

	D [mm]	L [m]	kt [Nm/rad]	I [kg m ²]	γ [kg m ² /sec]
Stage 1	2.3	1.28	0.16	7.3	3.0
Stage 2	2.0	0.51	0.21	6.8	-
Payload	1.0	0.58	0.012	0.42	-

Table 3: Parameters for Type-B1 SAS

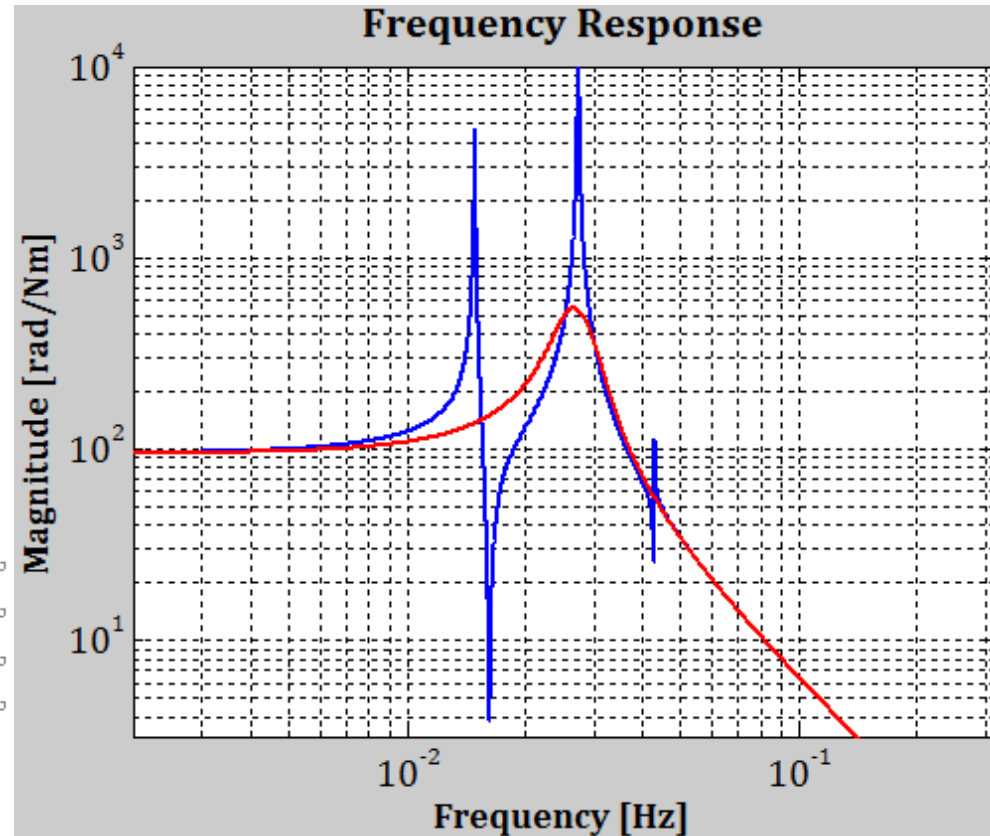

head to hook the wire



Payload (Mirror Suspension)

- Mirror is suspended by 2 loops of tungsten fibers from the intermediate mass (IM).
- IM is suspended by a single wire and its 6 DoFs motion is controlled by **OSEMs**.

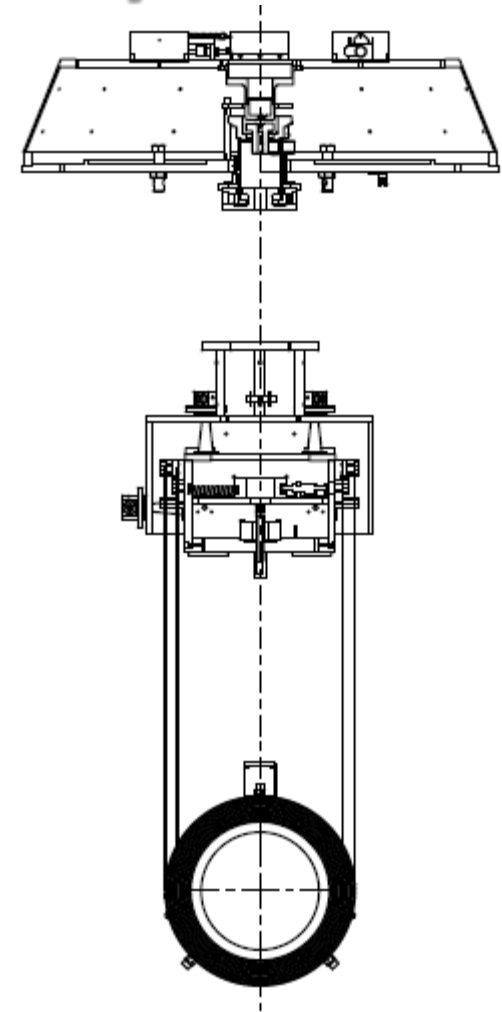
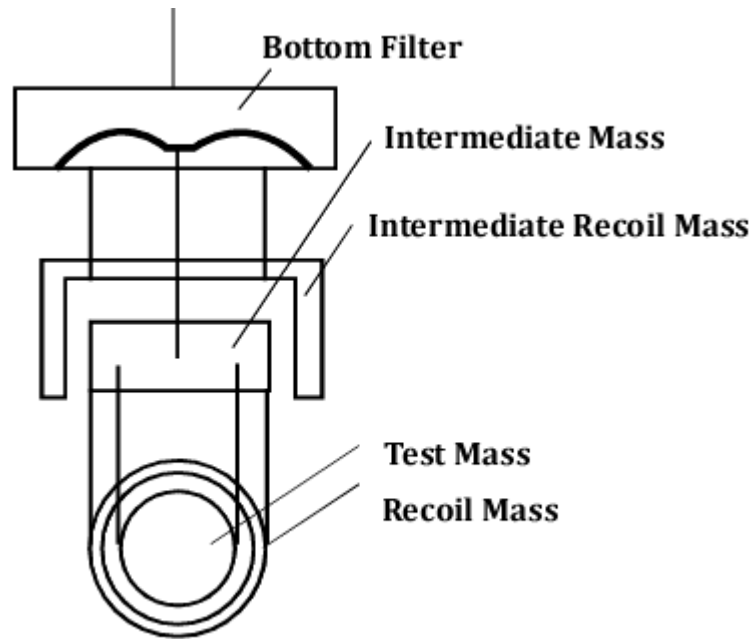

Test Mass & Recoil Mass

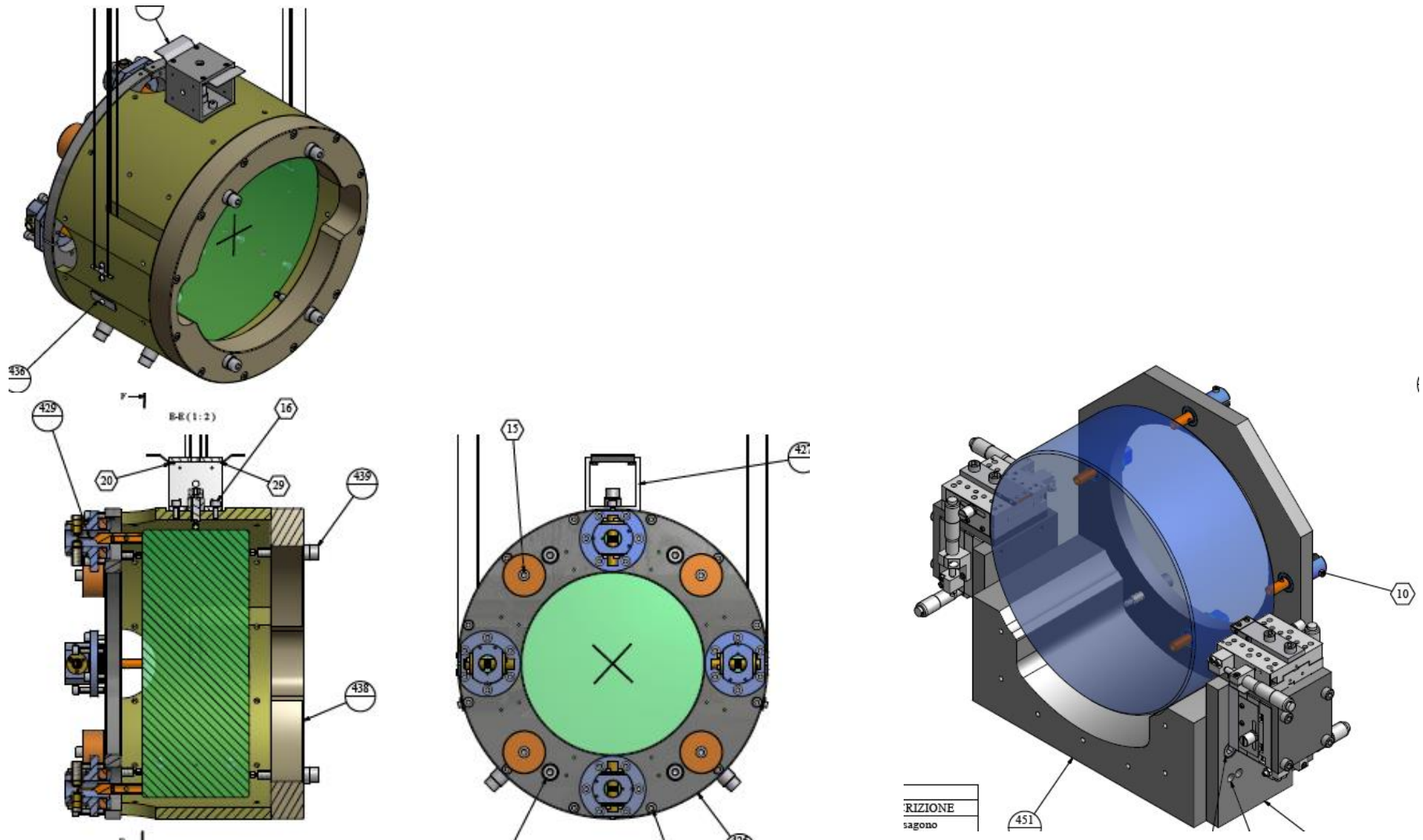

Intermediate Mass Structure

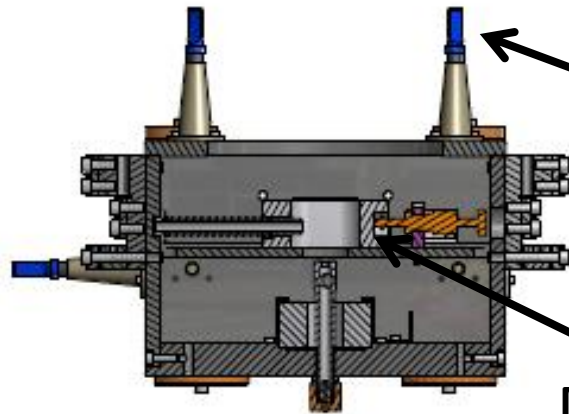

Flag for OSEM

Motorized counter-mass
For DC alignment

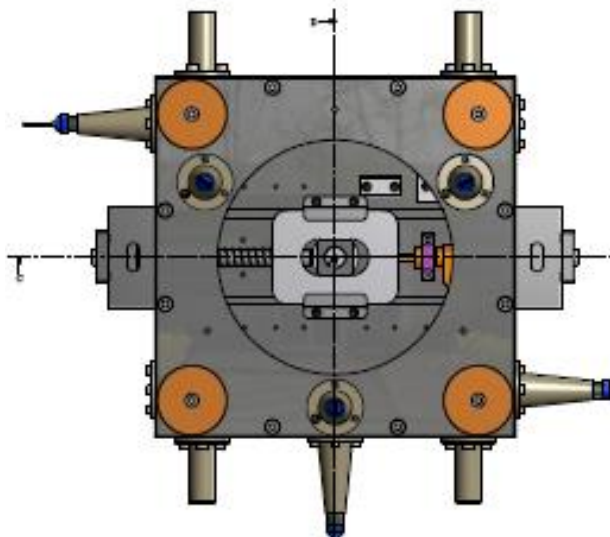
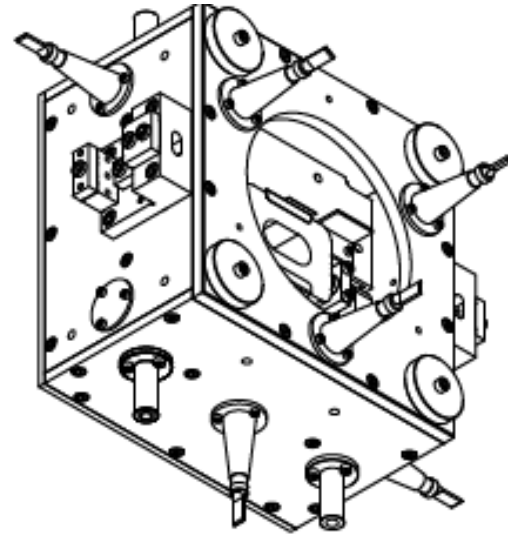

Wire clamp for TM & RM

OSEM

- Local sensor and actuator for the payload control.
- Improvement & test: Nicholas Lockerbie

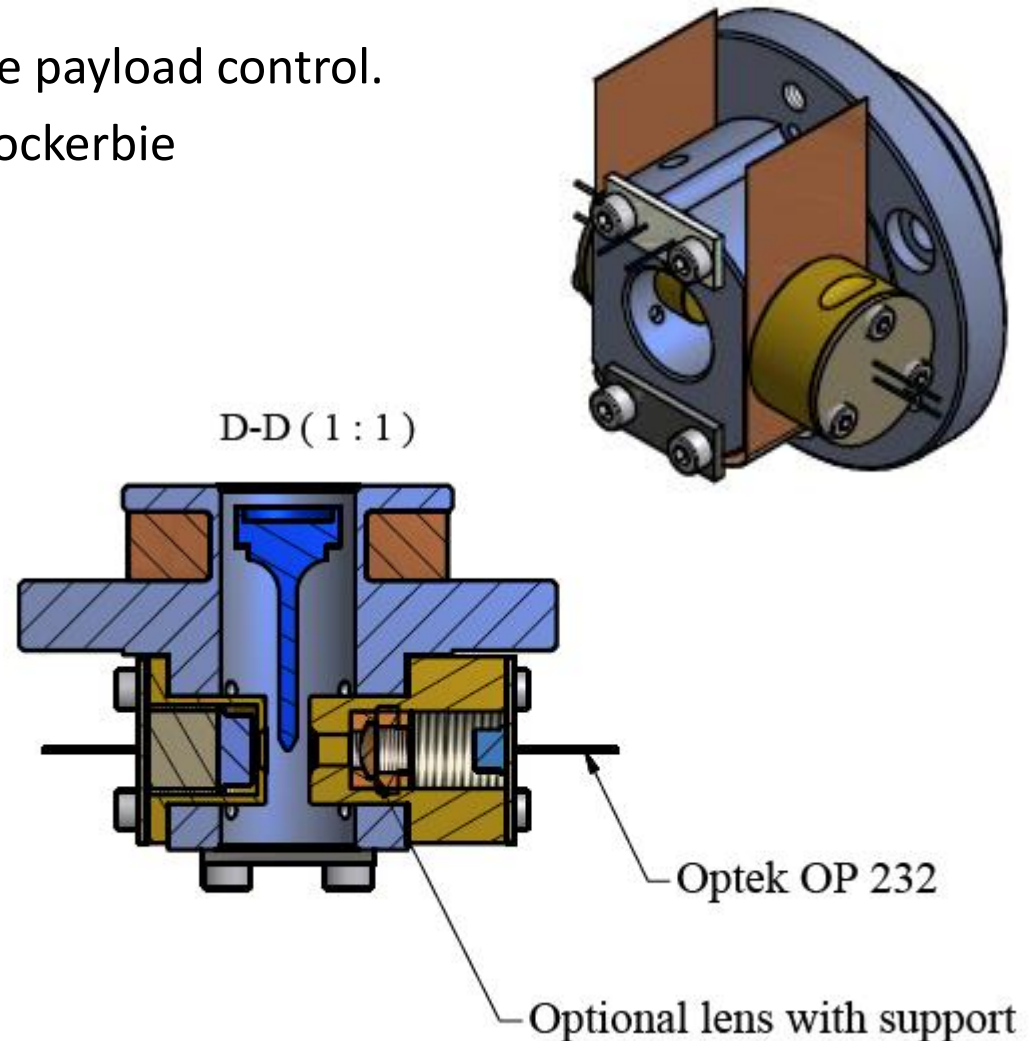

OSEM

- Circuit diagram designed by Nick.

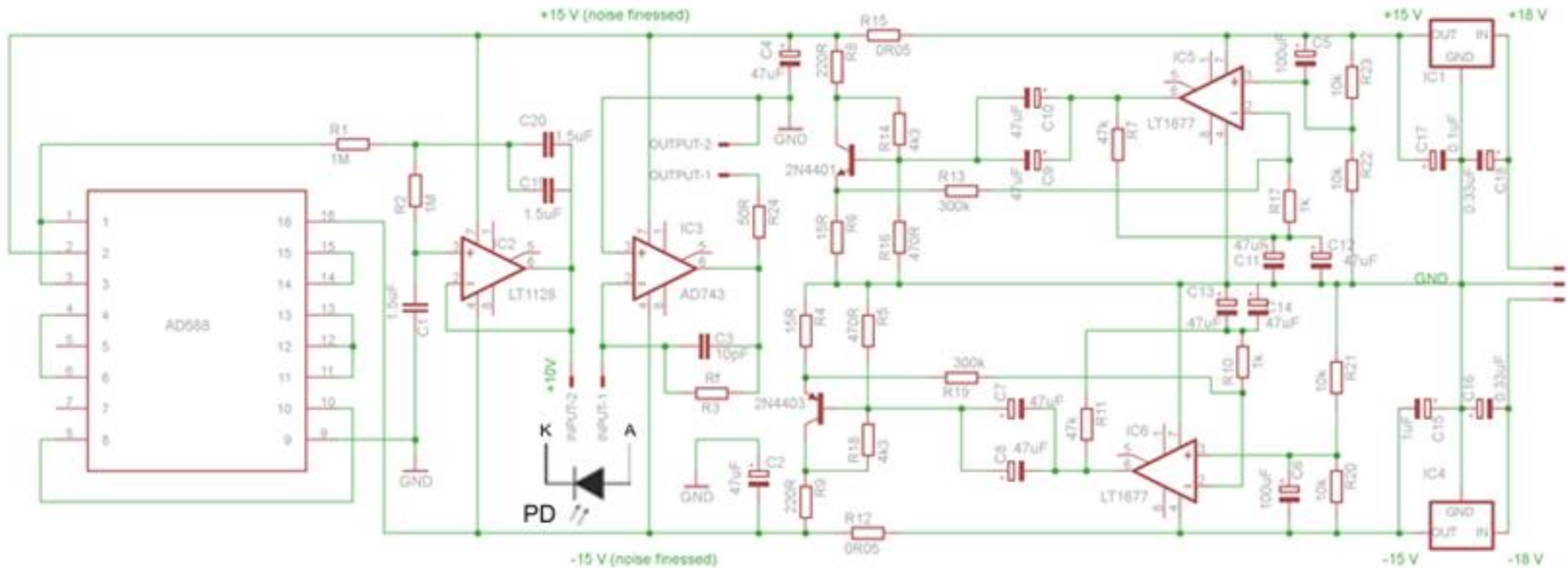
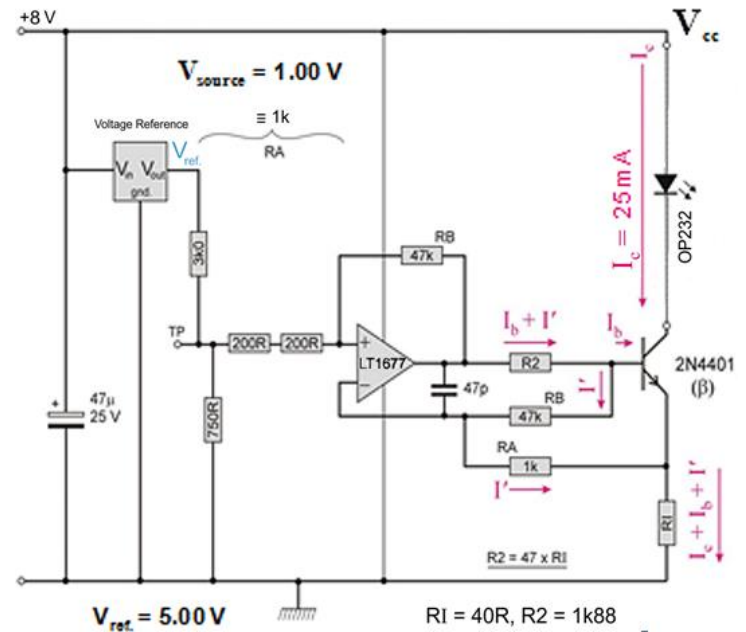

OSEM

- Sensitivity measurement by Nick

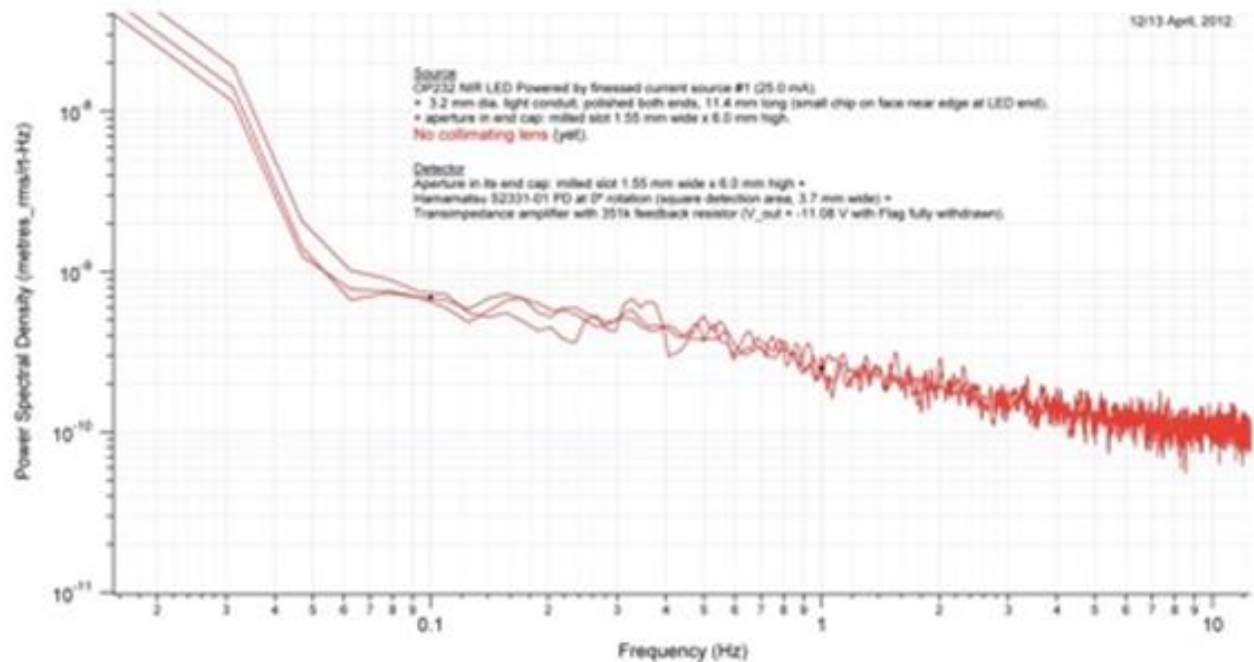
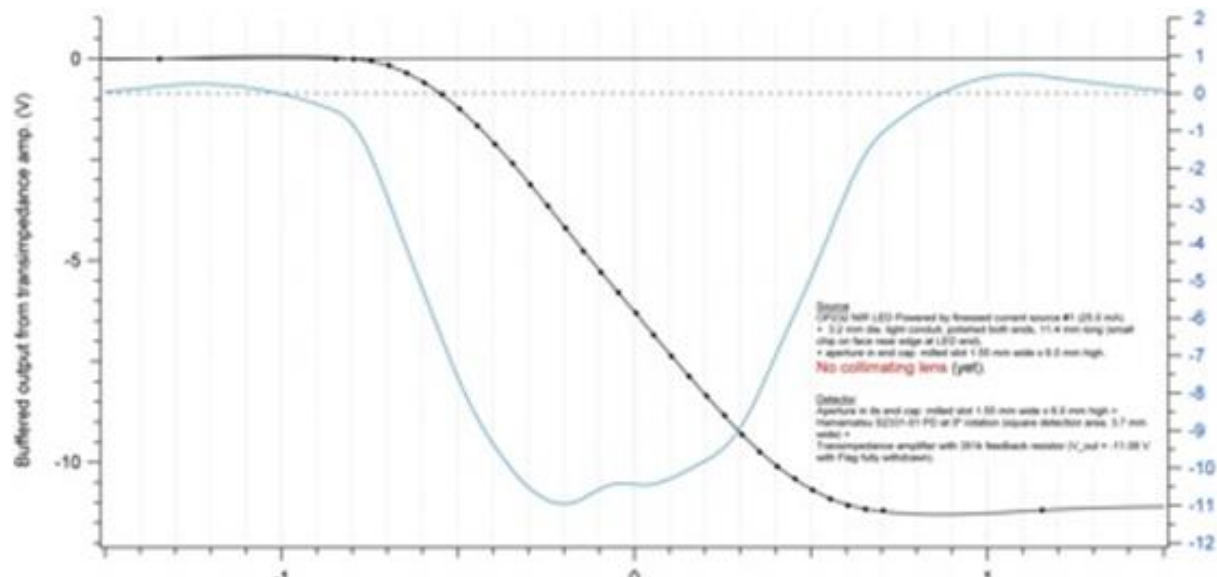

Payload Prototype Test

- Dummy mass suspended by $\Phi 0.2$ tungsten fibers
- Alignment of TM & RM is performed.
- OSEM assembly check is done.
- Tuning of flag position is done.

- Assembly and control test of the intermediate stage is to be done.

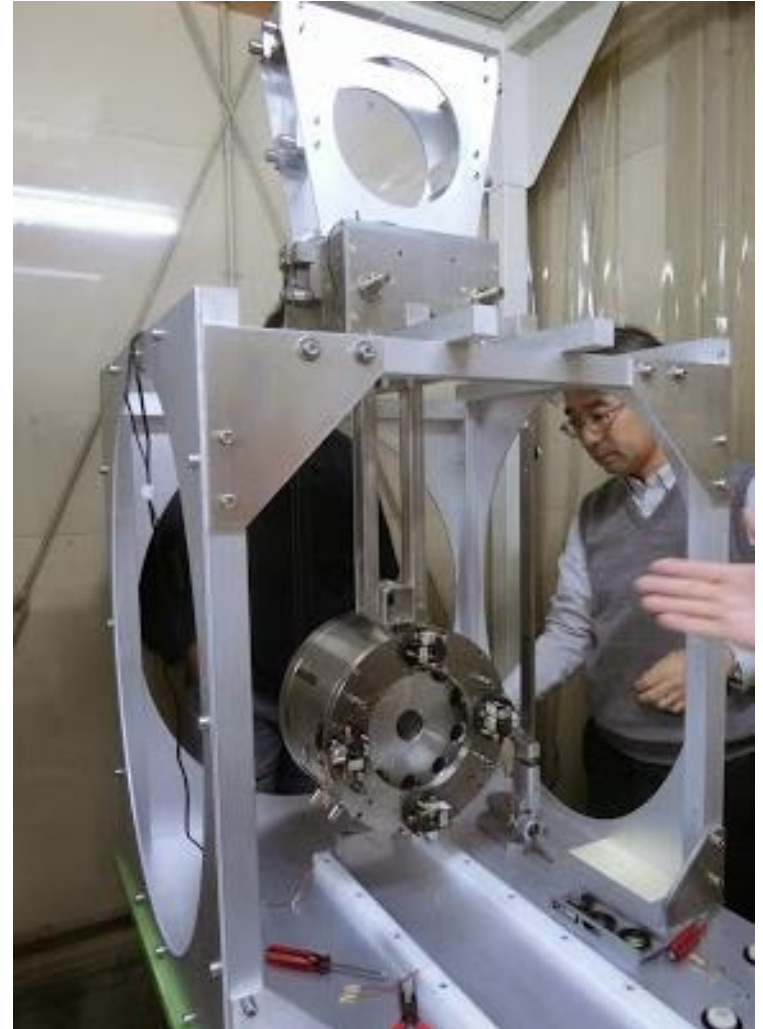

OSEM Prototypes

- Test with simple circuits for LED and PD
- No light guide is used.
- Misalignment of LED is a problem.
- Nick's circuit is to be tested.

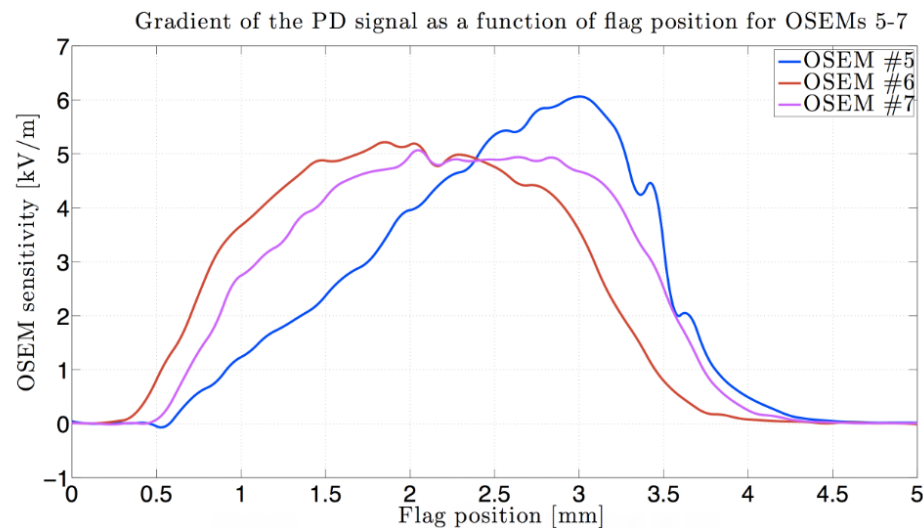
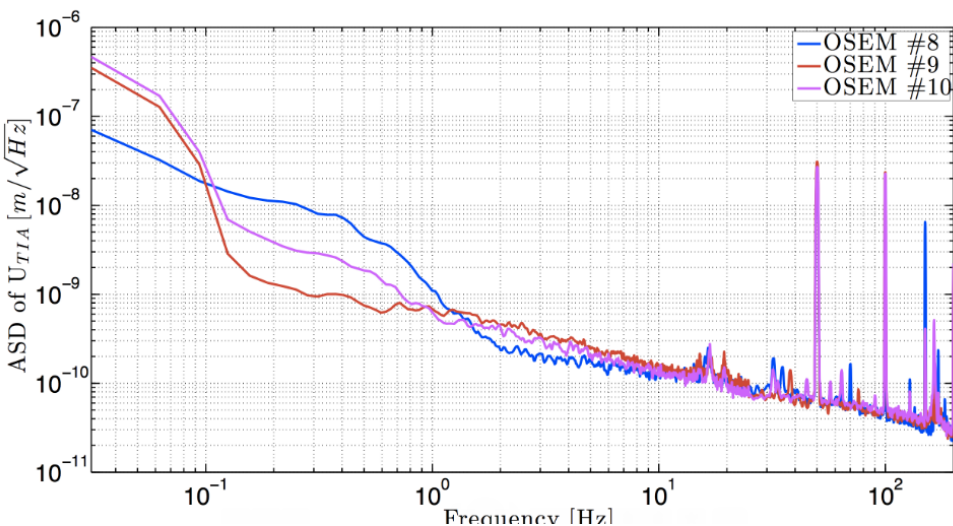
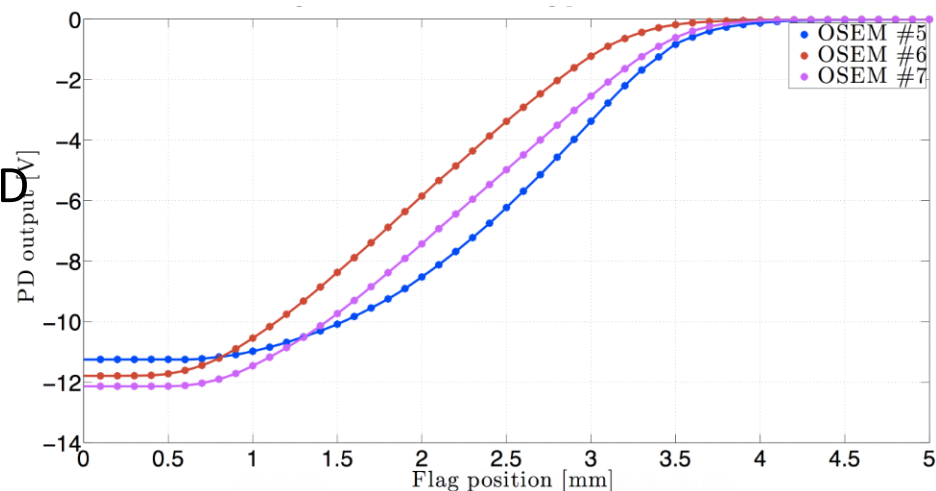

Optical Lever

- Light source: SLD 660 nm, 1mW
- Detector: PSD
- Large Drift ($\sim 1\mu\text{rad/h}$) of beam axis is observed in bench-top test

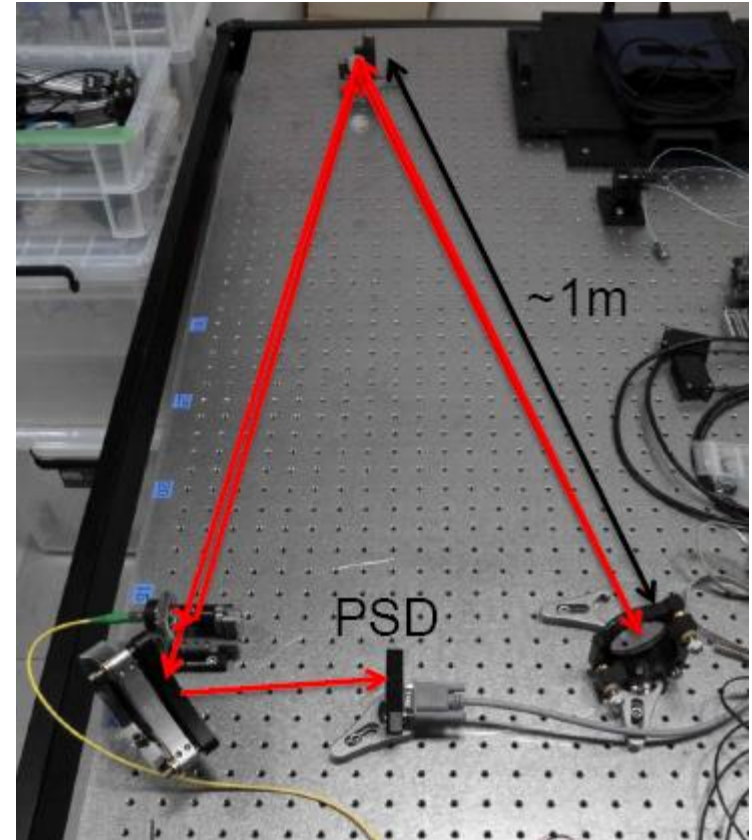
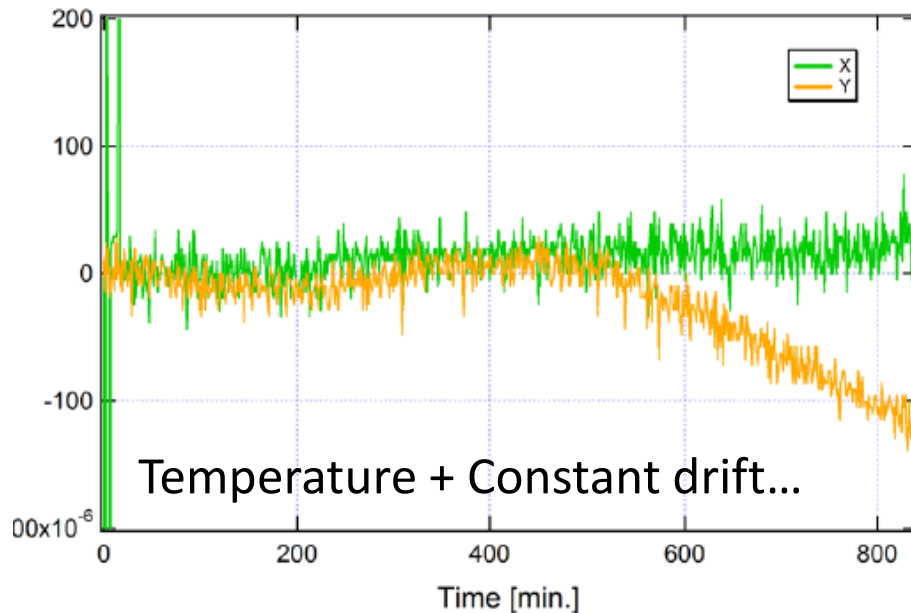

Summary

- Prototype tests of GAS filters, inverted pendulums and payload are on going.

Planned Tests:

- Assembly test of IM (Payload) : 2014.1
- Control test of IP in vacuum : 2014.2
- Prototype test of Full type-B : 2014.6

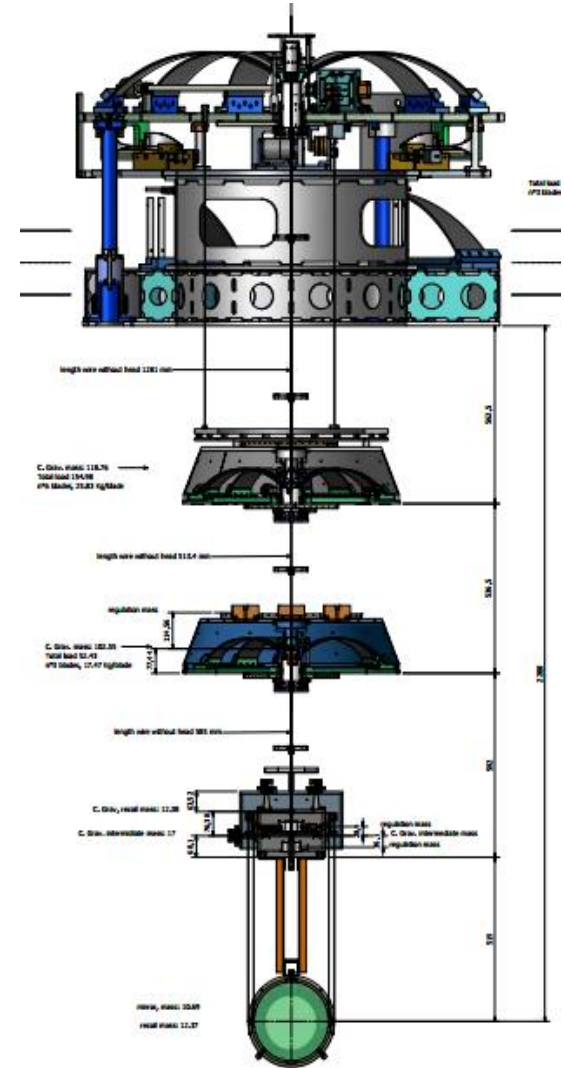

Cryogenic Suspension Design and Modeling

Status and Schedule

Cryogenic suspension

- Design and R&D are still on going...
- **Installation of first cryogenic payload starts from 2015.6**
- Preliminary design must be finished until ~2014.6.

Type-A SAS + Cryogenic Payload

- ~13 meter suspension housed in two-layer tunnel
- 6 stages of GAS filters

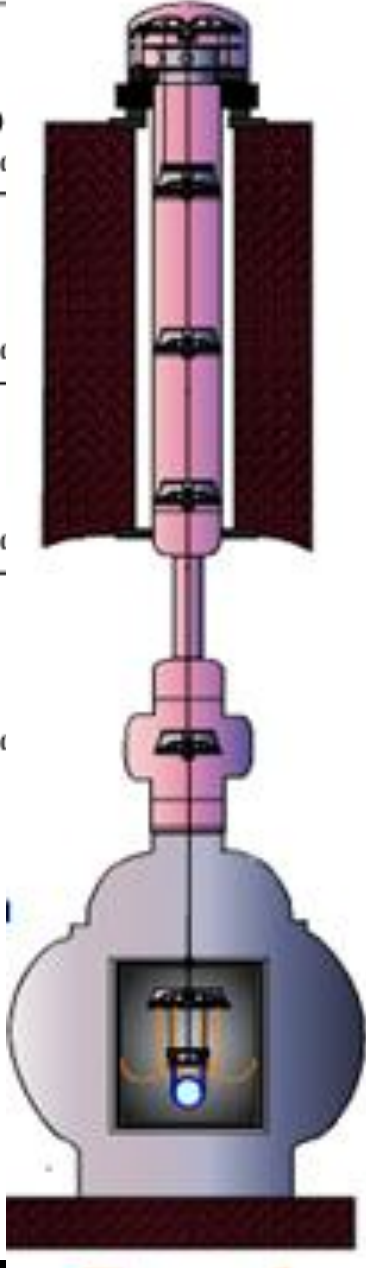
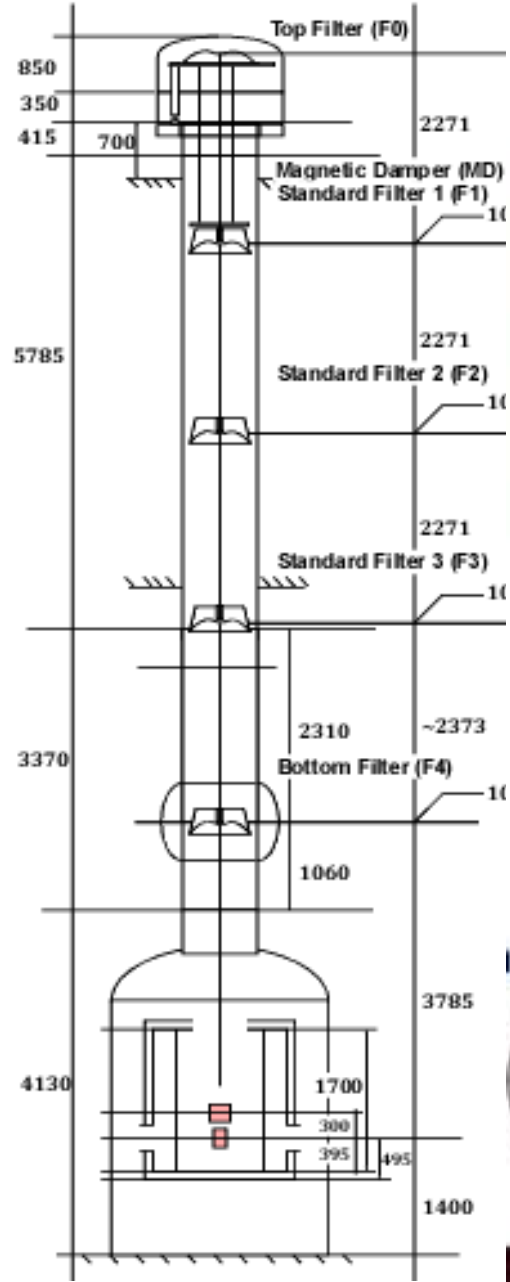

Cryogenic Payload Requirement

Cryogenic Payload Preliminary Design

- Triple pendulum
- Test mass is suspended by thick sapphire fibers for heat subtraction
- Heat links are connected from the cryocooler

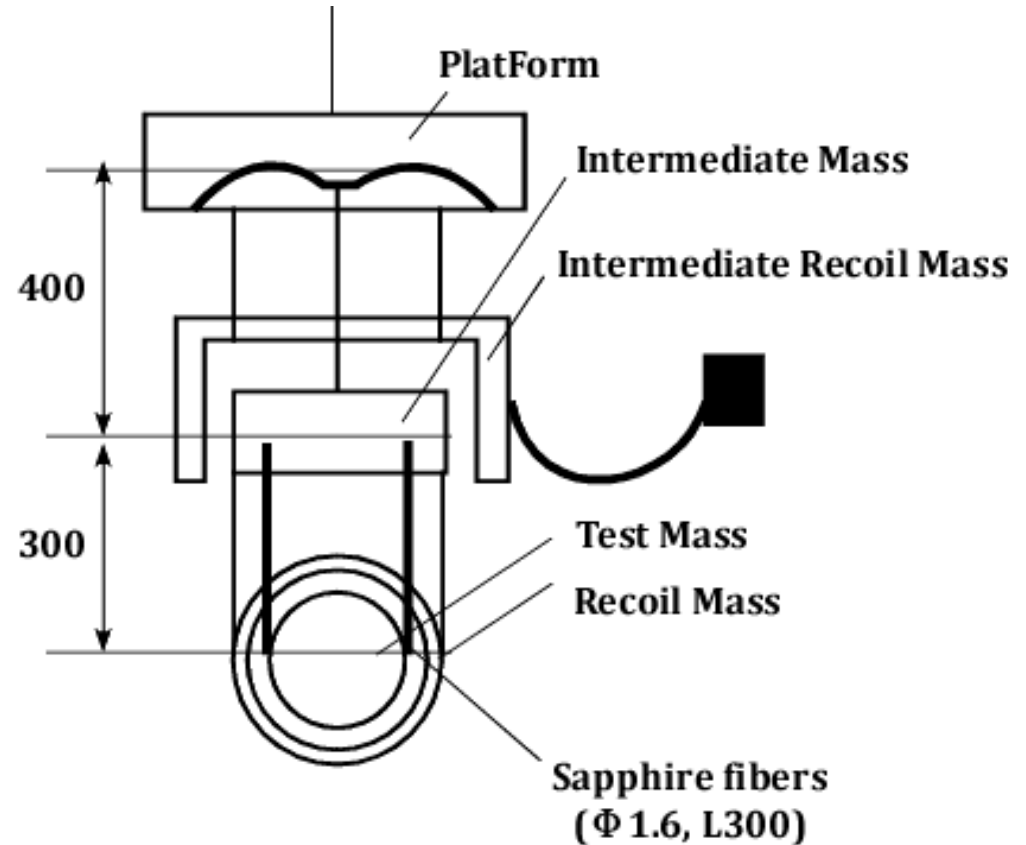

Heat Flow in Steady State

- 1W heat absorption from laser is assumed.
- Pure aluminum (5N) heat links are used for heat conduction.

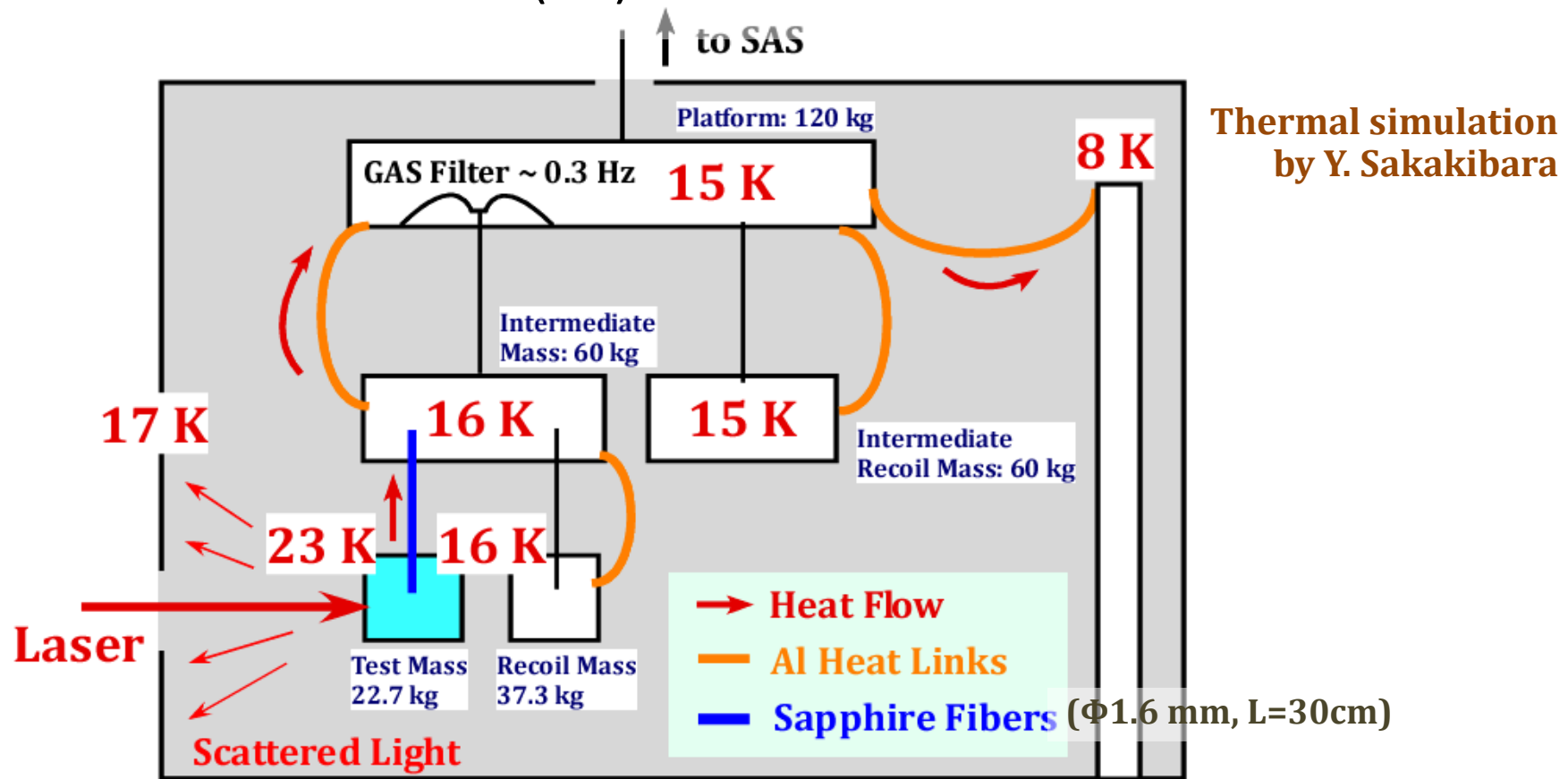

Problems of Cryogenic Suspension (1)

- **Thick sapphire fibers have large stiffness in stretch and bending**
 - Vertical resonance at ~ 120 Hz appears in thermal noise spectrum.
 - Difficulty in balancing the tension due to small stretching length of fibers ($\sim 20 \mu\text{m}$)
 - Effective bending point is 5 cm away from suspension point due to large stiffness of bending

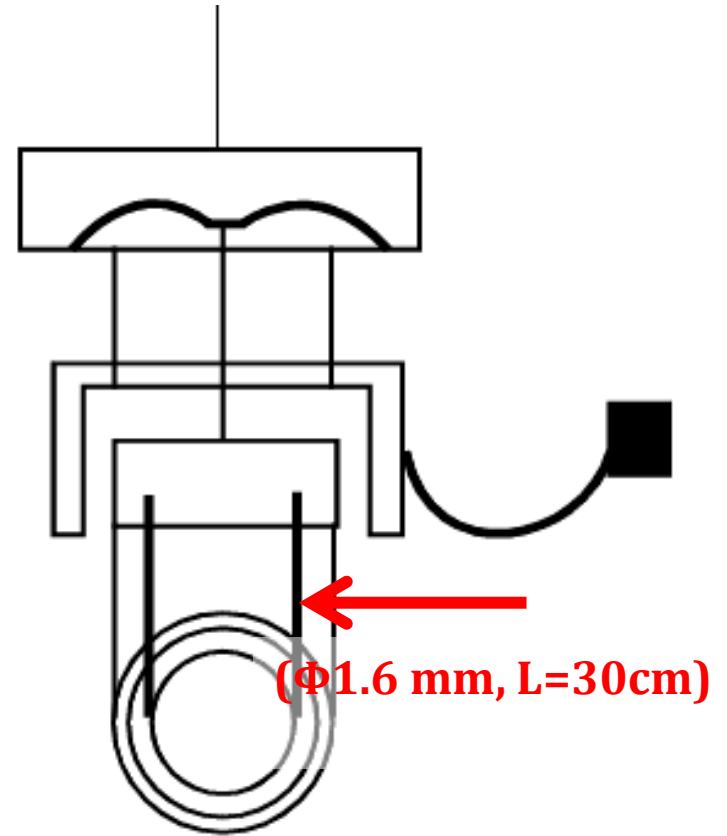

Suspension Thermal Noise

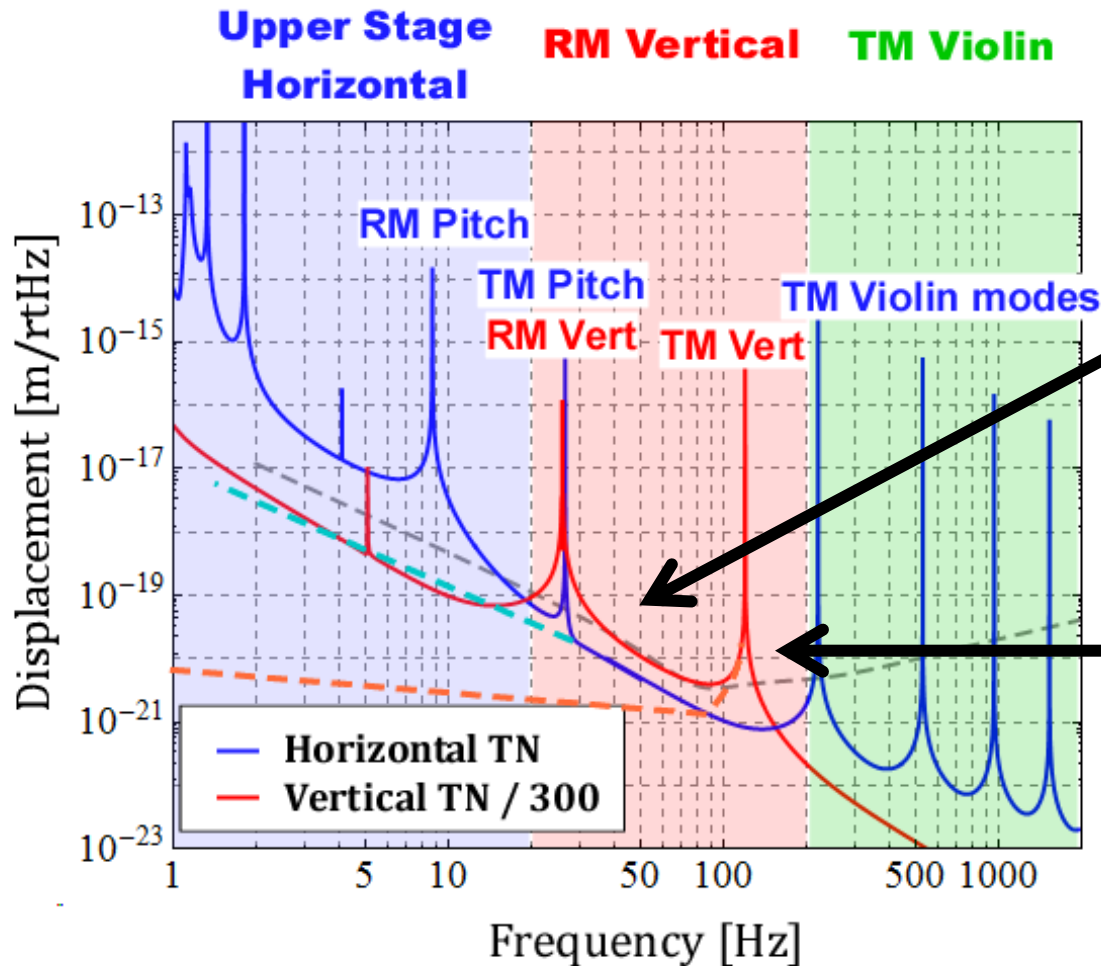

Thermal fluctuation at RM & IM transmit directly to the mirror

Huge peak at most sensitive frequency!!

Splitting of Violin Modes

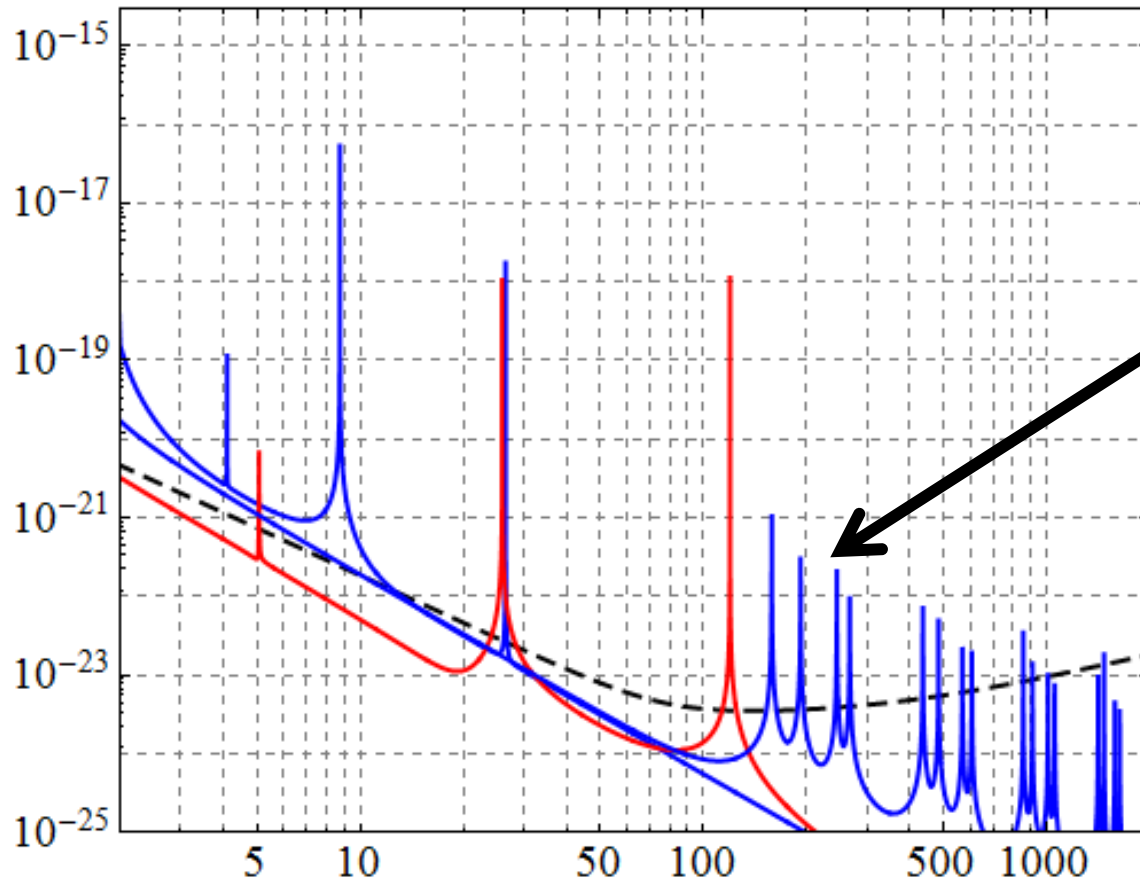

Violin modes can be split into 4 different peaks

Heat Link Transmission

- **Thick sapphire fibers have large stiffness in stretch and bending**
 - Vertical resonance at ~ 120 Hz appears in thermal noise spectrum.
 - Difficulty in balancing the tension due to small stretching length of fibers ($\sim 20 \mu\text{m}$)
 - Effective bending point is 5 cm away from suspension point due to large stiffness of bending

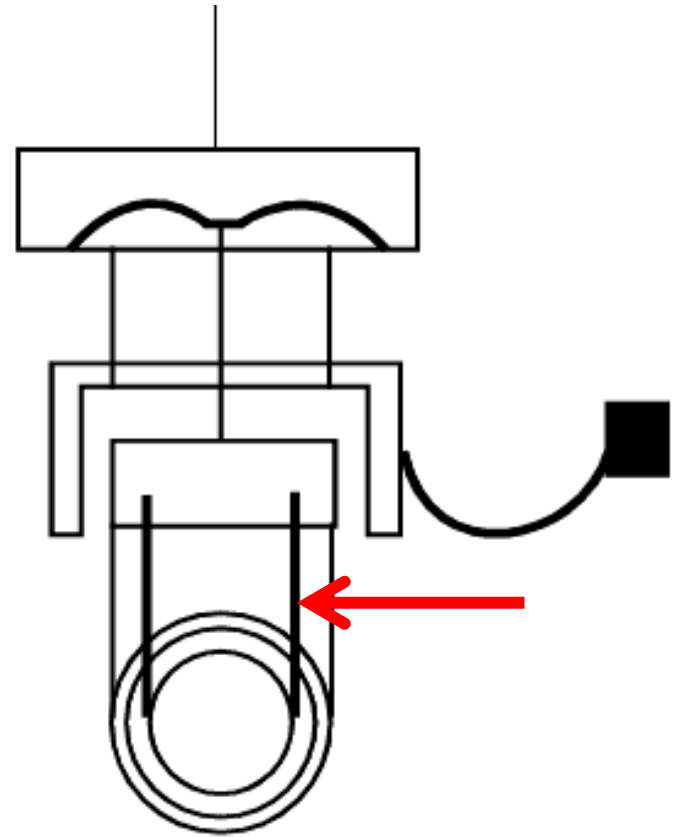

Problems

- Vibration transmitted via heat links is too large.

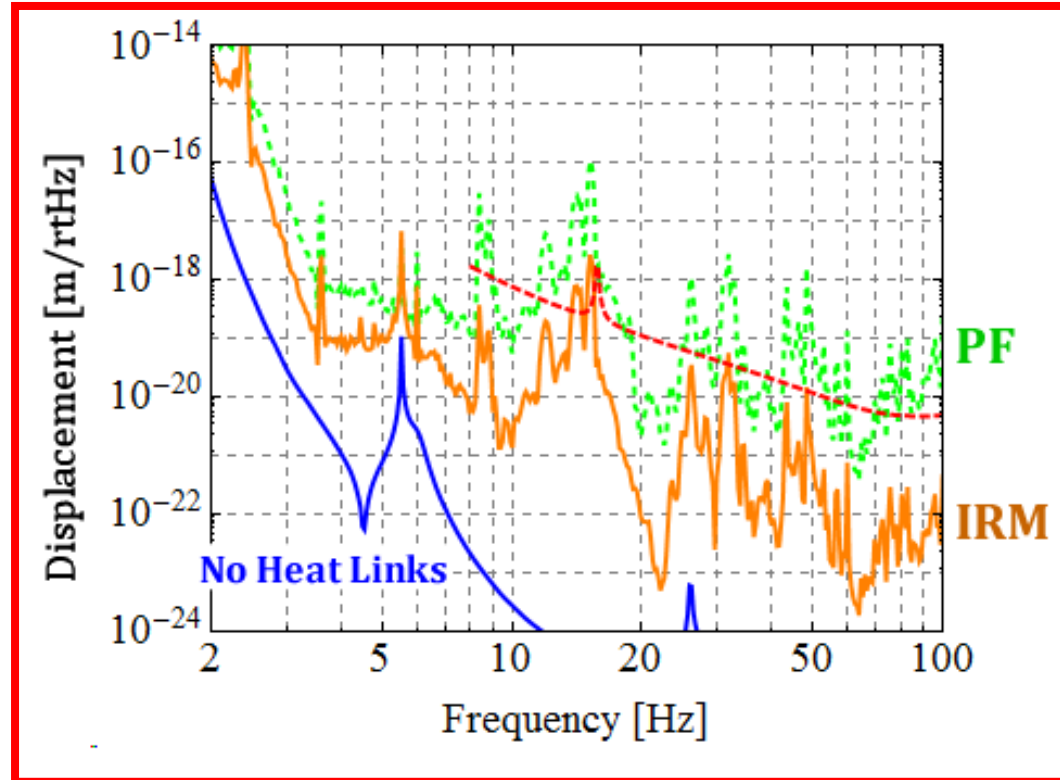

Cryo-Payload Design Consideration

Cryogenic Payload Design Starting Point

- Triple pendulum design
- Cryogenic GAS filter
- Sapphire springs
- Sapphire fibers ($\Phi 1.6$, L300)
- Aluminum wires for heat conduction

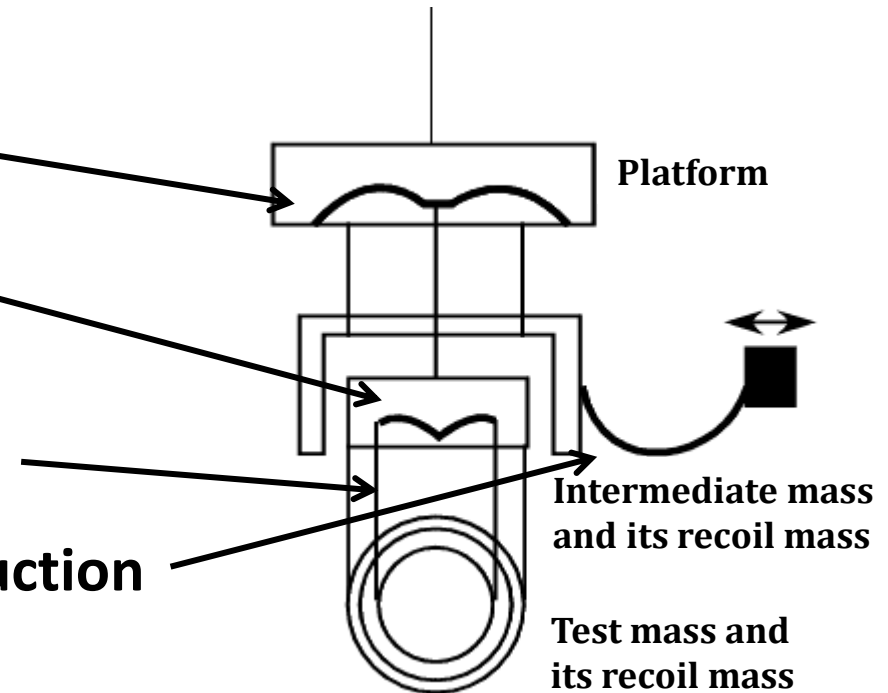

Heat Link Design and Vibration Transmissivity

- Pure aluminum ($E=70\text{GPa}$, $\text{Loss}=1\text{E-}2$)
- Semi-circular shape with $R150$, $L=470$
- Number of fibers: $2 \times 2=4$ (symmetric cabling)
- Each fiber consists of 45 strands with $\Phi 0.15$

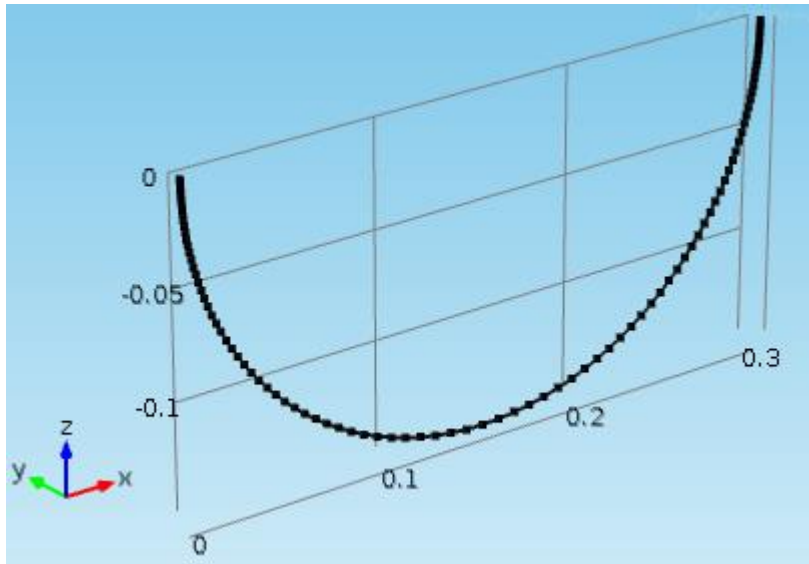

Simulated TF of a strand fiber:
Attached to a 50kg Mass

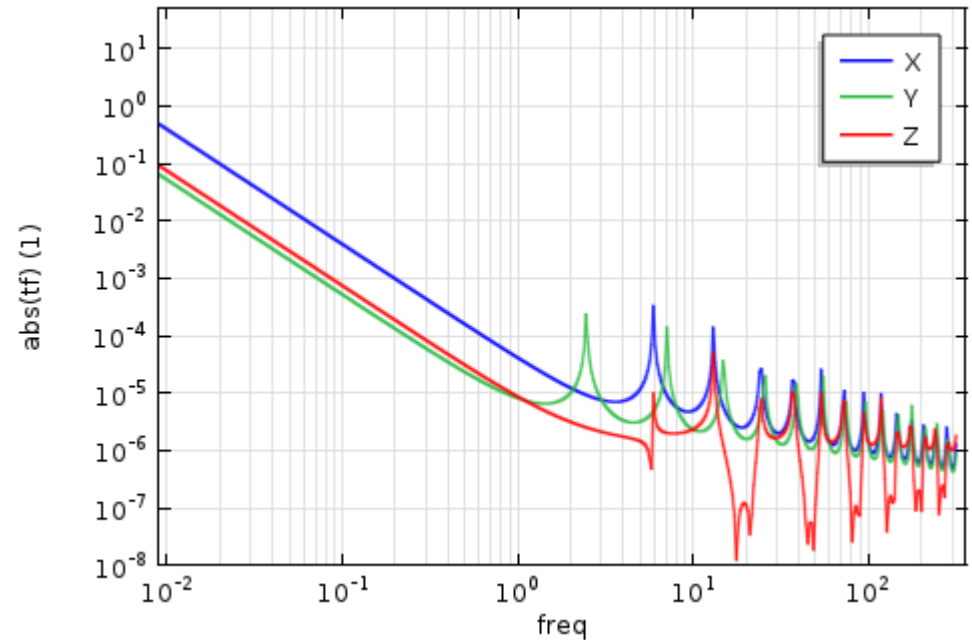

Cryostat Vibration Model

- From CLIO:

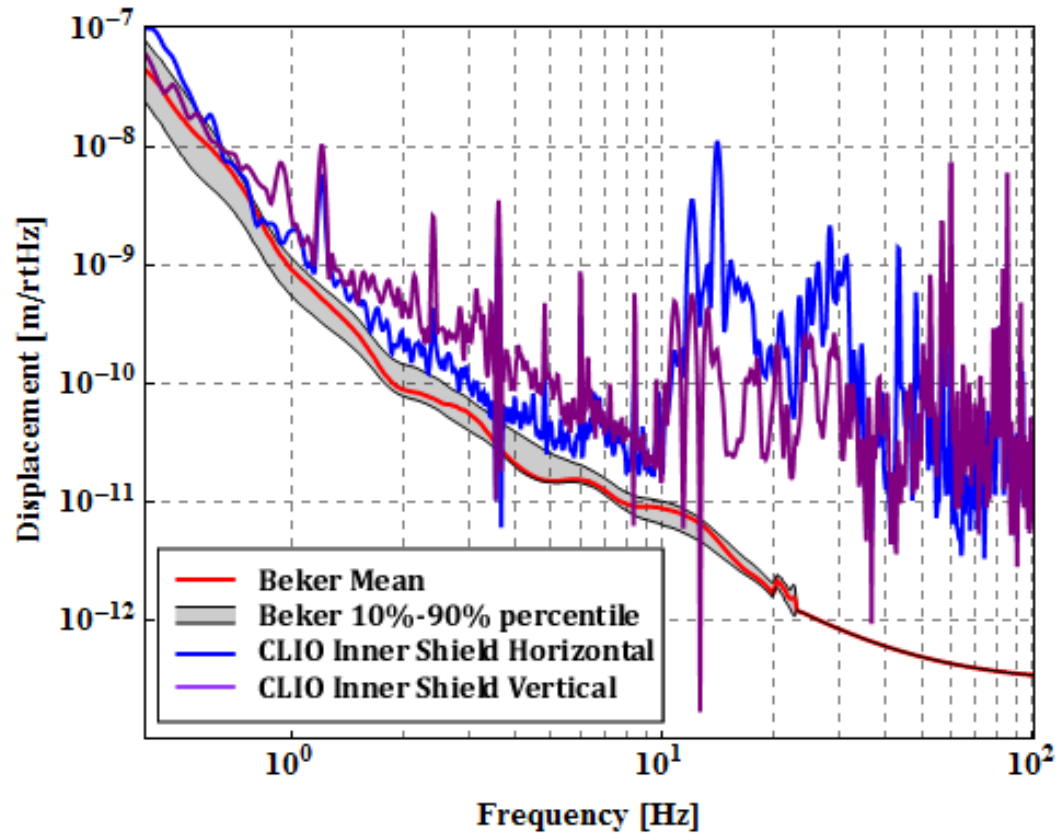

Vibration via Heat Links

- GAS filter @Platform tuned at 0.5 Hz
- Sapphire cantilever with 10 Hz bounce frequency

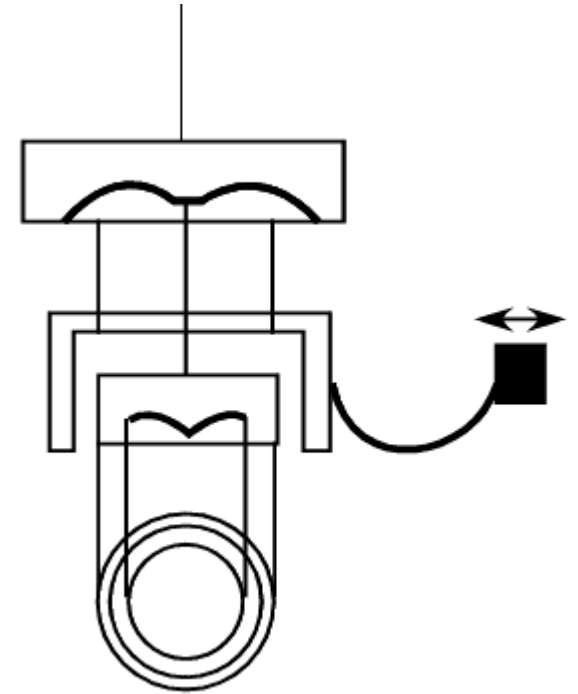
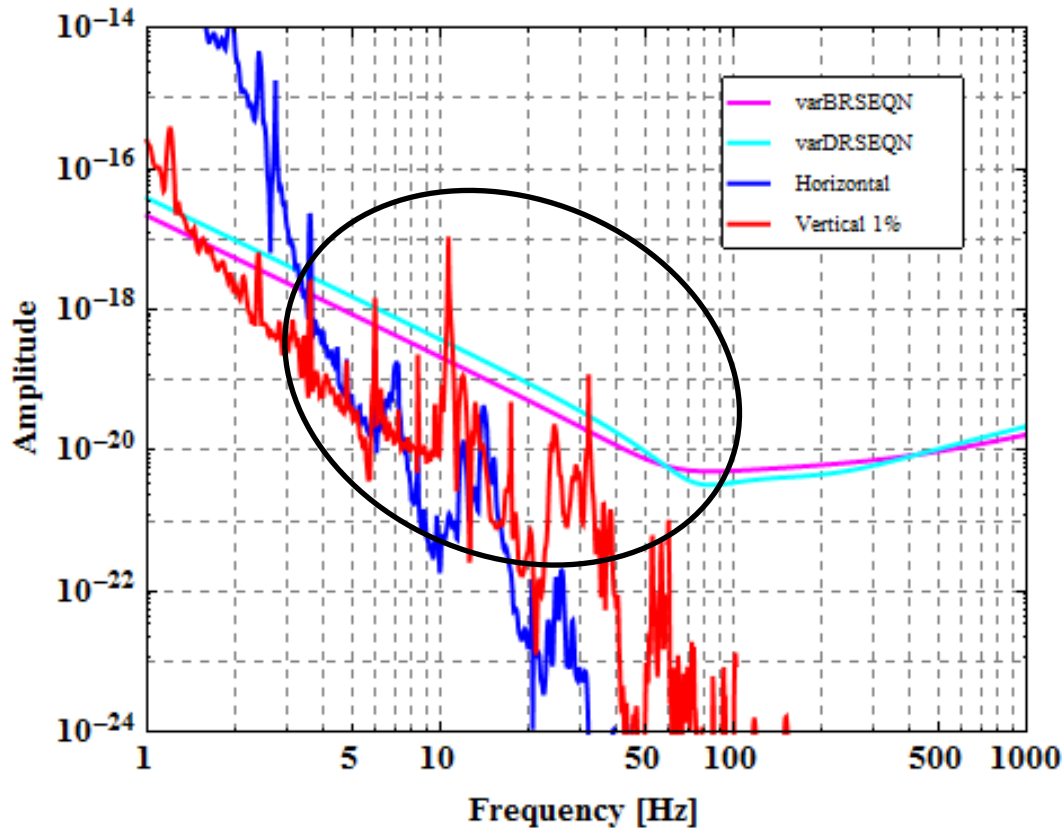

Vibration via Heat Links

- Additional vertical isolation with 2 Hz spring
- 2-4 orders of magnitude margin above 10 Hz

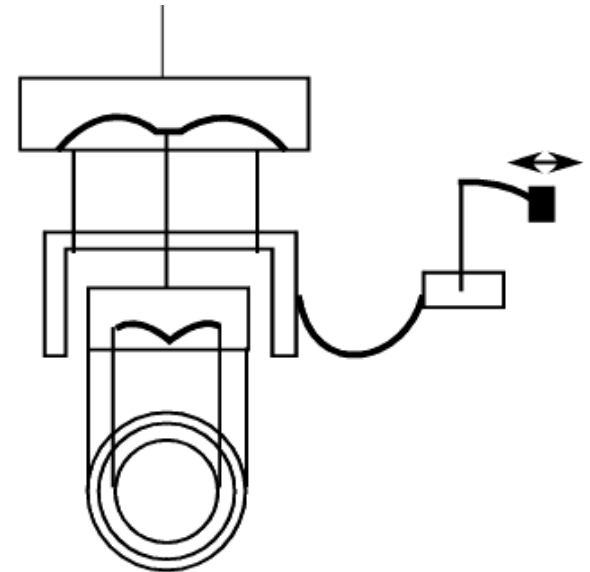
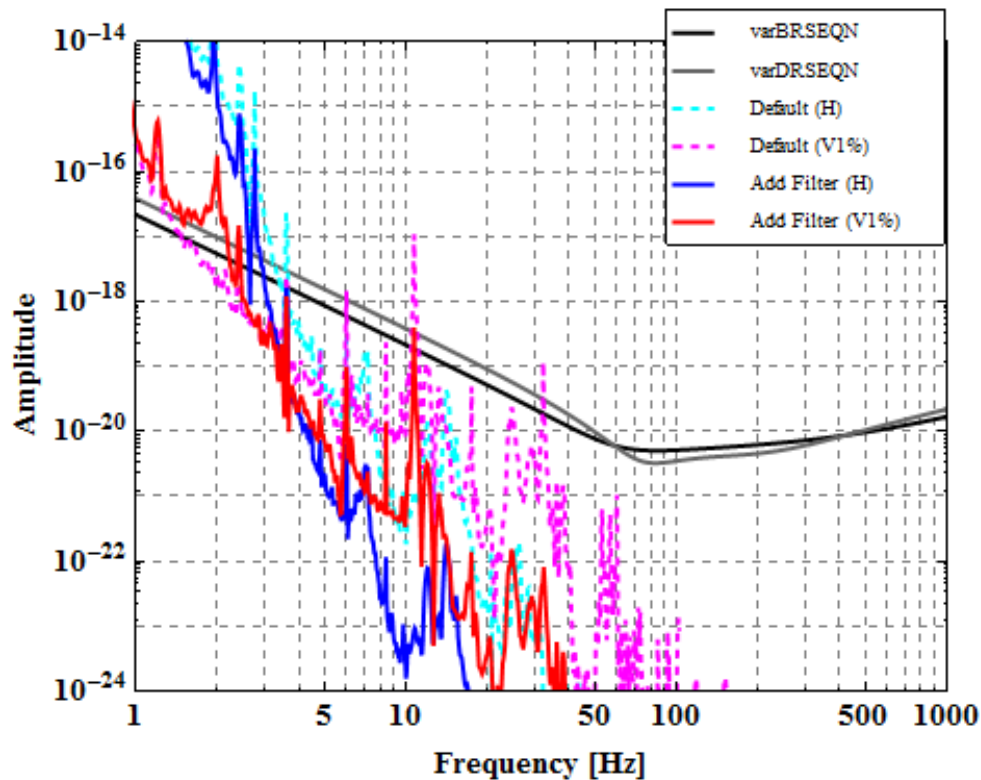

Suspension Thermal Noise

- GAS filter @Platform: $Q=1E3$
- Sapphire cantilever : $Q=1E6$

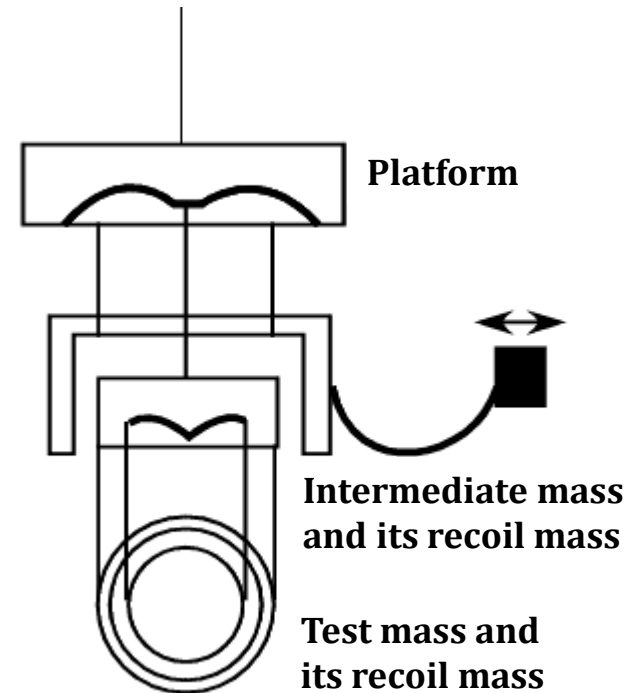
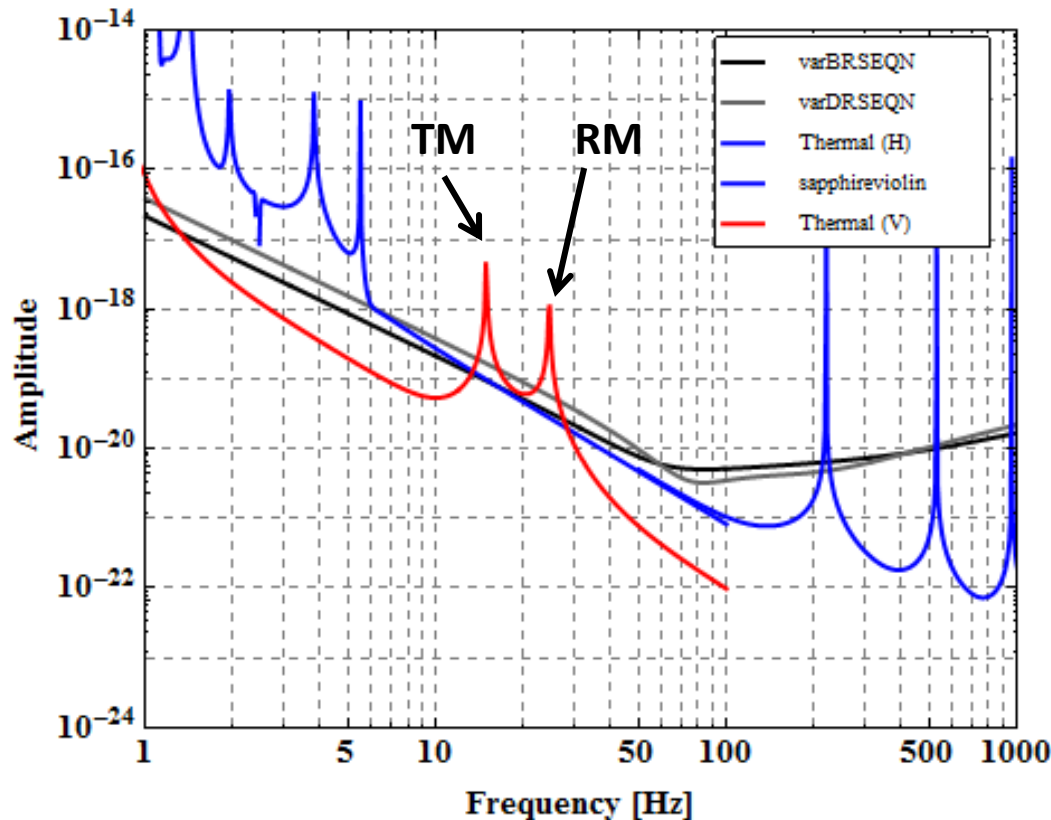

Suspension Thermal Noise

- GAS filter @Platform: $Q = 1E3 \rightarrow 10$
- Thermal noise of GAS filter is important!!

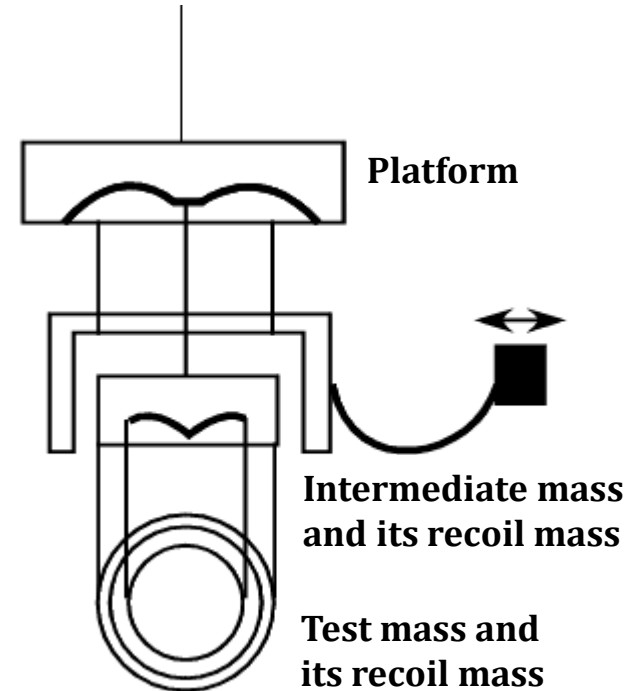
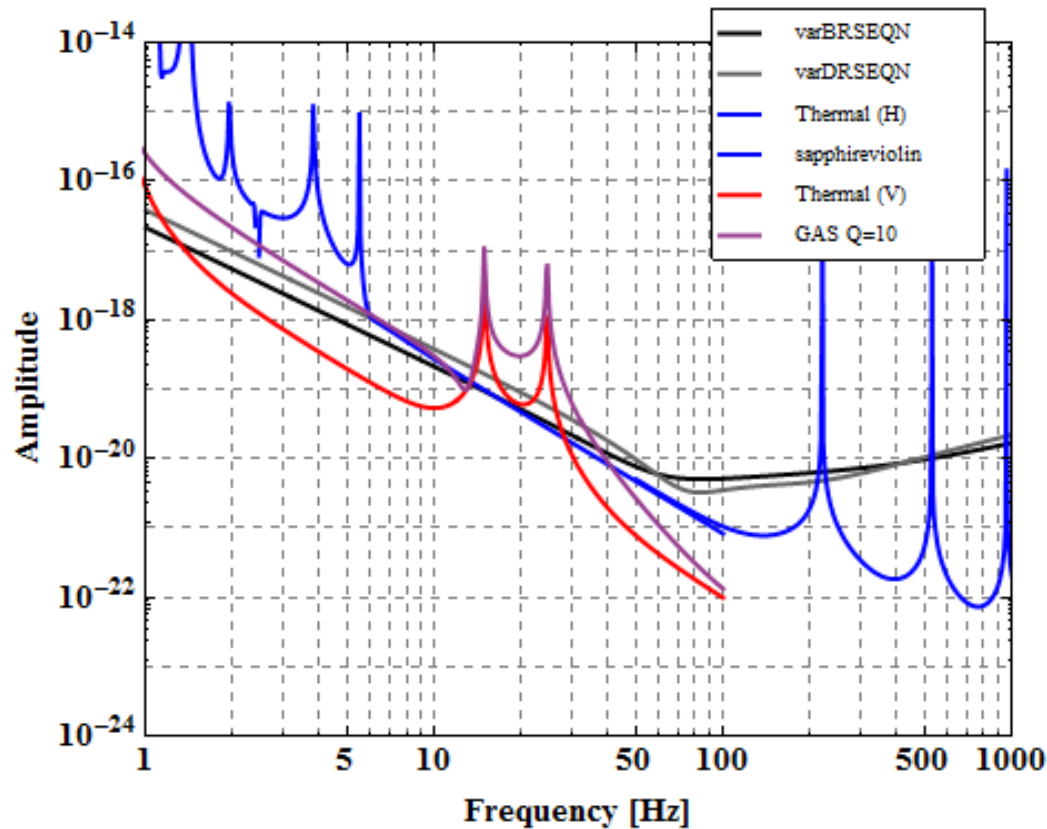

Suspension Thermal Noise

- Resonance @20 Hz can be removed when the recoil mass is suspended from intermediate recoil mass

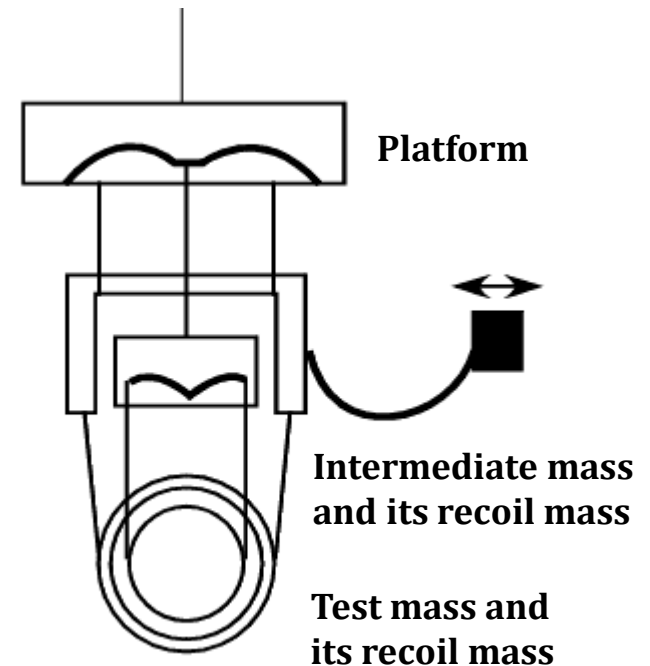
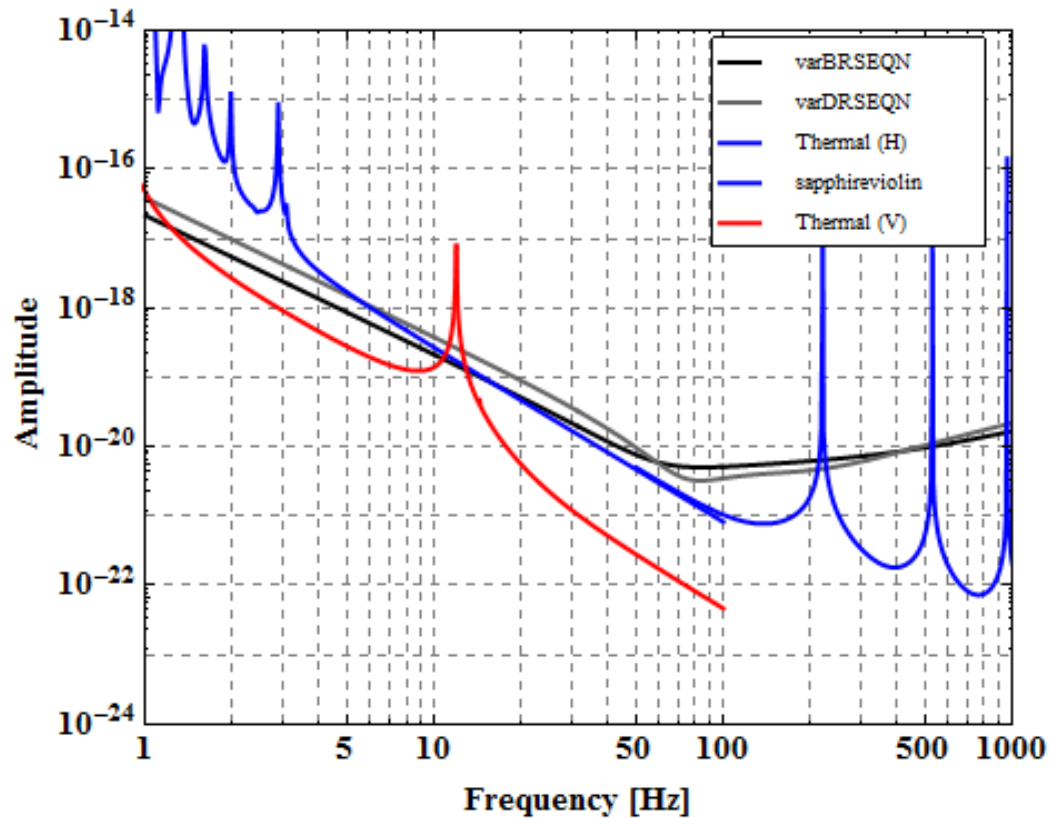

Consideration

- Thermal noise & heat link vibration can be OK in this topology.
- **Controllability, control noise should be investigated.**
- How to compensate thermal drift of GAS filter?
- 10 Hz sapphire cantilever springs can be achieved?
- Good Q achieved? Any degradation by heat links btw masses?

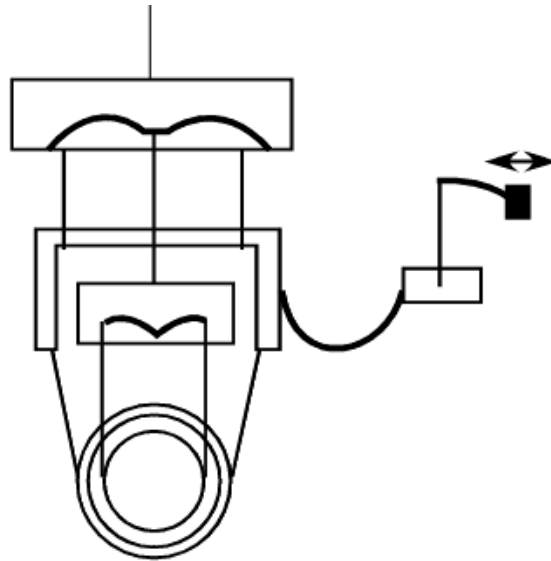

Modeling Tools

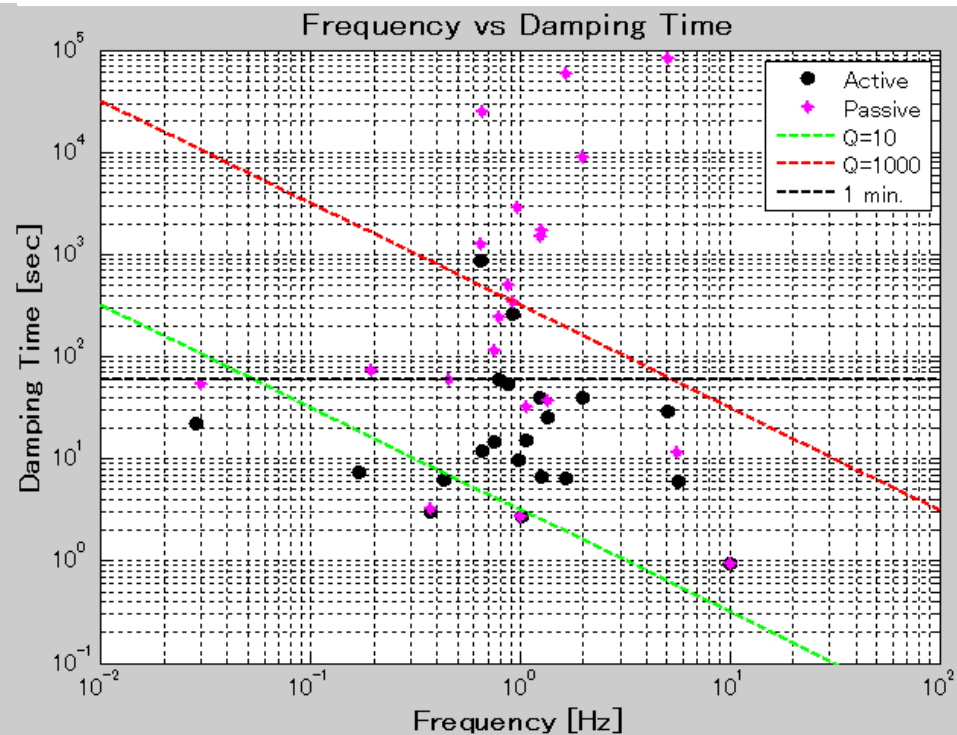
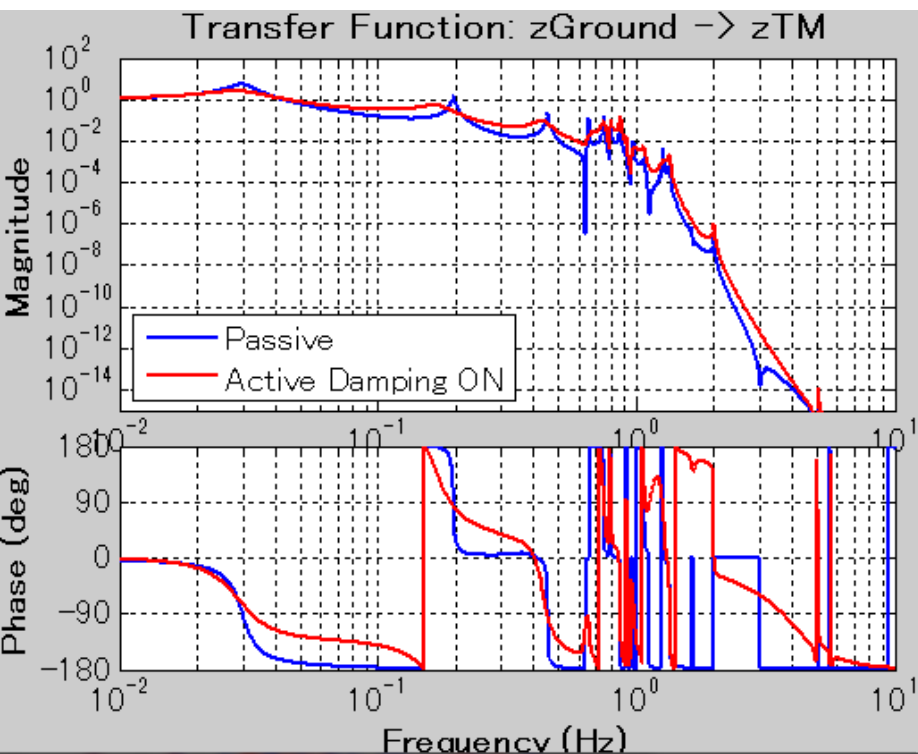

Modeling and simulation are on going...

Cryogenic Payload Tentative Parameters

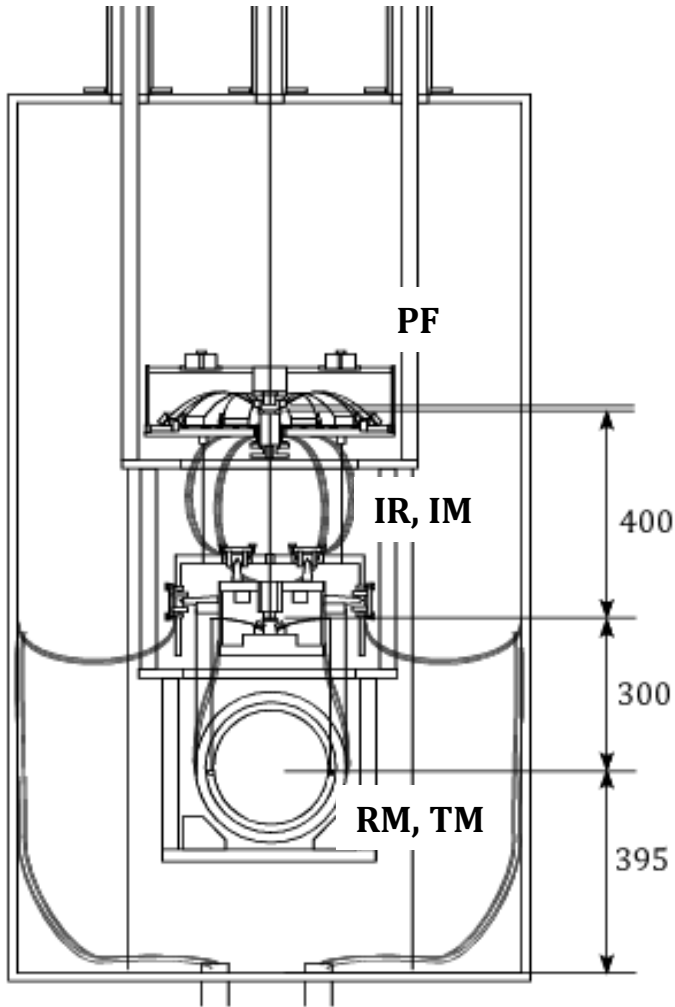

Mass Distribution

Platform	PF	62 kg
Intermediate Recoil Mass	IR	45 kg
Intermediate Mass	IM	53 kg
Recoil Mass	RM	34 kg
Test Mass	TM	23 kg
Total		217 kg

Spring Rate

	Q	F ₀
GAS Filter at PF-IM	1E3	0.5 Hz
Sapphire springs at IM-TM	1E6	10 Hz