

**NOTES CONTINUED:**  
 5. SCRIBE, ENGRAVE, LASER MARK OR MECHANICALLY STAMP (NO DYES OR INKS) A UNIQUE THREE DIGIT SERIAL NUMBER & REVISION NUMBER ON EACH PART. SERIAL NUMBERS START AT 001 FOR THE FIRST ARTICLE AND PROCEED CONSECUTIVELY. BAG AND TAG PARTS WITH THEIR DRAWING PART NUMBER, REVISION, VARIANT OR "TYPE" (IF APPLICABLE), AND QUANTITY. IF PARTS ARE TOO SMALL TO SCRIBE, BAGGING AND TAGGING ALONE IS SUFFICIENT.  
 EXAMPLE (PART): 001-v1  
 EXAMPLE (TAG): DXXXXXX-VY, TYPE-XX, QTY: TBD

- 6. APPROXIMATE WEIGHT = .018 LB.
  - 7. ALL PARTS SHALL BE MANUFACTURED IN ACCORDANCE WITH LIGO SPECIFICATION E0900364.
  - 8. ALL MATERIAL IS TO BE VIRGIN MATERIAL (i.e. NO WELD REPAIRS, PLUGS OR RECYCLED MATERIAL). NO REPAIRS SHALL BE MADE UNLESS APPROVED IN ADVANCE, AND IN WRITING, BY LIGO LABORATORY. REFER TO LIGO-E0900364.
- △ POST-MACHINED FEATURE MODIFICATIONS, PER DCN E1300250-x0

REV.	DATE	DCN #	DRAWING TREE #
v1	08-FEB-2013	E1300092-x0	E1300097-v1
v2	01-APR-2013	E1300250-x0	E1300097-v2
-	-	-	-

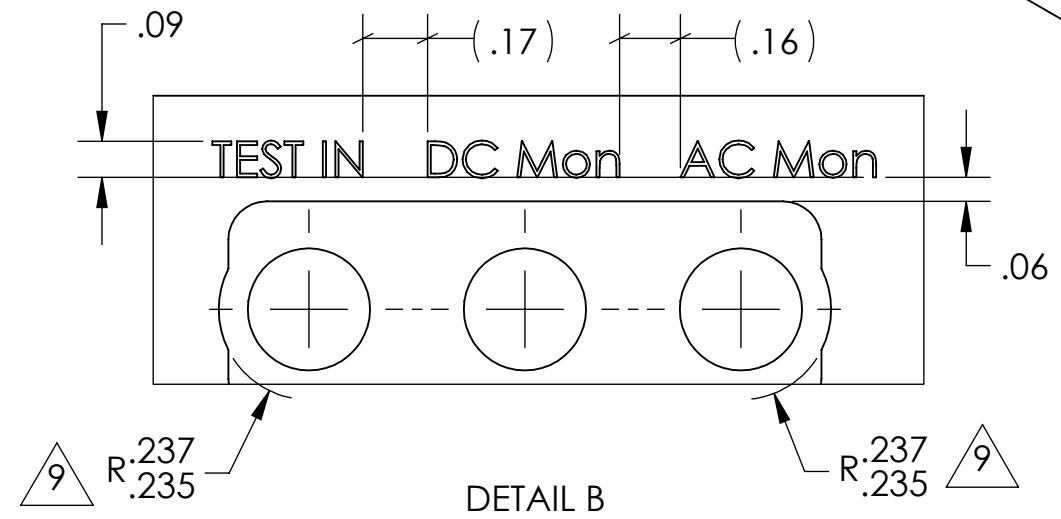
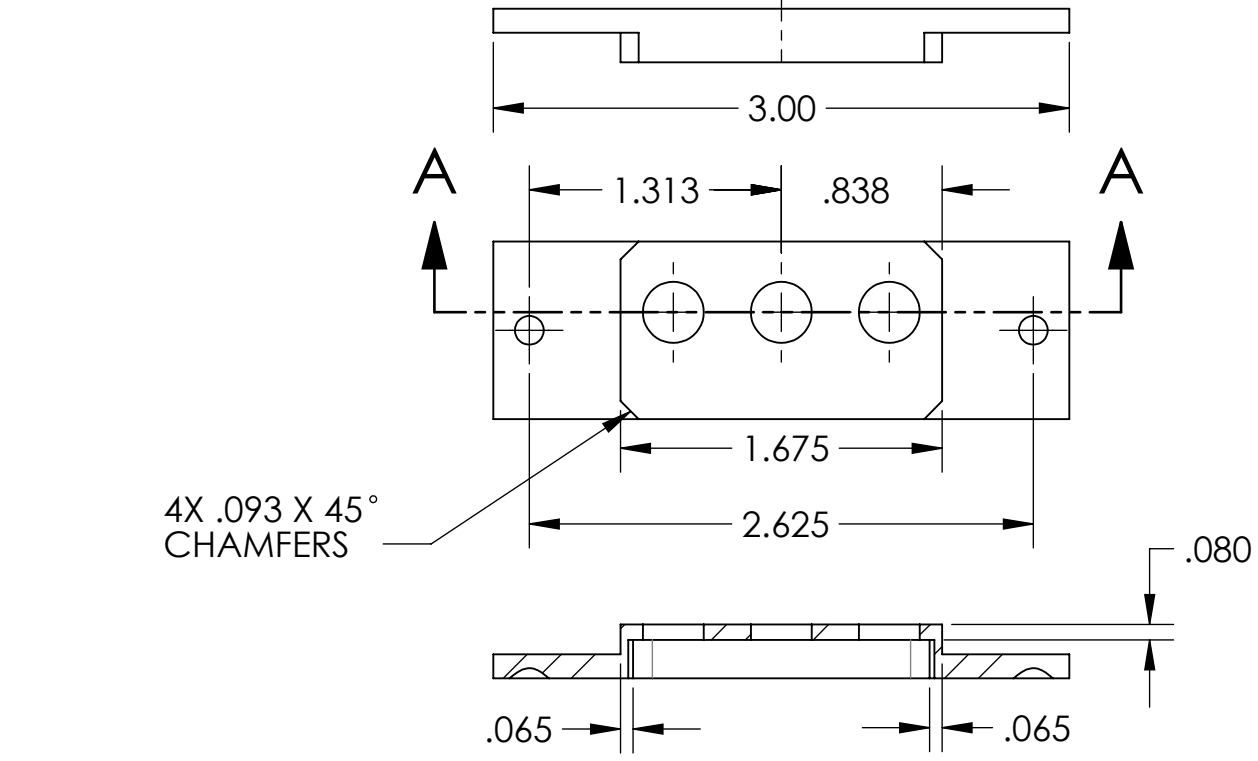
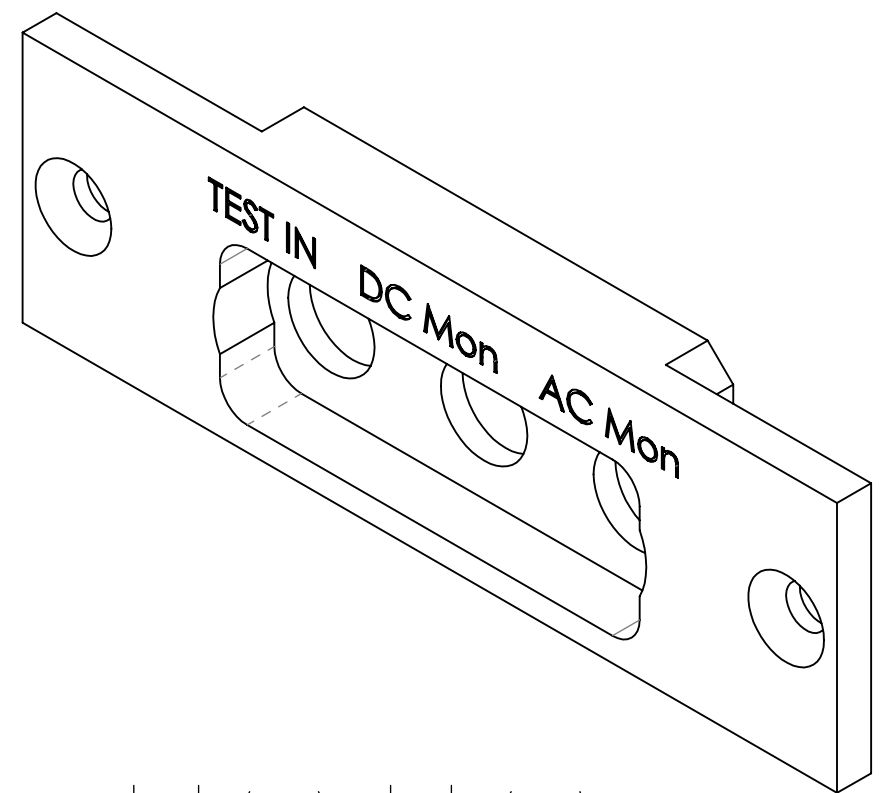
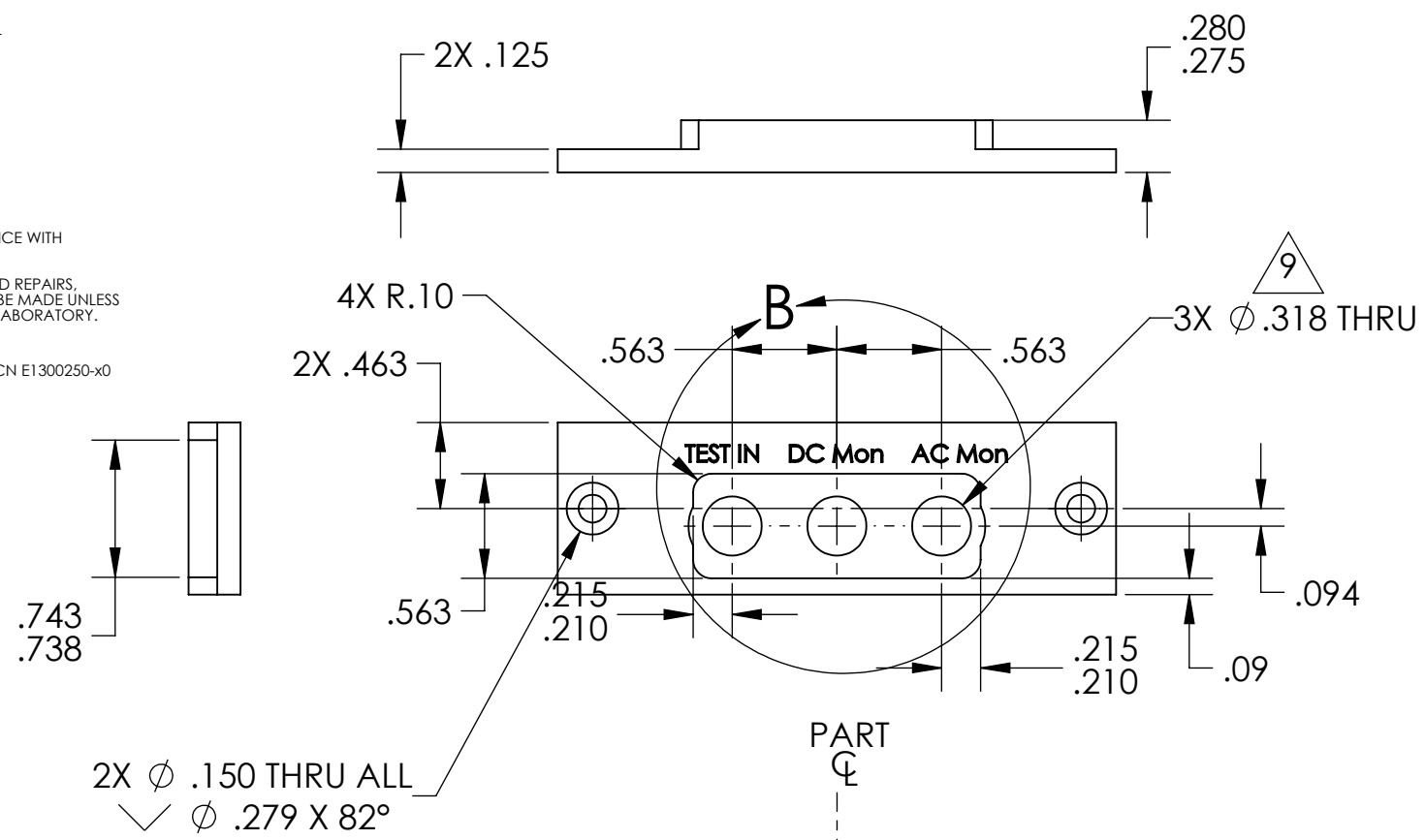

D1300076\_SMA BULKHEAD COVER, PART PDM REV: X-005, DRAWING PDM REV: X-006

**NOTES AND TOLERANCES: (UNLESS OTHERWISE SPECIFIED)**

DIMENSIONS ARE IN INCHES

TOLERANCES:  
 .XX ± .01  
 .XXX ± .005  
 ANGULAR ± °

1. INTERPRET DRAWING PER ASME Y14.5-1994.  
 2. REMOVE ALL SHARP EDGES, .005-.015, FOR MACHINED PARTS. ROUND ALL EDGES APPROXIMATELY R.02  
 3. DO NOT SCALE FROM DRAWING.  
 4. ALL MACHINING FLUIDS MUST BE FULLY SYNTHETIC, FULLY WATER SOLUBLE AND FREE OF SULFUR, SILICONE, AND CHLORINE.

**MATERIAL** Polyetheretherketone (PEEK) **FINISH** 63 μinch

CALIFORNIA INSTITUTE OF TECHNOLOGY MASSACHUSETTS INSTITUTE OF TECHNOLOGY		<b>PART NAME</b> SMA BULKHEAD COVER	
<b>SYSTEM</b> ADVANCED LIGO	<b>SUB-SYSTEM</b> AOS	<b>DESIGNER</b> M. JACOBSON 23-JAN-2013 <b>DRAFTER</b> M. JACOBSON 30-JAN-2013 <b>CHECKER</b> B. ABBOTT 01-APR-2013 <b>APPROVAL</b> HEPTONSTALL 01-APR-2013	<b>SIZE DWG. NO.</b> B D1300076 <b>SCALE:</b> 2:1 <b>PROJECTION:</b>
<b>NEXT ASSY</b> D1201065	<b>REV.</b> v2	SHEET 1 OF 1	