

NOTES CONTINUED:

5. SCRIBE, ENGRAVE (A VIBRATORY TOOL MAY BE USED), LASER MARK OR MECHANICALLY STAMP (NO INKS OR DYES) DRAWING PART NUMBER, REVISION (AND VARIANT OR "TYPE" IF APPLICABLE) ON NOTED SURFACE OF PART FOLLOWED ON THE NEXT LINE WITH A THREE DIGIT SERIAL NUMBER. SERIAL NUMBERS START AT 001 FOR THE FIRST ARTICLE AND PROCEED CONSECUTIVELY. USE MINIMUM 0.12" HIGH CHARACTERS, UNLESS THE SIZE OF THE PART DICTATES SMALLER CHARACTERS. EXAMPLE: DXXXXXX-VY, TYPE-XX, S/N XXX

- 6. APPROXIMATE WEIGHT = 0.12 LB
- 7. MACHINE ALL SURFACES TO REMOVE OXIDES AND MILL FINISH. USE OF ABRASIVE REMOVAL TECHNIQUES IS NOT ALLOWED. REFER TO LIGO-E0900364
- 8. ALL PARTS SHALL BE MANUFACTURED IN ACCORDANCE WITH LIGO SPECIFICATION E0900364.
- 9. ALL MATERIAL IS TO BE VIRGIN MATERIAL (i.e. NO WELD REPAIRS, PLUGS OR RECYCLED MATERIAL). NO REPAIRS SHALL BE MADE UNLESS APPROVED IN ADVANCE, AND IN WRITING, BY LIGO LABORATORY. REFER TO LIGO-E0900364.

| REV. | DATE | DCN # | DRAWING TREE # |
|------|-------------|-------|----------------|
| v1 | 15-AUG-2012 | - | - |
| - | - | - | - |
| - | - | - | - |

D1201141_COVER, dLIGO TCS CO2P PD PREAMP ASSY, PART PDM REV: X-003, DRAWING PDM REV: X-003

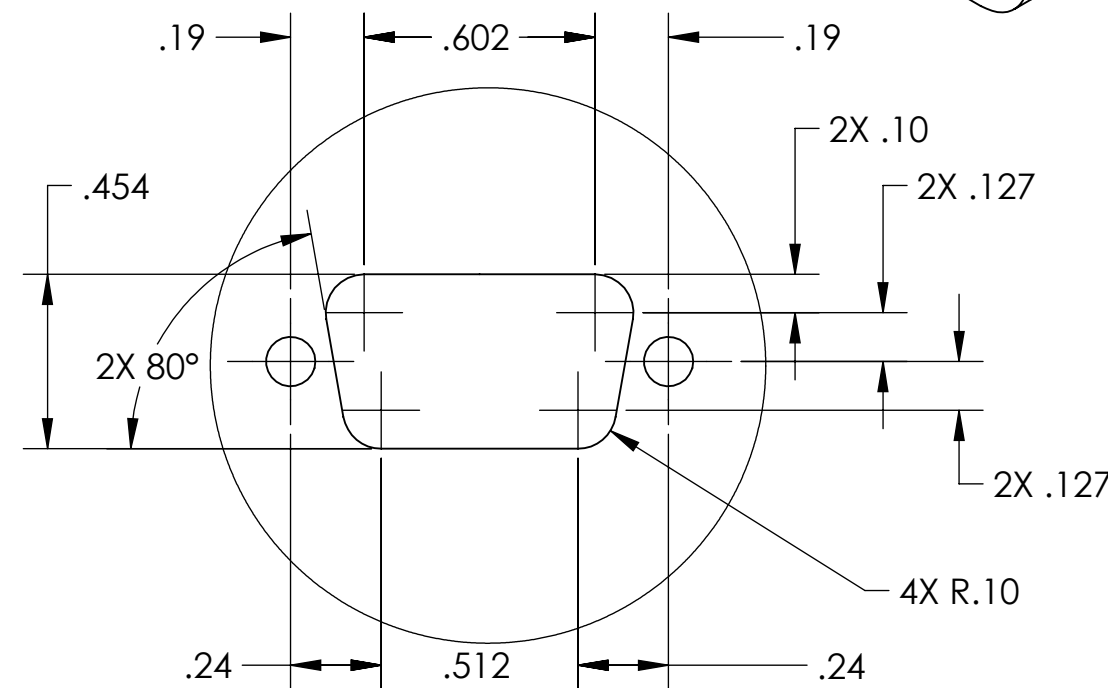
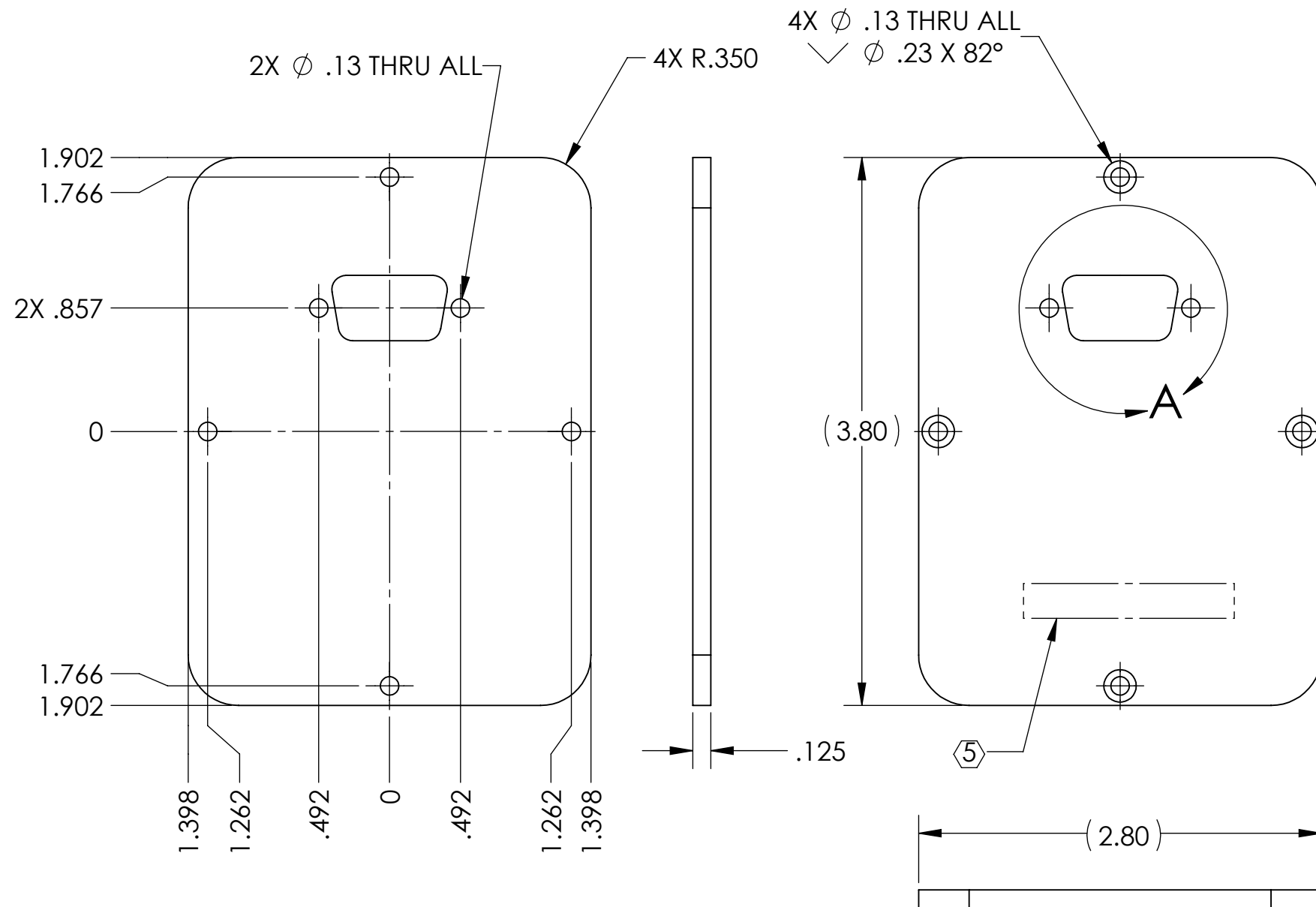

DETAIL A
SCALE 2 : 1

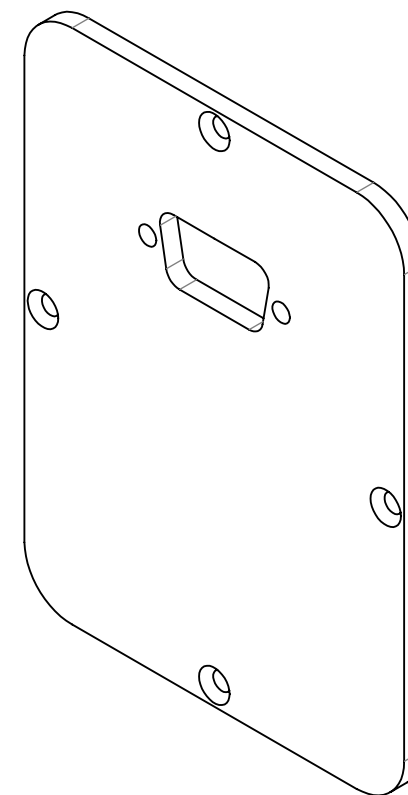

NOTES AND TOLERANCES: (UNLESS OTHERWISE SPECIFIED)

DIMENSIONS ARE IN INCHES

TOLERANCES:
 .XX ± .01
 .XXX ± .005
 ANGULAR ± 1.0°

1. INTERPRET DRAWING PER ASME Y14.5-1994.
 2. REMOVE ALL SHARP EDGES, .005-.015, FOR MACHINED PARTS. ROUND ALL EDGES APPROXIMATELY R.02 FOR SHEET METAL PARTS.
 3. DO NOT SCALE FROM DRAWING.
 4. ALL MACHINING FLUIDS MUST BE FULLY SYNTHETIC, FULLY WATER SOLUBLE AND FREE OF SULFUR, SILICONE, AND CHLORINE.

MATERIAL 6061 Alloy

FINISH 63 μ inch

| | | | |
|---|--|--------------------------------------|--------------------------|
| CALIFORNIA INSTITUTE OF TECHNOLOGY MASSACHUSETTS INSTITUTE OF TECHNOLOGY | | PART NAME | |
| SYSTEM ADVANCED LIGO | | COVER, dLIGO TCS CO2P PD PREAMP ASSY | |
| SUB-SYSTEM AOS | | DESIGNER | M. JACOBSON 08-AUG-12 |
| NEXT ASSY | | DRAFTER | M. JACOBSON 15-AUG-2012 |
| D1201065 | | CHECKER | B. ABBOTT 16-AUG-2012 |
| | | APPROVAL | HEPTONSTALLI 17-AUG-2012 |
| | | SIZE | DWG. NO. |
| | | B | D1201141 |
| | | SCALE | 1:1 |
| | | PROJECTION | |
| | | REV. | v1 |
| | | SHEET 1 OF 1 | |