

**NOTES: UNLESS OTHERWISE SPECIFIED**

1. INTERPRET DRAWING PER ASME Y14.5-1994.
2. REMOVE ALL SHARP EDGES .005-.015 ON ALL EDGES AND HOLES
3. DO NOT SCALE FROM DRAWING.
4. ALL MACHINE FLUIDS MUST BE FULLY SYNTHETIC, FULL WATER SOLUBLE AND FREE OF SULFUR, SILICONE AND CHLORINE PER LIGO DOCUMENT E0900237.
5. SCRIBE, ENGRAVE (A VIBRATORY TOOL MAY BE USED), LASER MARK (NO INKS OR DYES) DRAWING PART NUMBER, REVISION (AND VARIANT OR "TYPE" IF APPLICABLE) ON NOTED SURFACE OF PART FOLLOWED ON THE NEXT LINE WITH A THREE DIGIT SERIAL NUMBER. SERIAL NUMBERS START AT 001 FOR THE FIRST ARTICLE AND PROCEED CONSECUTIVELY. USE MINIMUM 0.12" HIGH CHARACTERS, UNLESS THE SIZE OF THE PART DICTATES SMALLER CHARACTERS.  
EXAMPLE: DXXXXXX-VY, TYPE-XX, S/N XXX  
DO NOT APPLY MARK ON SUPER #8 SIDE
6. ALL PARTS SHALL BE MANUFACTURED IN ACCORDANCE WITH LIGO SPEC E0900364.
7. ALL MATERIAL IS TO BE VIRGIN MATERIAL (I.E. NO WELD REPAIRS OR PLUGS) UNLESS APPROVED IN ADVANCE, IN WRITING, BY LIGO PER SPECIFICATION E0900364.
8. SURFACE FINISH TO BE AS-PROCESSED FROM MILL/SUPPLIER, FREE FROM SCRATCHES OR GOUGES.
9. SEE CAD FILE # D1200296.SLDPRT TO GENERATE ELLIPSE CURVES.
10. SEE FLAT-PATTERN CAD FILE FOR CHAMFER OF 13.62" DIAMETER HOLE.

REV.	DATE	DCN #	DRAWING TREE #
v1	17 FEB 2012	E1100335	-
v2	27 APR 2012	-	-
v3	25 JUN 2012	-	-

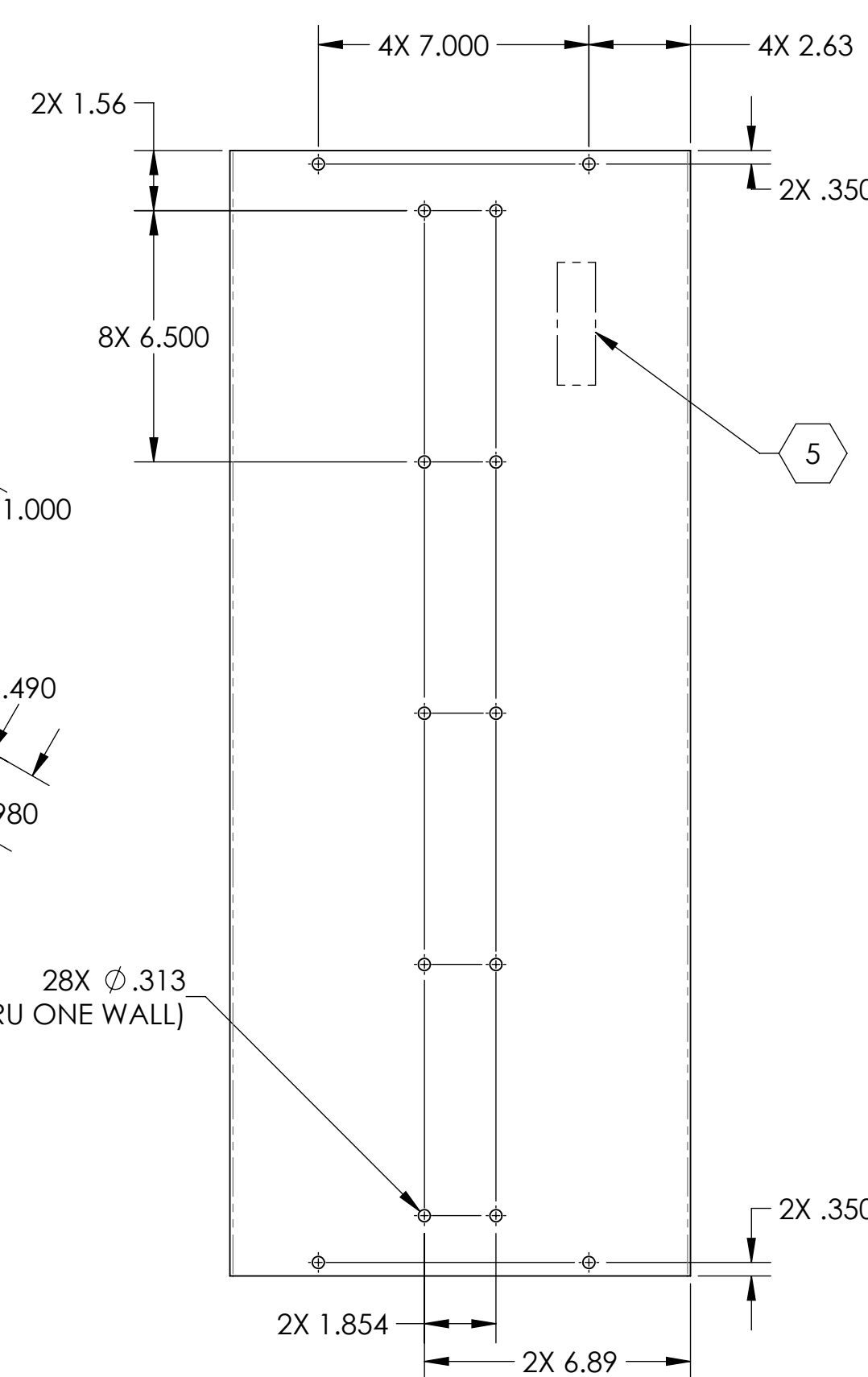
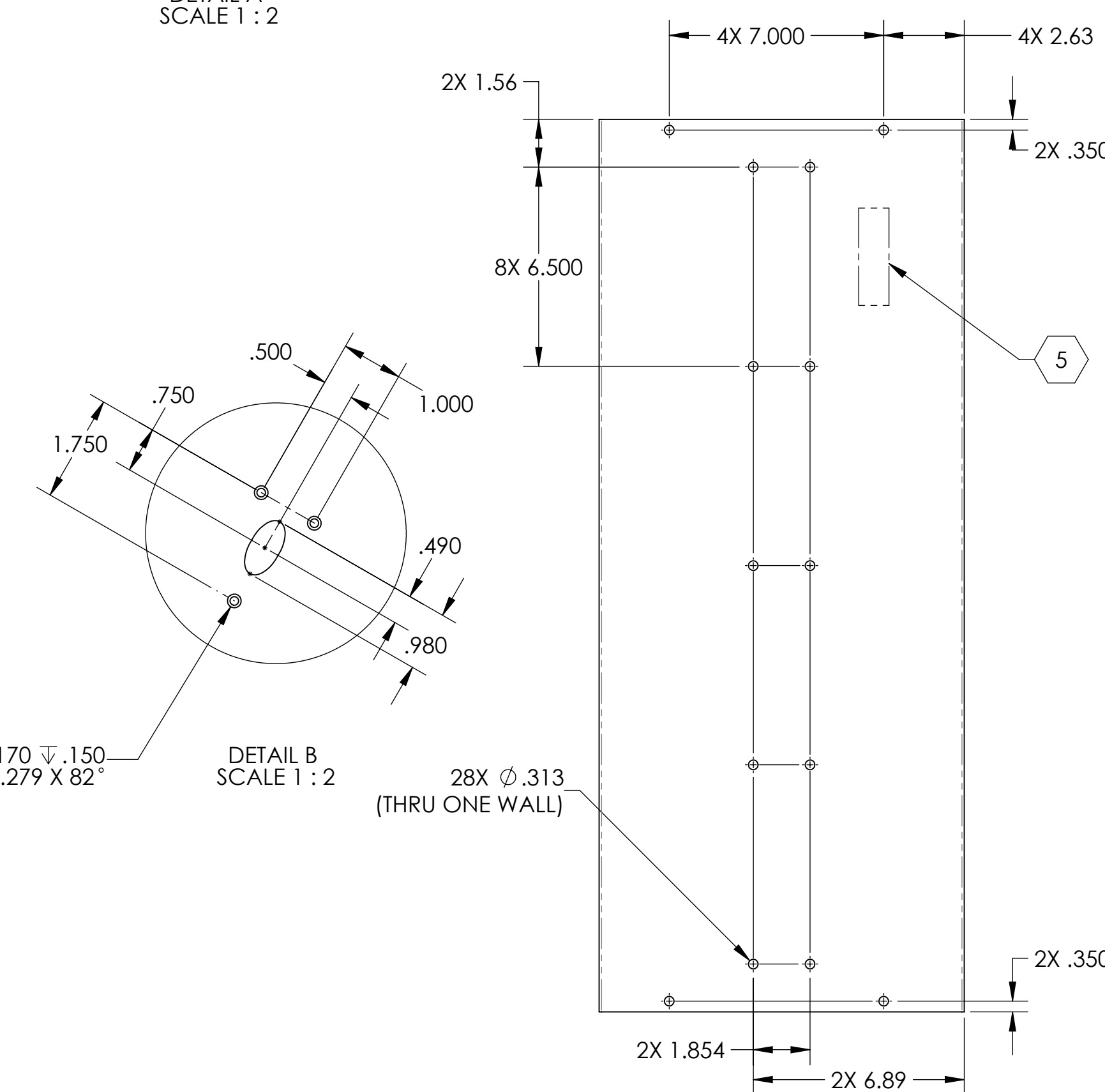
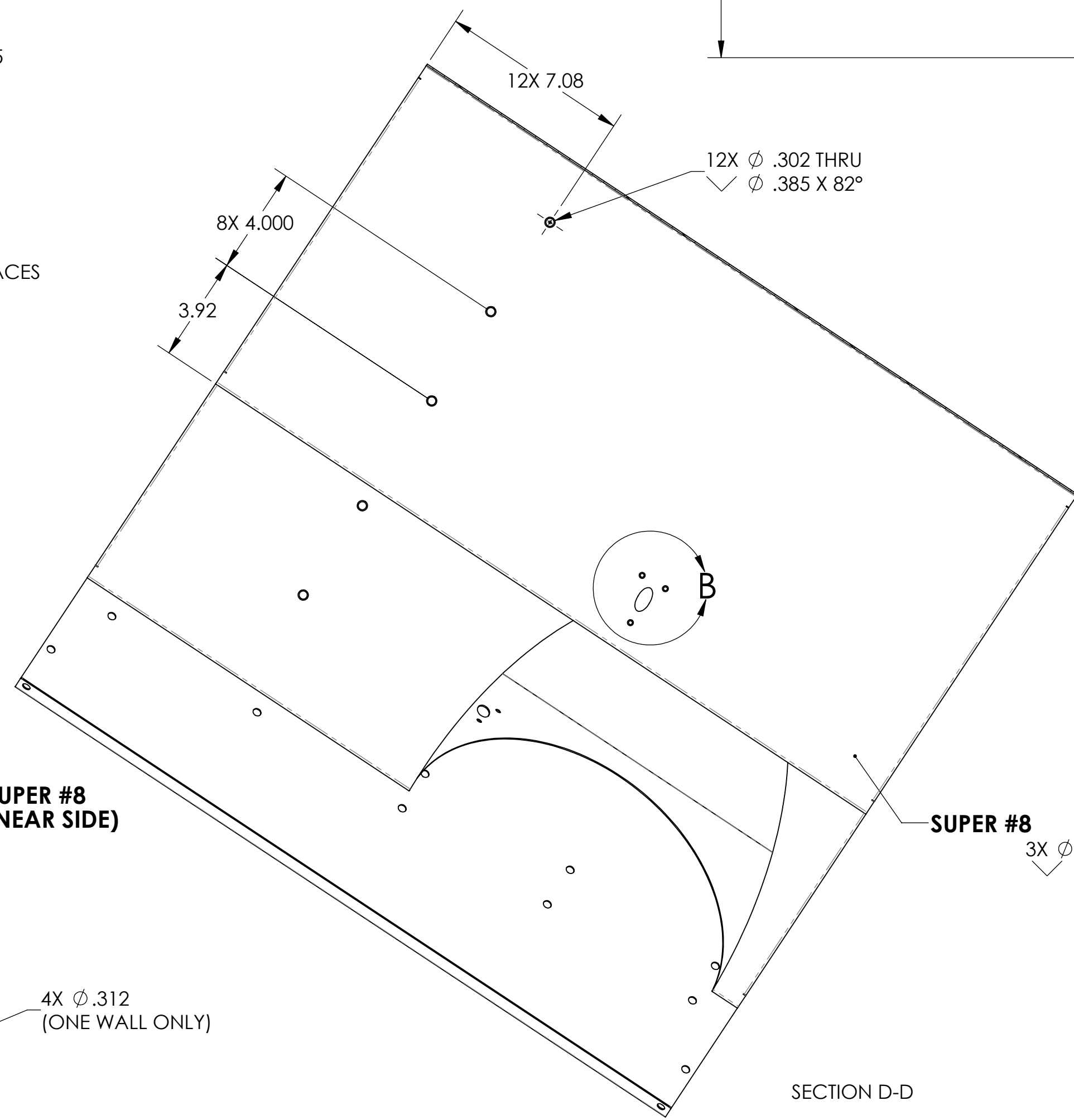
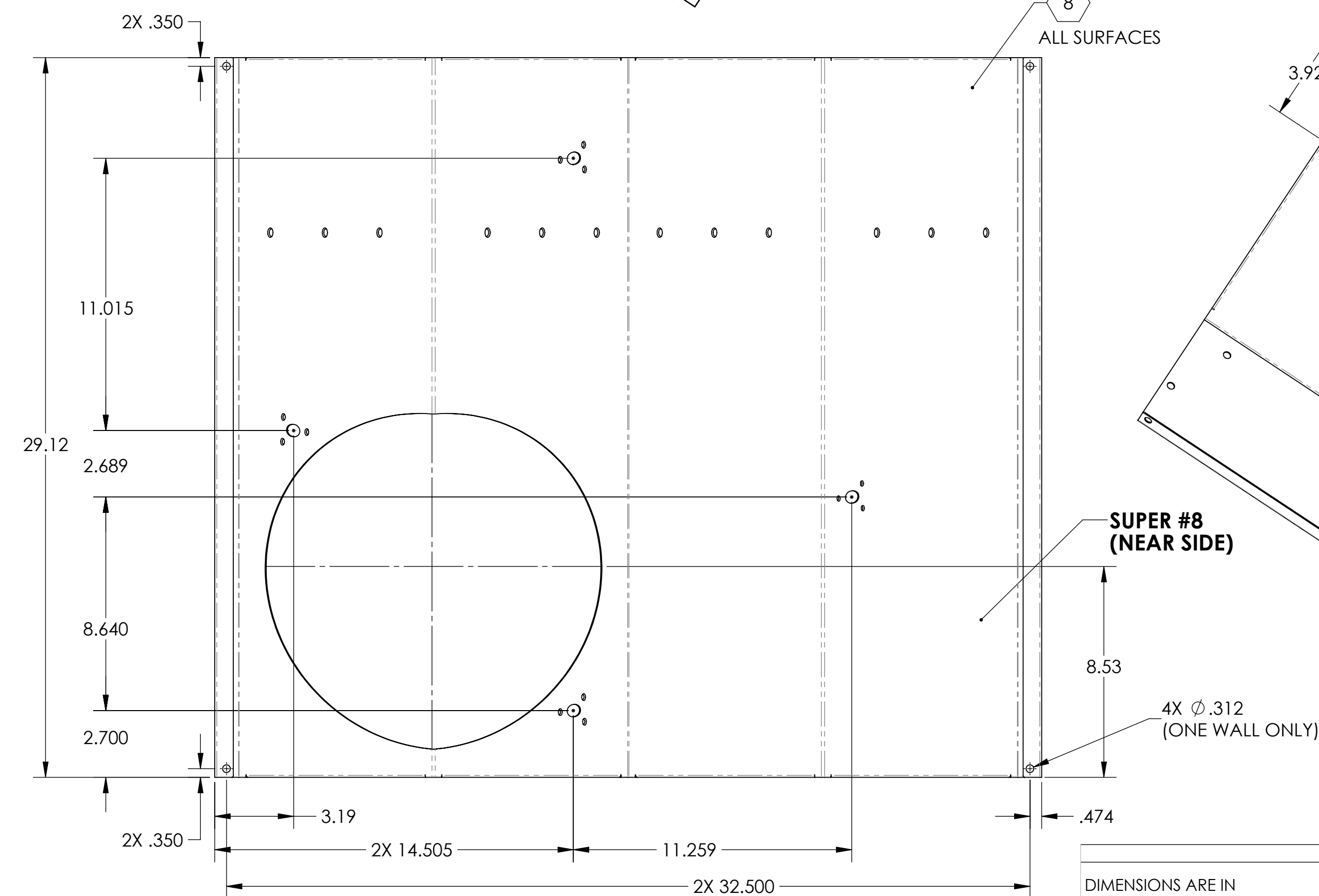
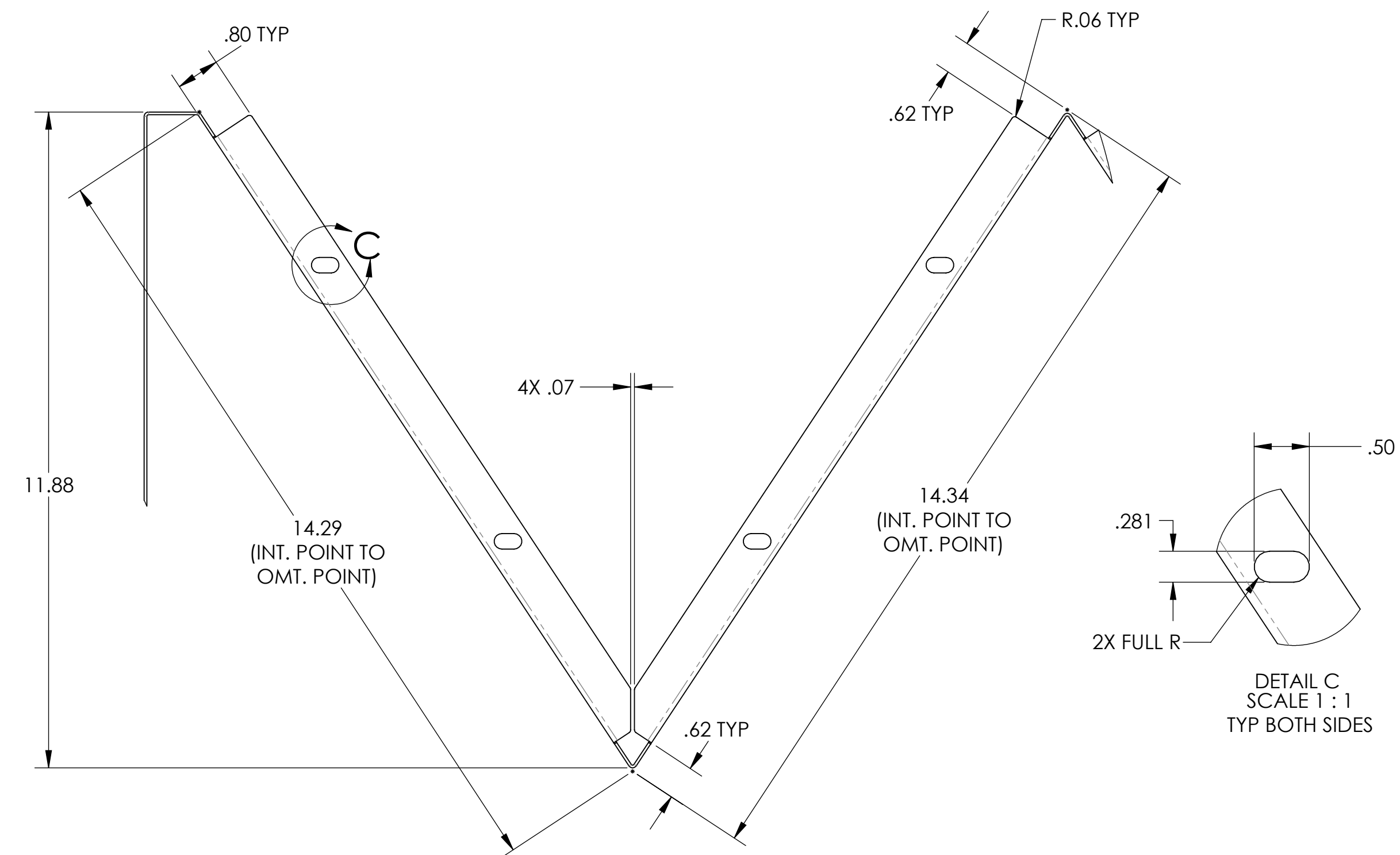
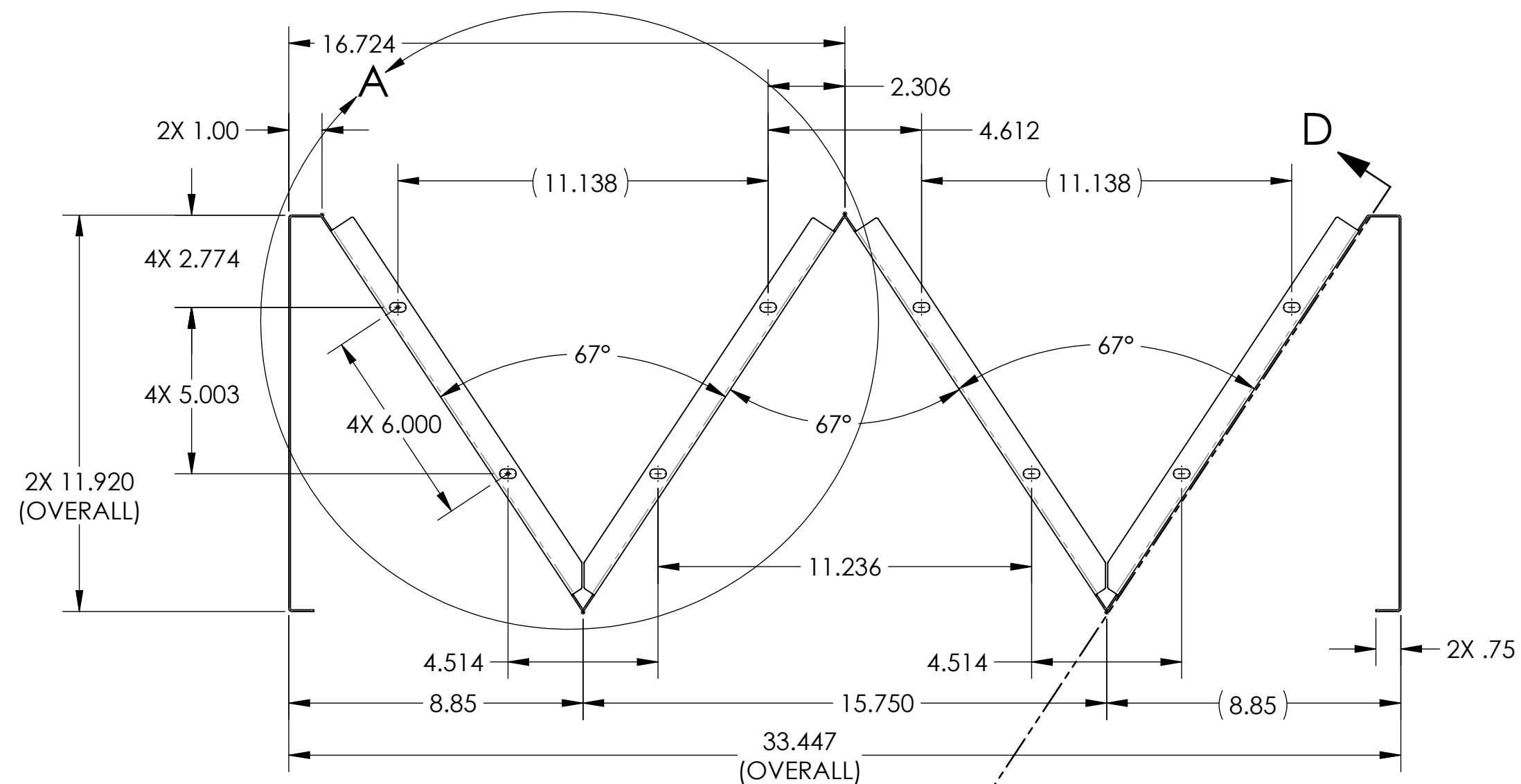

<p>NOTES AND TOLERANCES: (UNLESS OTHERWISE SPECIFIED)</p> <p>1. INTERPRET DRAWING PER ASME Y14.5-1994.                  2. REMOVE ALL SHARP EDGES .005-.015. FOR MACHINED PARTS. ROUND ALL EDGES APPROXIMATELY R.02 FOR SHEET METAL PARTS.                  3. DO NOT SCALE FROM DRAWING.                  4. ALL MACHINING FLUIDS MUST BE FULLY SYNTHETIC, FULLY WATER SOLUBLE AND FREE OF SULFUR, SILICONE, AND CHLORINE.</p>		<p><b>LIGO</b> CALIFORNIA INSTITUTE OF TECHNOLOGY                  MASSACHUSETTS INSTITUTE OF TECHNOLOGY</p>		<p>PART NAME  <b>ACB 1 HOLE LEFT QPD SKIN (w pd)</b></p>	
<p>DIMENSIONS ARE IN</p> <p>TOLERANCES:                  .XX ± .02                  .XXX ± .010</p> <p>ANGULAR ± .5°</p>		<p>SYSTEM  <b>ADVANCED LIGO</b></p>		<p>SUB-SYSTEM  <b>AOS</b></p>	
<p>MATERIAL  <b>18 GAUGE, 304 SSSL</b></p>		<p>FINISH  <b>SUPER #8 (8)</b></p>		<p>NEXT ASSY  <b>D1200314</b></p>	
<p>DESIGNER                  N.Nguyen</p>		<p>CHECKER                  M.RUIZ</p>		<p>DATE                  20 Dec 2010</p>	
<p>SCALE: 1:4</p>		<p>PROJECTION:</p>		<p>SIZE DWG. NO.  <b>D 1200313</b></p>	
<p>REVISION                  v3</p>		<p>SHEET 1 OF 3</p>		<p>APPROVAL</p>	

D:\200313\_Audi\GO\_AOS\_SIC\_ACB\_BOX\_LEFT\_HOLE\_SKIN (w pd).PART FROM REV. X-006. DRAWING FROM REV. X-012

8 7 6 5 4 3 2 1

H G F E D C B A

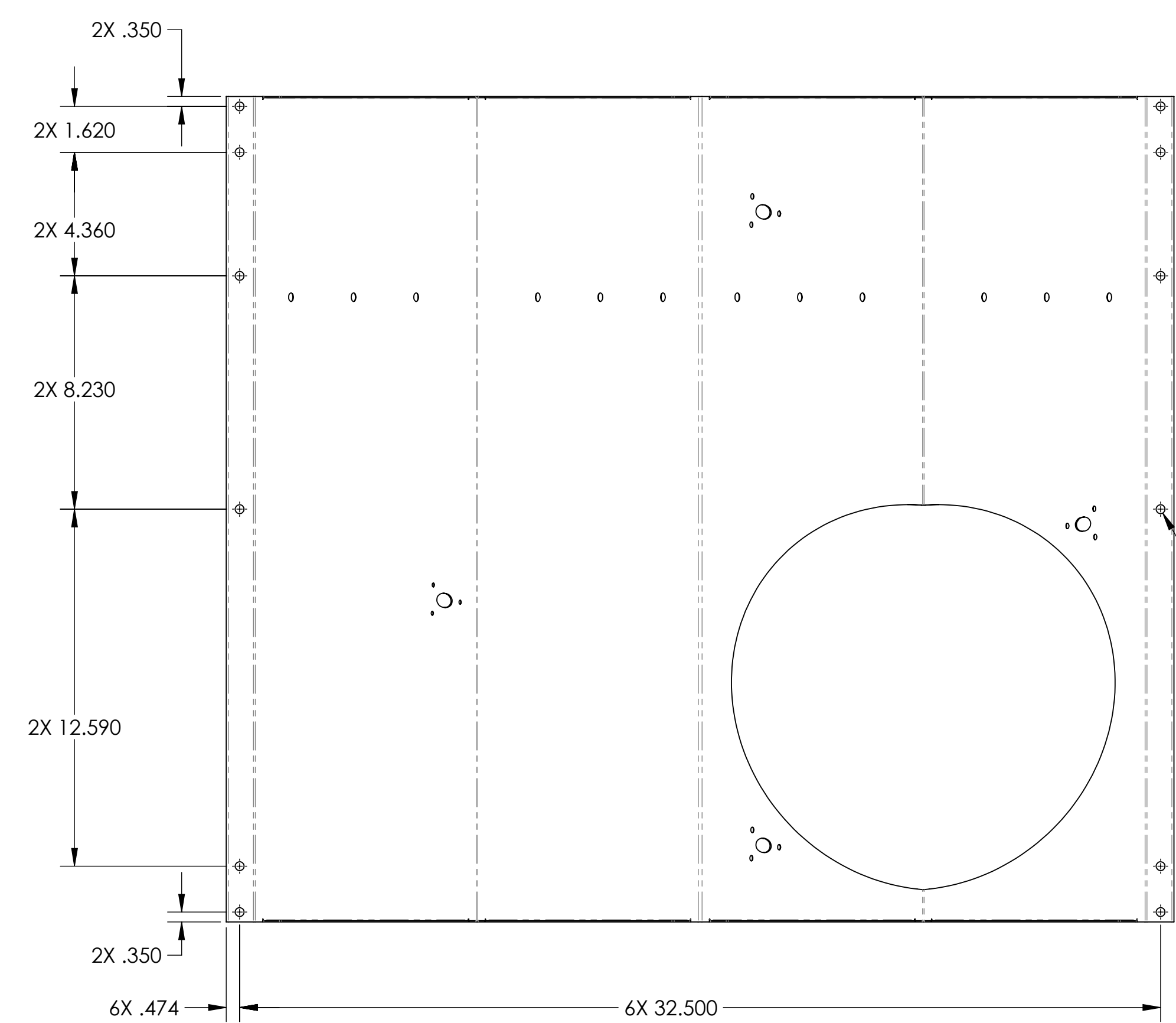
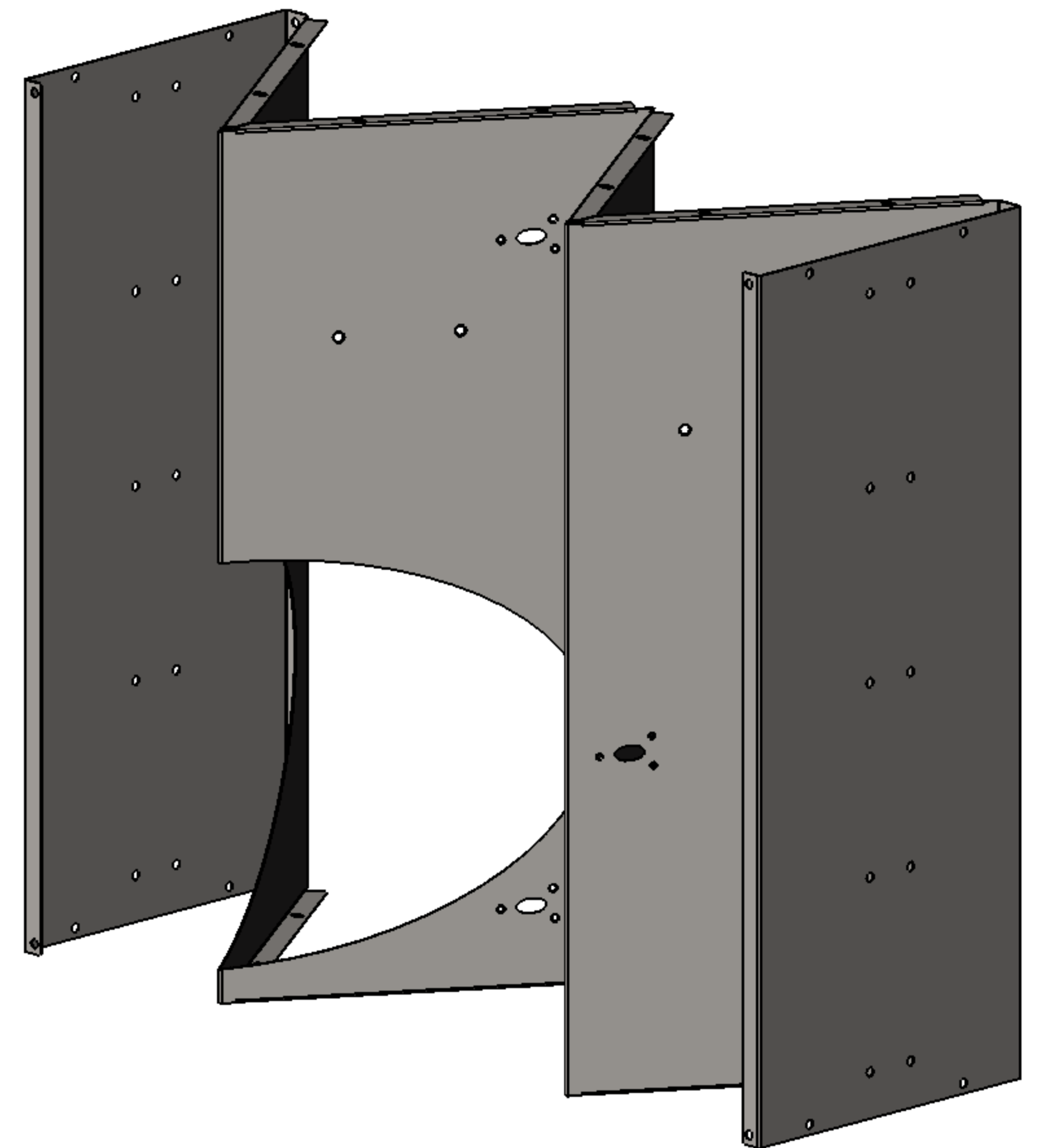
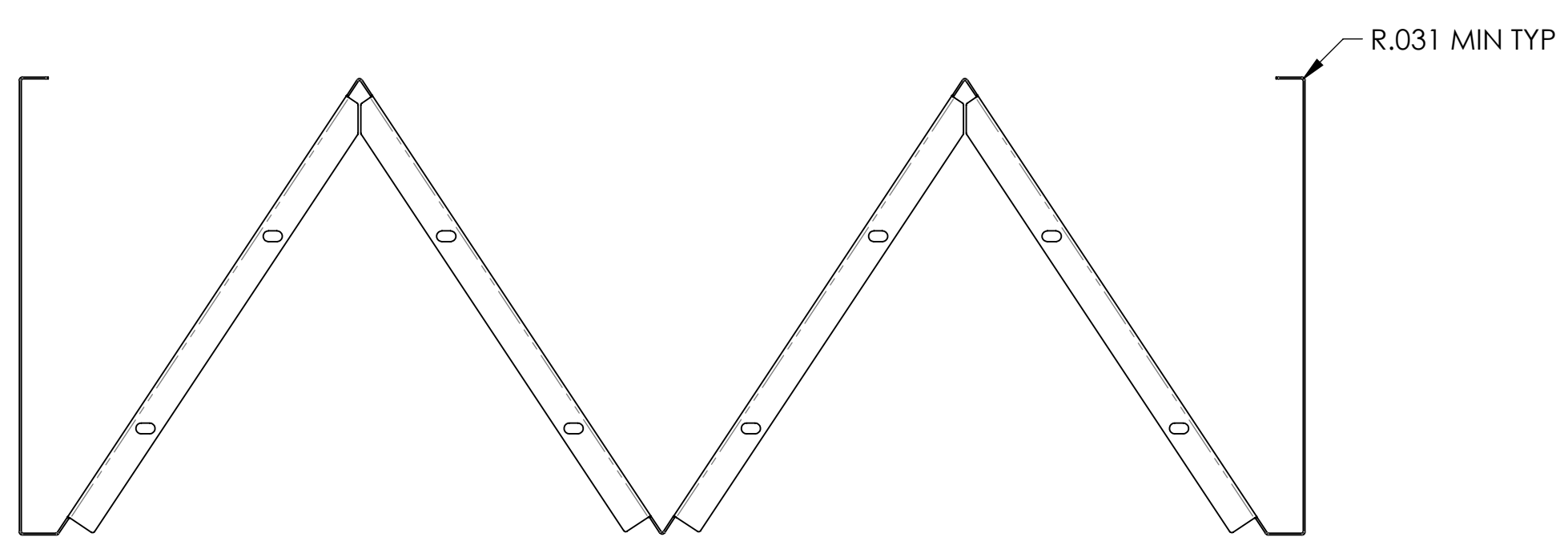
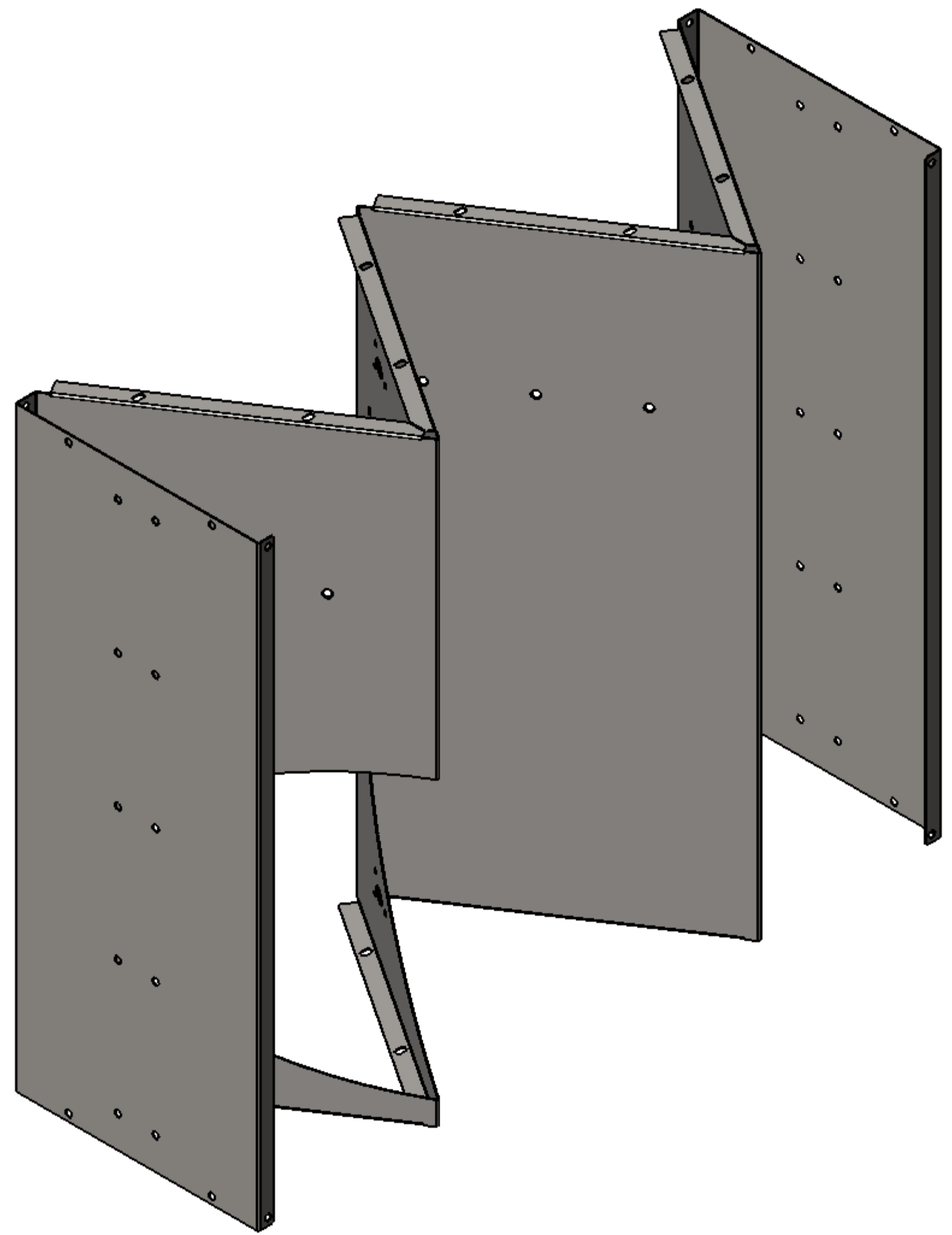

12X  $\phi$ .31  
(THRU ONE WALL)

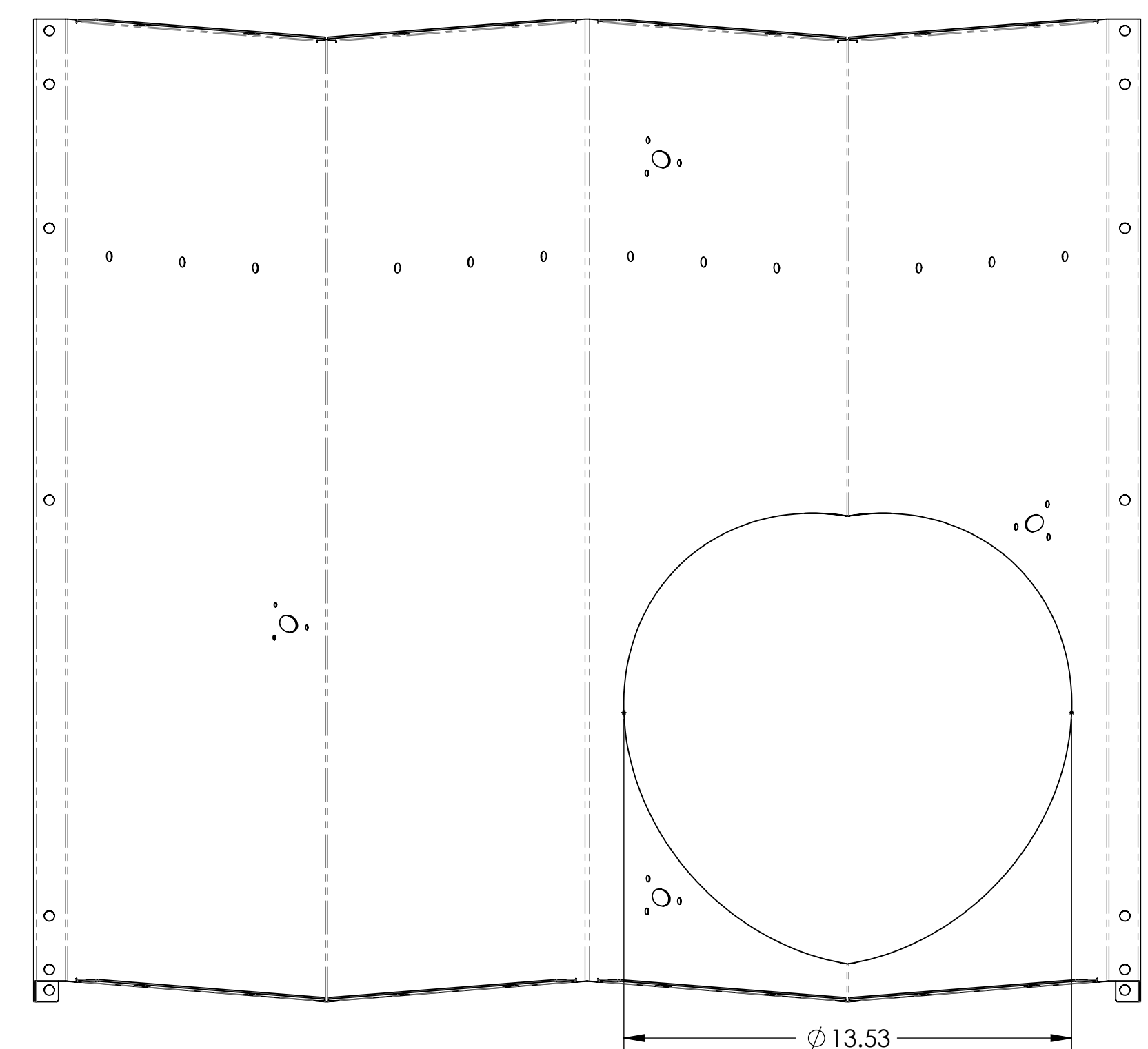

<b>LIGO</b> CALIFORNIA INSTITUTE OF TECHNOLOGY MASSACHUSETTS INSTITUTE OF TECHNOLOGY	
SIZE DWG. NO.	REV.
<b>D</b> <b>D1200313</b>	<b>v3</b>
SCALE: 1:4	PROJECTION:  SHEET 2 OF 3

D1200313\_AduIGO\_ACS\_S1C\_ACB\_BOX\_LEFT\_THOLE\_SKIN (w/PD) PART PDM\_REV: X:00; DRAWING PDM\_REV: X:02

8 7 6 5 4 3 2 1

8 7 6 5 4 3 2 1

H G F E D C B A

SUPER #8  
FAR SIDE

APERTURE

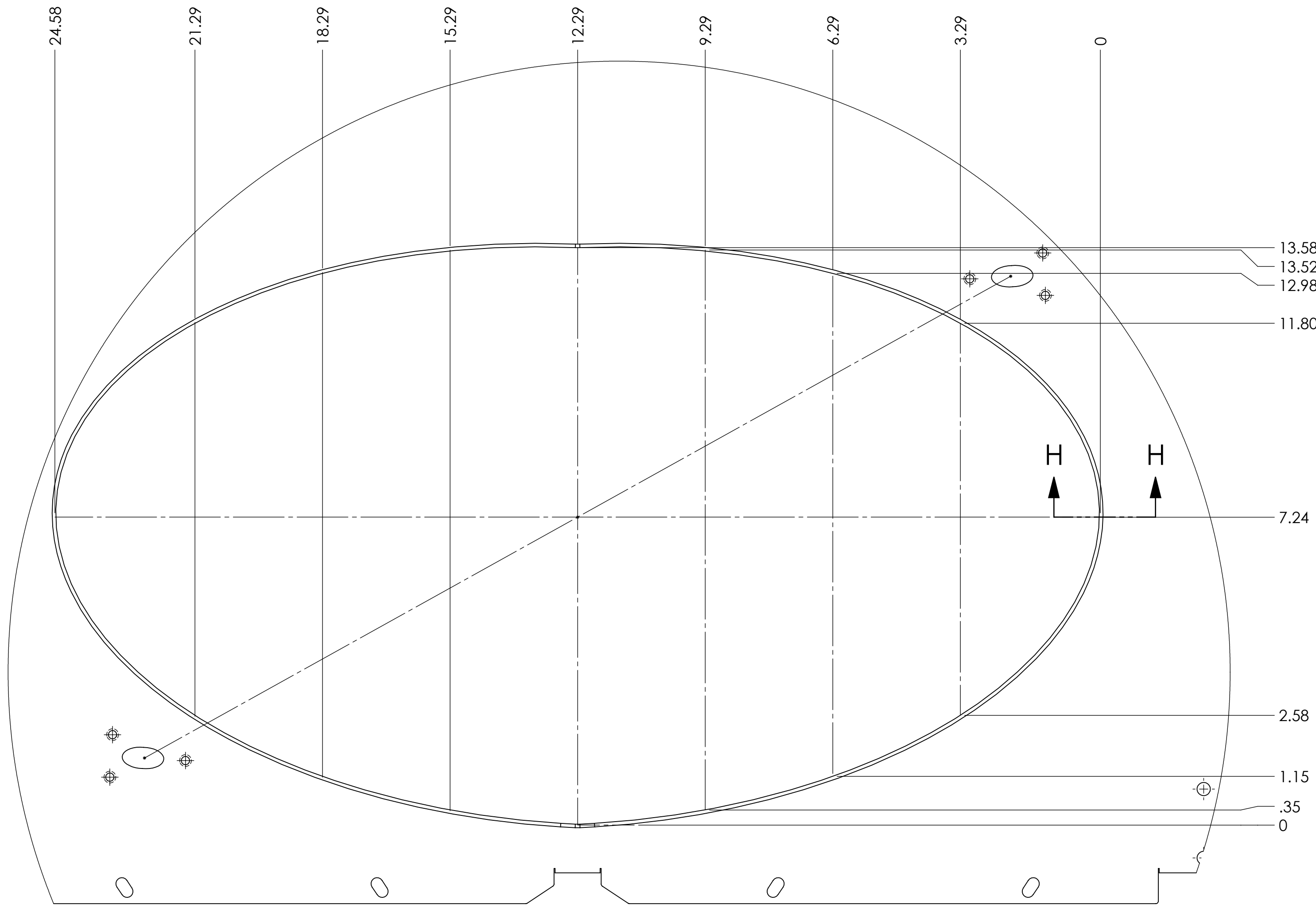
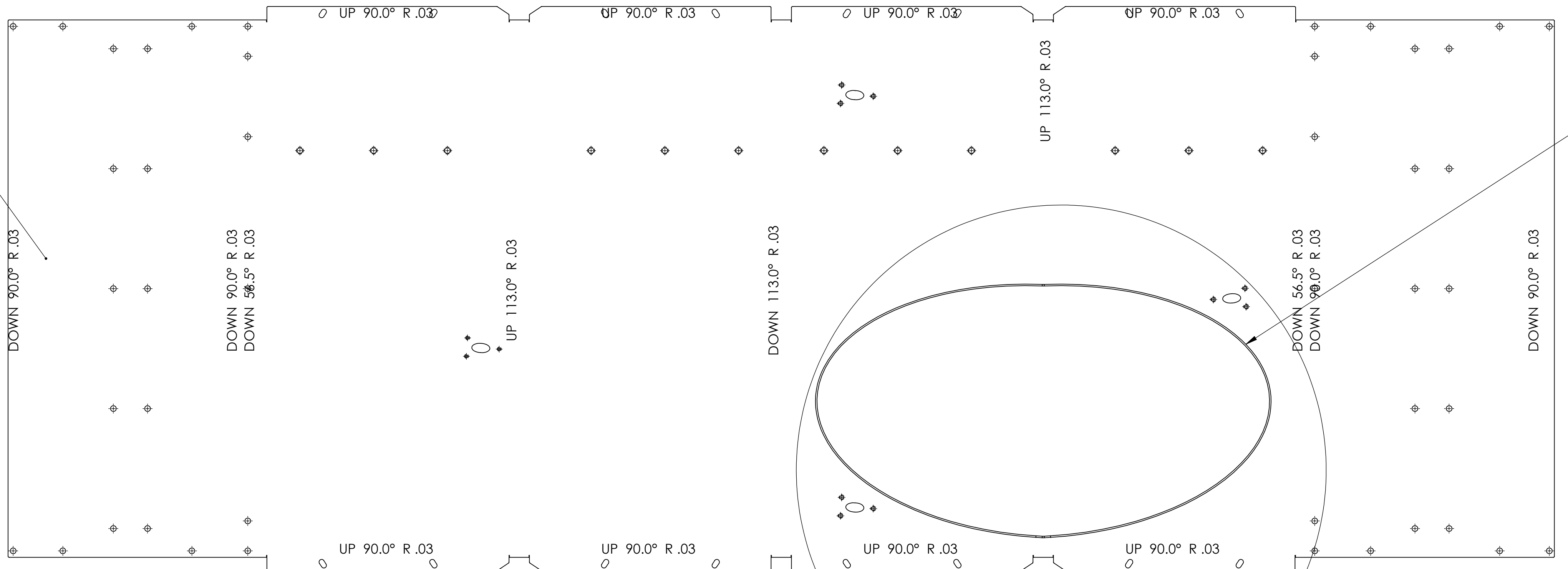

DETAIL F  
SCALE 1 : 2

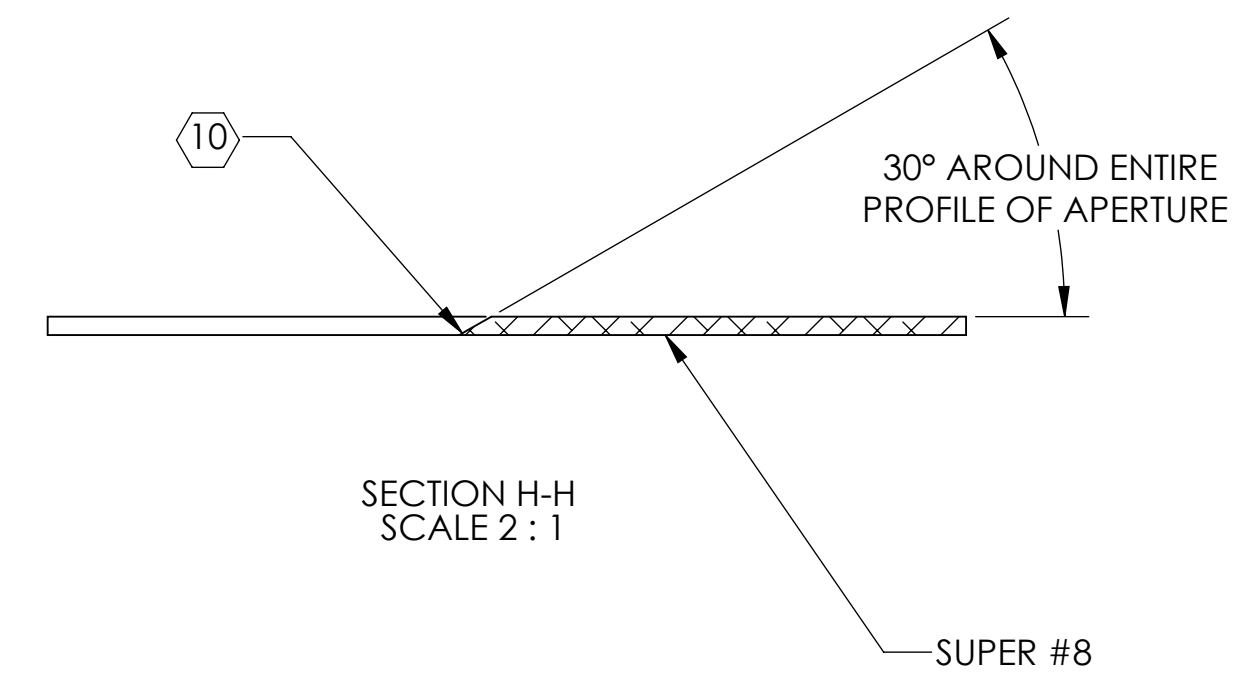

**LIGO** CALIFORNIA INSTITUTE OF TECHNOLOGY  
MASSACHUSETTS INSTITUTE OF TECHNOLOGY

SIZE	DWG. NO.	REV.
D	D1200313	v3
SCALE: 1:4	PROJECTION:	SHEET 3 OF 3

D:\200313\_AduLIGO\_ACS\_SLC\_ACB\_BOX\_LEFT\_1\_HOLE\_SKIN\_V(PD).PART.PDM.REV.X-006.DRAWING.PDM.REV.X-012