

REVISIONS				
ZONE	REV.	DESCRIPTION	DATE	APPROVED
	B	New sheet format	2/25/2011	K Singh

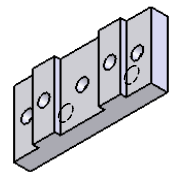
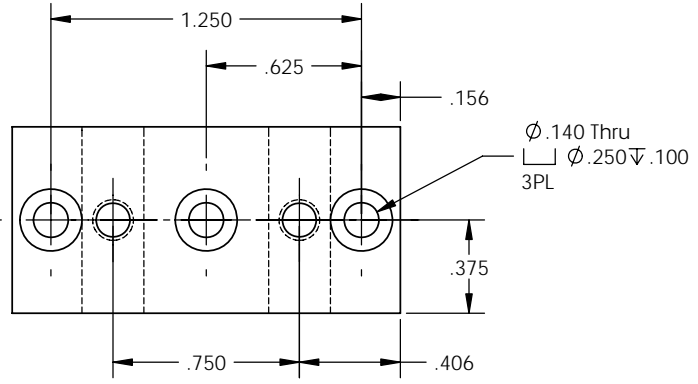
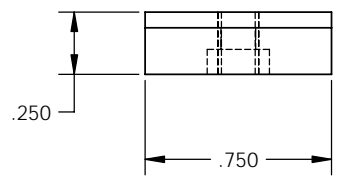
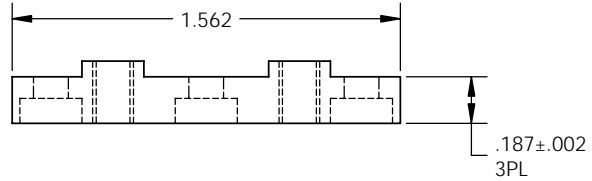
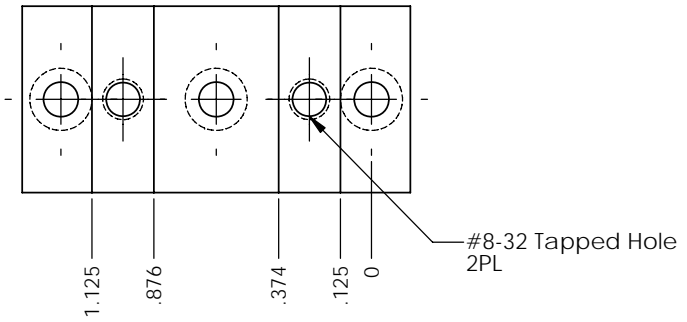

Notes:
 Material: 1018 C.R.S.
 Finish: Electroless Nickel plate per AMS-C-26074 -CLASS 2, GRADE C
 Surface finish 32 Min.
 Break all edges R.02
 All dimensions are after plating.

Unless otherwise specified
 All dimensions are in inches.
 Tolerances: Decimal: x.x ±.05, x.xx ±.01
 x.xxx ±.003
 Angular: x.x±1°

Bracket Custom Bottom Plate

LIGO CALIFORNIA INSTITUTE OF TECHNOLOGY
 MASSACHUSETTS INSTITUTE OF TECHNOLOGY

SIZE	DWG. NO.	REV.
B	5099-217-4	B
SCALE: 3:1	PROJECTION	SHEET 1 OF 1

Draw2, PART PDM REV: , DRAWING PDM REV: