

**LASER INTERFEROMETER GRAVITATIONAL WAVE OBSERVATORY**  
**-LIGO-**  
CALIFORNIA INSTITUTE OF TECHNOLOGY  
MASACHUSETTS INSTITUTE OF TECHNOLOGY

<b>LIGO- E1101021-v2</b>	4/25/12
<b>AOS SLC ITM Elliptical Baffle Installation Procedure</b>	
Michael Smith, Lisa C. Austin	

**LIGO Hanford Observatory**  
**P.O. Box 1970; Mail Stop S9-02**  
**Richland, WA 99352**  
Phone (509) 37208106  
Fax (509) 372-8137  
E-mail: [info@ligo.caltech.edu](mailto:info@ligo.caltech.edu)

**LIGO Livingston Observatory**  
**19100 LIGO Lane**  
**Livingston, LA 70754**  
Phone (225) 686-3100  
Fax (225) 686-7189  
E-mail: [info@ligo.caltech.edu](mailto:info@ligo.caltech.edu)

**California Institute of Technology**  
**LIGO – MS 100-36**  
**Pasadena, CA 91125**  
Phone (626) 395-2129  
Fax (626) 304-9834  
E-mail: [info@ligo.caltech.edu](mailto:info@ligo.caltech.edu)

**Massachusetts Institute of Technology**  
**LIGO – MS NW22-295**  
**Cambridge, MA 01239**  
Phone (617) 253-4824  
Fax (617) 253-7014  
E-mail: [info@ligo.mit.edu](mailto:info@ligo.mit.edu)

**CHANGE LOG**

<b>Date, version</b>	<b>Summary of Changes</b>
2012-04-26 V2	<ul style="list-style-type: none"><li>• Corrected Cal Tech Mail Stop address</li><li>• Pasted sections from the arm cavity baffle installation procedure. The procedure is similar and needs to be modified to reflect the requirements of the ITM elliptical baffle.</li></ul>
	<ul style="list-style-type: none"><li>•</li></ul>

Table of Contents

<b>1</b>	<b>SCOPE .....</b>	<b>5</b>
1.1	ITM Elliptical Baffle.....	5
<b>2</b>	<b>INSTALLATION PREPARATION .....</b>	<b>9</b>
2.1	Installation Set-up .....	9
<b>3</b>	<b>INSTALLATION PROCEDURE.....</b>	<b>12</b>
3.1	<b>Assembly of ACB Installation Stand .....</b>	<b>12</b>
3.2	<b>Insertion of ACB Suspension Assembly into ACB Installation Stand .....</b>	<b>12</b>
3.3	Arm Cavity Baffle Suspension Assembly (D1001011) Installation onto Test Stand.....	14
3.4	Arm Cavity Baffle Box Assembly (D1000977) Installation onto Test Stand.....	19
3.5	Initial Baffle Balance.....	23
<b>4</b>	<b>REMOVAL FROM TEST STAND .....</b>	<b>26</b>
4.1	Removal Preparation .....	26
4.2	Baffle Box Removal.....	27
4.3	Suspension Assembly Removal .....	28
<b>5</b>	<b>INSTALLATION PREPARATION .....</b>	<b>31</b>
5.1	Requirements for Installation .....	31
5.2	Assemblies required for Installation.....	31
5.3	Other Vacuum Parts required for Installation.....	31
5.4	Other Non-Vacuum Parts required for Installation .....	32
5.5	Tools required for Installation .....	32
<b>6</b>	<b>INSTALLATION PROCEDURE.....</b>	<b>34</b>
6.1	Installation Set-up .....	34
6.2	Arm Cavity Baffle Suspension Assembly Installation (D1001011) .....	37
6.3	Arm Cavity Baffle Box Assembly Installation (D1000977).....	45

6.4 Baffle Alignment.....53

**7 REMOVAL OF FIXTURES AND TOOLING .....57**

7.1 After Installation .....57

7.2 After Alignment.....57

**Table of Tables**

*No table of figures entries found.*

**Table of Figures**

*Figure 1: ITM Elliptical Baffle..... 5*

*Figure 2: Baffle & Beam Dump Suspension, Mounted to ISI Stage 0..... 6*

*Figure 3: Lift Fixture for Lifting Suspension Assy to the ISI Stage 0 Prior to Clamping .. 7*

## 1 Scope

This document describes the assembly and installation procedures for the ITM Elliptical Baffle.

### 1.1 ITM Elliptical Baffle

The ITM Elliptical baffle assembly is shown in Figure 1.

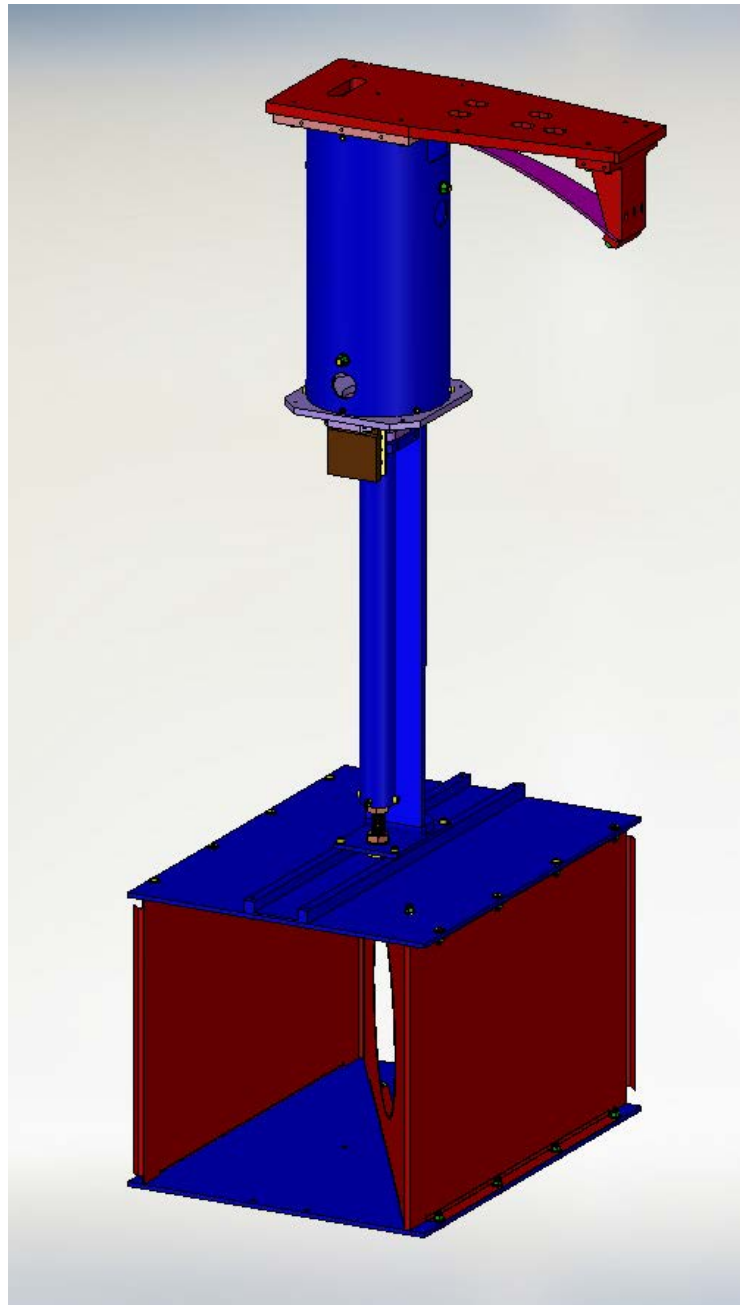

**Figure 1: ITM Elliptical Baffle**

The 44.3 lb ITM Elliptical Baffle is suspended from the ISI Stage 0 inside the BSC, as shown in Figure 2.

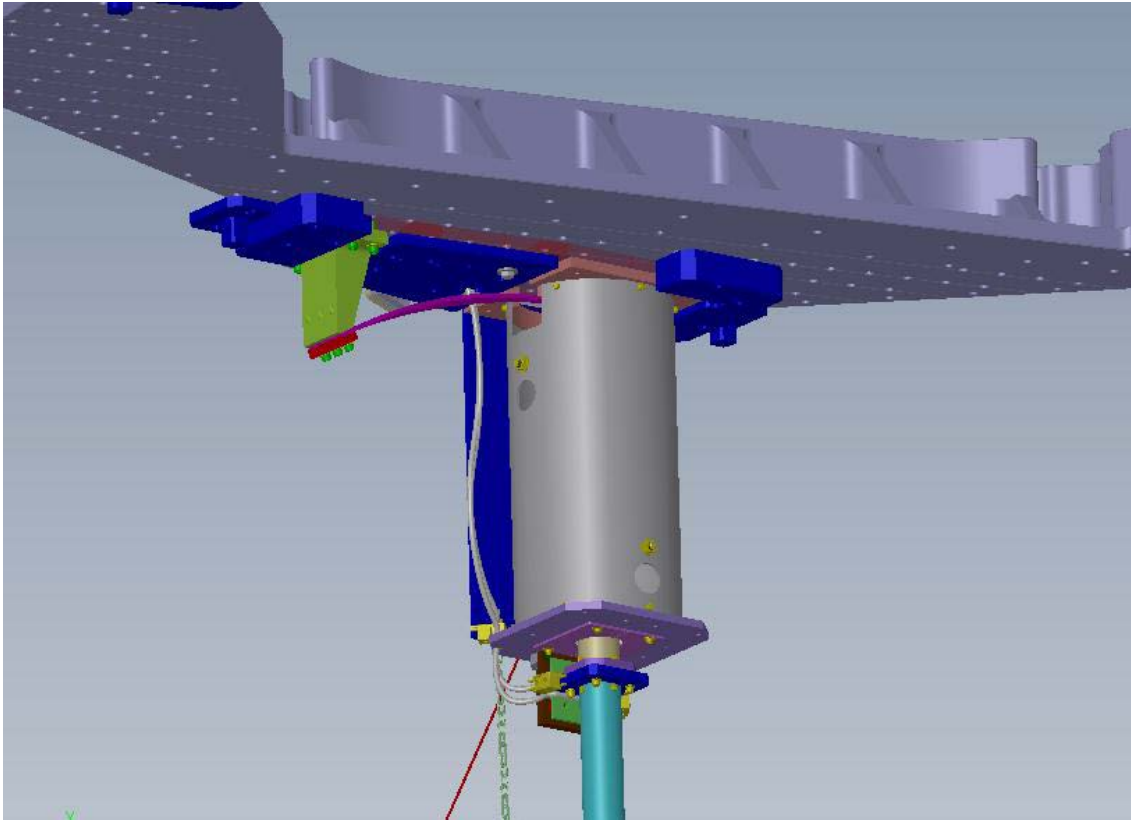

**Figure 2: Baffle & Beam Dump Suspension, Mounted to ISI Stage 0**

- 1 Prior to installing the suspension assembly, it will be assembled on a laboratory bench.  
The vertical blade spring is attached to its mounting bracket and preloaded with approximately 45 lbs balance weight during the bench assembly of the suspension structure (SUS).
- 2 The 49 lb assembled SUS is then placed on top of the lift fixture, as shown in Figure 3, and lifted into place against the ISI Stage 0 by adjusting the telescoping leg length and by adjusting the height of the expanding scissors lift mechanism.

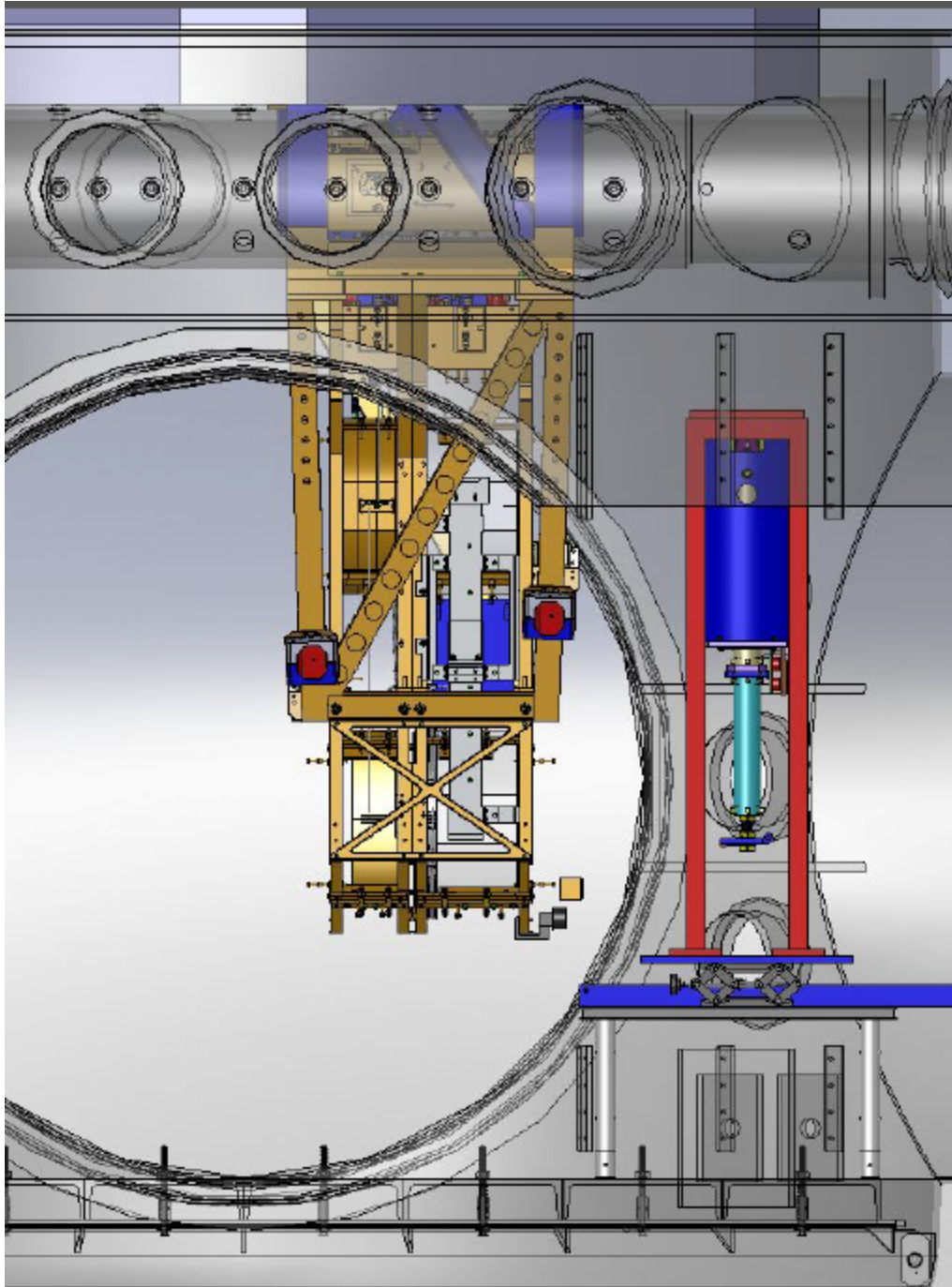

**Figure 3: Lift Fixture for Lifting Suspension Assy to the ISI Stage 0 Prior to Clamping**

- 3 The baffle suspension interface plate base will be held and positioned approximately in the final position by the temporary alignment clamps attached to Stage 0.

- 4 While the baffle suspension is held in place by the clamps, the vertical lift fixture will be removed.
- 5 The box structure of the baffle will be brought into the chamber and placed on top of the lift table, which will then be raised to bring the box structure in position to mount it to the bolt at the bottom of the suspension down tube.
- 6 While the baffle lateral position is being surveyed by an alignment theodolite, the baffle suspension will be slid laterally within the temporary alignment clamps until the baffle is positioned accurately on the beam center line as indicated with the theodolite. Then the interface plate will be rigidly clamped with appropriate dog-clamps to the Stage 0, using a torque wrench to tighten the dog-clamp bolts. The vertical alignment of the baffle is established by mechanical measurement from the bottom surface of the Stage 0



**NOTE:**  
**THE FOLLOWING SECTIONS ARE PASTED FROM THE ARM CAVITY BAFFLE INSTALLATION PROCEDURE. THE PROCEDURE IS SIMILAR AND NEEDS TO BE MODIFIED TO REFLECT THE REQUIREMENTS OF THE ITM ELLIPTICAL BAFFLE!!**

## **Section 1 – ITM Elliptical Baffle installation onto Test Stand**

### **2 Installation Preparation**

#### **2.1 Installation Set-up**

##### **2.1.1 *Items required for Installation Set-up, in order of use:***

- 1 – lifting Table (D1002192)
- 3 – tall step stands for reaching to top of Test Stand
- 2 - “Wedge Lift, Baffle, Suspension Table” (D1101952)
- 1 - “Arm Cavity Baffle Box Assembly” (D1000977)
- 1 - “Suspension Lift Table” (D1102061), with “Table, Secondary, Suspension” (D1101962) and four “Table Dog Clamps” (D1001376-2) attached
- 2 - SHCS (1/4-20 x .62”)
- 2 - 3/16” Hex Allen tool of 1/4-20 SHCS
- 2 - 5/16” Hex Allen tool of 3/8-16 SHCS
- 2 - Plain Grip Looped T-Handle Hex Key 3/16” Hex
- 12 – dog clamps for mounting to the Test Stand

##### **2.1.2 *Set-up “Suspension Lift Table” (D1102061), with “Table, Secondary, Suspension” (D1101962) and four “Table Dog Clamps” (D1001376-2) attached, under Test Stand on top of the cranked lifting table (D1002192)***

*that will allow the Suspension Stand to be mated to the Test Stand ceiling. The Suspension Lift Table weighs about 62 lbs. and the Secondary Table weighs about 20 lbs. Note: orient the crank opposite to the “ACB Bend Fixture Holder Assembly” (D1102325) of the Suspension Assembly.*

Note: the Table, Secondary, Suspension” (D1101962) needs to be modified so that the Installation Stand can be centered on the lifting table.

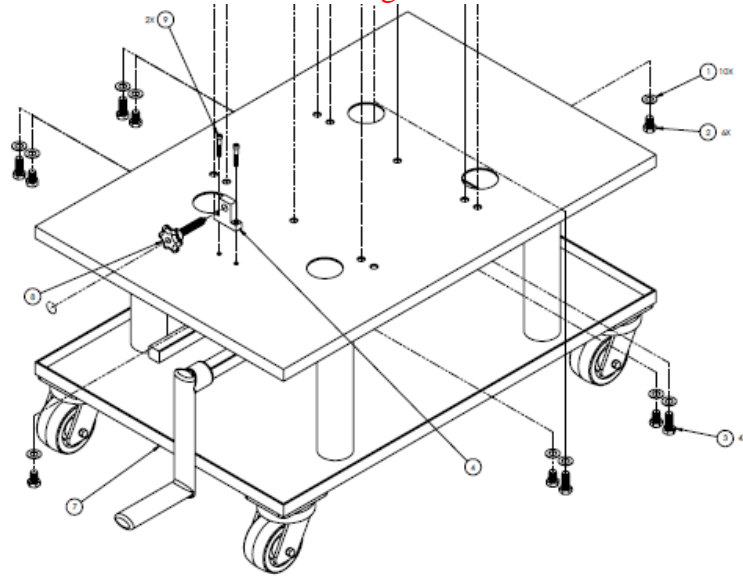



2.1.3 Adjust position of *lifting Table (D1002192)* to sit directly below Baffle attachment area on Test Stand.

2.1.4 Verify Jacks are in completely collapsed state.

### 3 Installation Procedure

#### 3.1 Assembly of ACB Installation Stand

Need a procedure!

#### 3.2 Insertion of ACB Suspension Assembly into ACB Installation Stand

- 1 - Position the ACB\_Installation Stand” (D1101957) on the clean room floor on top of aluminum foil
- 2 - Remove the upper clamp D1102062 - save the hardware for later use
- 3 - Remove both side beams D1102026 - save the hardware for later use
- 4 - Place ACB\_Stage Zero Narrow-Dog Clamp, End (D1101613) on top of stand at the side nearest the three horizontal clearance holes in the side beam
- 5 - Place ACB\_Stage Zero Narrow Guide Block (D1101595) on top of stand on the other side
- 6 – Verify that the short transport bracket D1101285 and the long transport bracket D1101578 are attached
- 7 - Two people lift the Arm Cavity Baffle Suspension Assembly (D1001011), while a 3<sup>rd</sup> person holds the stand, and place the Stage Zero Interface plate on top of the stand between the Narrow-Dog Clamp and the Narrow Guide Block with the wide end of the interface plate next to the Narrow-Dog Clamp.



7 - Replace and fasten the upper clamp D1102062 and the side beam D1102026 with the saved hardware

### 3.3 Arm Cavity Baffle Suspension Assembly (D1001011) Installation onto Test Stand

#### 3.3.1 Items required for Arm Cavity Baffle Suspension Assembly Installation, in order of use:

1 - “ACB\_Installation Stand” (D1101957), with “Arm Cavity Baffle Suspension Assembly” (D1001011), “ACB\_Stage Zero Narrow\_Guide Block” (D1101595) and “ACB\_Stage Zero Narrow-Dog Clamp, End” (D1101613) installed.

NOTE: The Arm Cavity Baffle Suspension Assembly must have the following tooling attached: “ACB Bend Fixture Holder Assembly” (D1102325) with “Bend Fix Plate Handle” (D1102193-02) removed and attached to the Suspension Stand with wire, “Transport, Locking, ACB” (D1101285), and “Height, Adjustment, ACB” (D1101578).

NOTE: “ACB\_Stage Zero Interface Fixture Mover” (D1101700) must NOT be installed.

- 2 - 3/16” Hex Allen tool of 1/4-20 SHCS
- 2 - Plain Grip Looped T-Handle Hex Key 3/16” Hex
- 2 - 5/16” Hex Allen tool of 3/8-16 SHCS
- 5 - SHCS (3/8-16 x 2 1/2")
- 5 - 3/8” washers
- 4 - SHCS (3/8-16 x 2 1/2")
- 4 - 3/8” washers
- 2 - 3/16” Hex Allen tool of 1/4-20 SHCS
- 3 – tall step stands (class B) to reach top of test stand table
- 4 – interface mounting D1001700, need 12 dog clamps 3/8/-24 lower design ?

**3.3.2 CHECK THE LEVEL OF THE MOUNTING SURFACE OF THE TEST STAND! It is PARAMOUNT that this surface be level to within 0.14 deg. This will ensure that the upper tube can be positioned after balancing to within 1 mm of the centerline position of the earthquake stop flange opening and allow a range of motion > 2 mm of the upper tube.**

3.3.3 Two people carry the “Arm Cavity Baffle Suspension Assembly” (D1001011), which is secured in the expandable “Installation Stand” (D1101957) in its collapsed and locked configuration, and carefully place it on top of the “Table, Secondary, Suspension” (D1101962); the **orientation on the table should match the orientation of the ACB Box when it is installed later**. Total weight is about 100 lbs. There are handles on the Installation Stand for lifting and carrying.





**NOTE: Two people remain on each side of the “Suspension Lift Assembly” (D1101953).**

3.3.4 *Secure Installation Stand to Secondary Table with the four Table Dog Clamps attached to the Table.*

Note: We need to tap new holes on the Secondary Table so that the Installation Stand can be positioned at the middle of the Secondary Table for ease of access to the two lifting people.

3.3.5 Loosen Table Dog Clamps that secure the Installation Stand and align to placement location on Test Stand.

3.3.6 Tighten Table Dog Clamps to secure Installation Stand.

3.3.7 With Installation Stand secured, remove four SHCS and “Upper Clamp” (D1102062) from top of Installation Stand. Remove parts and set aside.

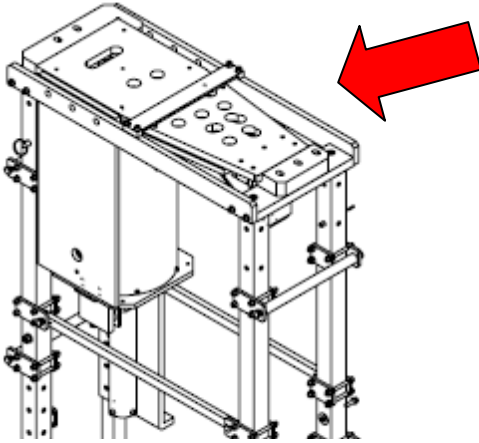

3.3.8 Remove four 1/4-20 SHCS and “SIDE BEAM” (D1102026) from Installation Stand on both sides of the Installation Stand. Remove and set aside.

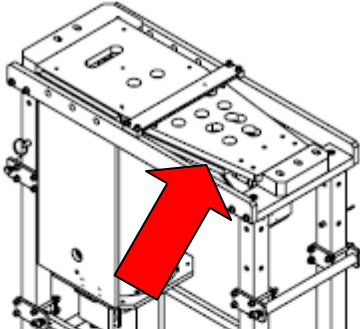

3.3.9 Crank the lifting table to the lowest position.

3.3.10 Two people grab the lifting bars on each side of the **Installation Stand** and a 3<sup>rd</sup> person removes the locking pins that secure the telescoping legs. Raise the installation stand to the nearest telescoping leg locking hole that brings the installation stand closest to the Test Stand mounting surface. Insert the locking pins and secure the telescoping legs.

Note: we need a better platform for the two lifting people to stand on during the lifting.

3.3.11 Slowly crank the lifting Table (D1002192) upwards and ~~The two people on each side of the Table uniformly raise the Jacks to lift the Installation Stand~~ while positioning it to align the Interface Mounting Plate to the Test



*Stand plate mounting locations. Continue cranking until top of **Interface Mounting Plate** touches the Test Stand.*



3.3.12 *Remove four ¼-20 SHCS and “SIDE BEAM” (D1102026) from each side (one at a time, clamping that side before removing the other side).*

3.3.13 *Attach **Interface Mounting Plate** to Test Stand with available Dog Clamps, screws and shims **D1001700**.*



3.3.14 Slowly *crank the lifting Table (D1002192) downwards* ~~lower the Lift Table~~ with attached **Installation Stand**. Watch the Suspension Assembly for any possible obstruction. *Note: Describe the rework needed to keep the installation stand from catching on the bolt heads of the dog clamps.*

3.3.15 Loosen the four Table Dog Clamps on the Table securing the Installation Stand, rotate to release Stand and tighten.

3.3.16 Carefully remove empty Installation Stand and set aside.

3.3.17 Remove the twelve 1/4-20 SHCS attaching the **Secondary Table** to the **Lift Table**. Set screws aside for use in next step.

3.3.18 Carefully remove the **Secondary Table** and set aside.

### 3.4 **Arm Cavity Baffle Box Assembly (D1000977) Installation onto Test Stand**

3.4.1 *Items required for Arm Cavity Baffle Box Assembly Installation, in order of use:*

- 2 - Plain Grip Looped T-Handle Hex Key 3/16" Hex
- 2 - "Wedge Lift, Baffle, Suspension Table" (D1101952)
- 2 - 3/16" Hex Allen tool of 1/4-20 SHCS
- 1 - "Slide, Baffle Carrier Assembly" (D1101958)
- 1 - "Arm Cavity Baffle Box Assembly" (D1000977)
- 1 - Shoulder Screw #10-24 (D1101293)
- 3 - #10 Flat Washers
- 1 - #10 Silver-Plated Nut
- 1 - 3/8" Wrench for #10 Shoulder Screw Nut
- 1 - 1/8" Hex L-Key tool for #10 Shoulder Screw
- 4 - SHCS (1/4-20 x 7/8")

3.4.2 *Use the lifting Table (D1002192) that was used for installation of the Suspension Assy and crank it to the lowest level. Verify Jacks are in completely collapsed state.*

3.4.3 *Attach the two "Wedge Lift, Baffle, Suspension Table" (D1101952) to Jacks with eight 1/4-20 SHCS from Step 2.3.15.*

3.4.4 ~~*Set the "Slide, Baffle Carrier Assembly" (D1101958) into guides on top of the Table.*~~

*Note: the D1101958 was not used in this step. Should it have been?*

3.4.5 *Four people must assist with the lift of the "Arm Cavity Baffle Box Assembly" (D1000977). The Baffle Box weighs about 100 lbs. Carefully lift the Baffle Box and place centered onto Slide Assembly which is on the Table.*

*Note: the screws on the bottom of ACB box interfere with the wedge lift table and don't allow the 3 deg tilt; we placed additional shims under the ACB box to lift the screws away from the wedge lift table. Perhaps, the "Slide, Baffle Carrier Assembly" (D1101958) should have been underneath the ACB box?*

3.4.6 *Install the balance weights in their nominal positions depending upon the specific ACB installation.*

3.4.7 *Position the Baffle Box under the Suspension Assembly, stopping at the approximate location needed to raise and mate the Baffle Box Assembly with the Suspension Assembly.*



- 3.4.8 *Crank lifting Table (D1002192) upwards and* —~~The two people on each side of the Table uniformly raise the Jacks to lift~~ **Baffle Box Assembly** and align to top hinge plate at bottom of **Suspension Assembly**. Adjust **Baffle Box** position *by moving the cranked lower lifting table* as needed for alignment. Continue lift until plates touch.



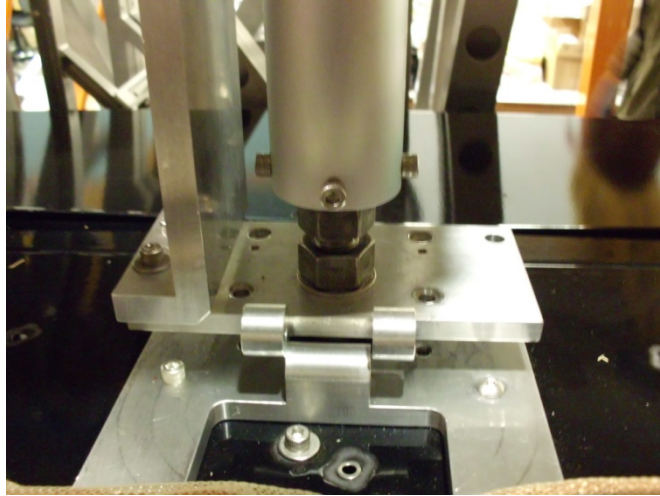

3.4.9 Attach **Baffle Box Assembly** to **Suspension Assembly** with one #10-24 Shoulder Screw (D1101293), three #10 Flat Washers, and one #10 Silver Plated Nut

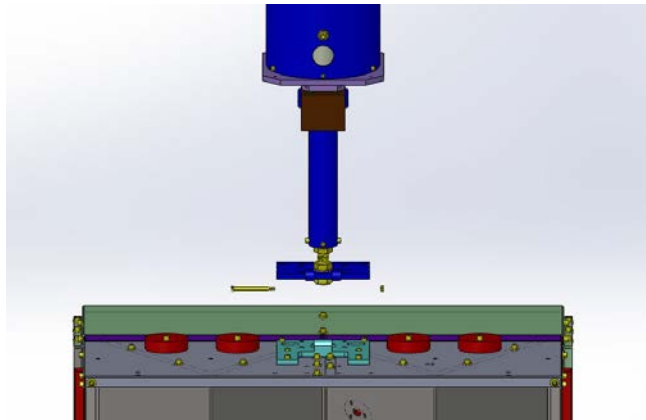

3.4.10 Attach four 1/4-20 SHCS through Top Hinge Plate on Suspension Assembly to Bottom Hinge Plate on Baffle Box Assembly.

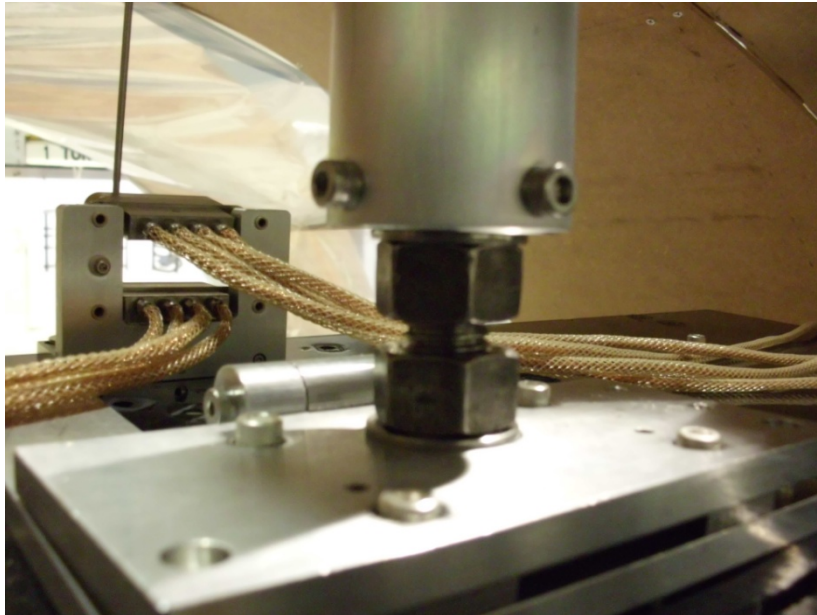
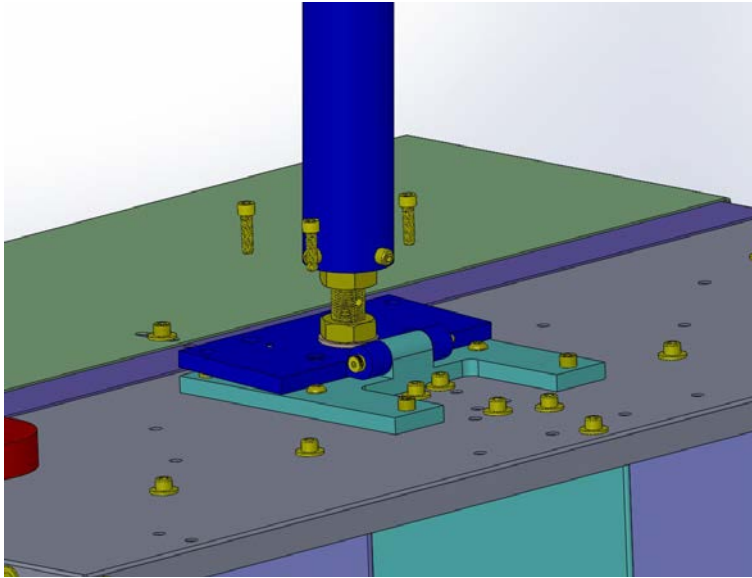

3.4.11 Slowly **crank the lifting table downwards** ~~The two people on each side of the Table uniformly lower the Jacks completely.~~ until the lifting table is approximately one inch below the bottom of the ACB box.

### 3.5 Initial Baffle Balance

3.5.1 *Items required for Baffle Balance, in order of use:*

2 - 3/16" Hex L-Key tool for 1/4-20 SHCS

3.5.2 *Note: The following balancing steps are critically dependent upon the mounting surface of the Test Stand being level (per 2.3.2)!!*

3.5.3 *Determining the Magnitude of Balance Weights*

3.5.3.1 **Verify “Transport, Locking, ACB” (D1101285) is in place. Loosen/remove all four two SHCS in the slotted holes of D1101285 attached to the Lo Tube connector plate D1002618 so that the lo tube can slide freely in the vertical direction. Set aside with hardware for Step 2.6.10.**

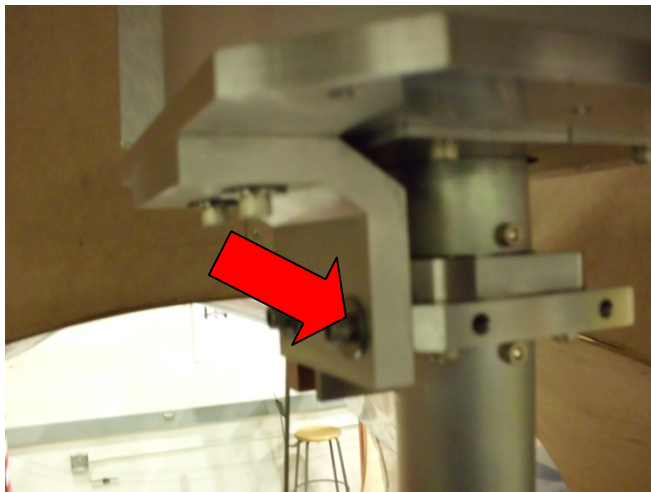

3.5.3.2 **Remove “Height, Adjustment, ACB” (D1101578) and hardware. Set aside with hardware for Step 2.6.10.**

3.5.3.3 **Slowly lower the lifting table with the crank while watching to see if the “ACB Bend Fixture Holder Assembly” (D1102325) pulls away from the interface plate.**

- 1) *If the bend fixture becomes free, stop!! Raise the lifting table with the crank until the bend fixture is again captured by the tip of the blade spring.*
- 2) *Remove some of the free balance weights and repeat step 2.6.2, continuing to repeat this process and removing weights until there is a stable gap of approximately 0.010 between the bend fixture and the interface plate after the lifting table has been lowered so that it no longer supports the ACB. At this point, the proper amount of balance weight has been determined.*

3) If, after removing all of the free balance weights, the baffle is still hanging too low, as seen by observing the gap between the hole in the upper tube and the earthquake rods, proceed to the following steps

**3.5.3.4 Estimate the vertical offset of the upper tube within the earthquake stop rods, and note this dimension.**

**3.5.3.5 Verify that the “ACB Bend Fixture Holder Assembly” (D1102325) is in place.**

**3.5.3.6 Remove the ACB assembly from the Test Stand following the procedure of section 3; disassemble the Suspension Assembly and repeat the assembly step described in E1100867 in which the length of the pivot rod was set by screwing it into the upper tube. However, this time insert the pivot rod into the upper tube by the additional amount noted in 2.6.3.4 to raise the upper tube within the earthquake rod holes.**

**3.5.3.7 After repeating all of the balance steps above beginning with 2.6.3, proceed to the following steps.**

*3.5.4 Remove the “ACB Bend Fixture Holder Assembly” (D1102325).*

*3.5.5 Remove Transport, Locking, ACB” (D1101285) and save parts and hardware for future use.*

*3.5.6 Balance the ACB in the axial and transverse directions by shifting the balance weights axially and laterally until the “SLC Baffle Tube Up Assembly” (D1002582) ~~must be~~ is evenly spaced inside “SLC Earthquake Stop Ring” (D1001120) circumference.*

**Note: DO NOT ROTATE THE ACB BOX WHILE THE TRANSPORT, LOCKING, ACB” (D1101285) IS REMOVED!!**



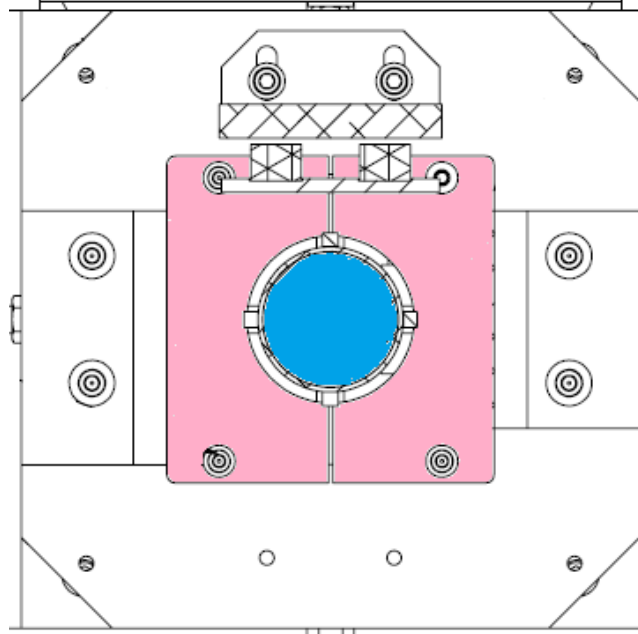

~~3.5.7 Adjust and re-position weights on top of baffle to balance suspended assembly. Additional weights may be required.~~

~~3.5.8 Slide “ACB Adjustable Counter Weight” D1100407 along “ACB Counter Weight” D1100372 to balance Baffle Box. When balanced, lock “ACB Adjustable Counter Weight” D1100407 by tightening screws.~~

3.5.9 When balancing is complete, re-attach “Transport, Locking, ACB” (D1101285) and “Height, Adjustment, ACB” (D1101578).

NOTE: Do NOT re-insert “ACB Bend Fixture Holder Assembly” (D1102325).

3.5.10 **DO NOT REMOVE** the “ACB Adjustable Counter Weight” D1100407 from the “ACB Counter Weight” D1100372.

3.5.11 Disconnect the **Counter Weight Assembly** by removing the six SHCS attached to the **Baffle Box**.

3.5.12 Handle the **Counter Weight Assembly** carefully and store in a secure place to prevent disturbing the placement in preparation for installation. Assembly and screws will be used in Step 5.4.2.

Note: steps 2.6.11 – 2.6.13 may be eliminated with the redesign of the counter weights

## 4 Removal from Test Stand

### 4.1 Removal Preparation

4.1.1 *Items required for Removal Preparation, in order of use:*

Tool for SHCS

Transport, Locking, ACB (D1101285)

Height, Adjustment, ACB (D1101578)

4.1.2 *Verify “**Transport, Locking, ACB**” (D1101285) is in place. Verify all SHCS are tight.*

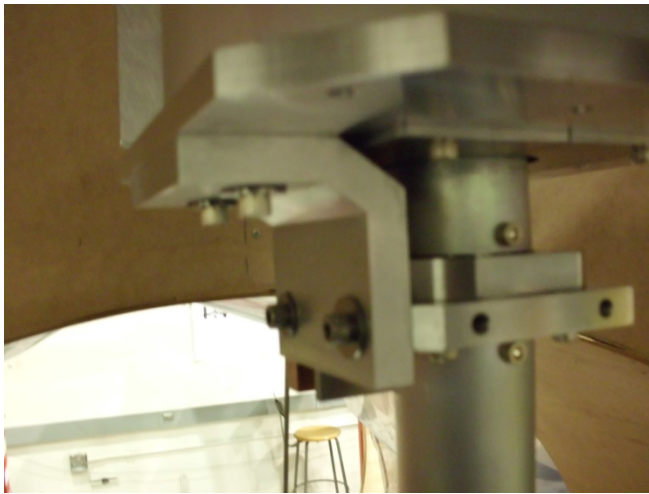

4.1.3 *Verify “**Height, Adjustment, ACB**” (D1101578) is in place. Verify all SHCS are tight.*

4.1.4 *Verify **Jacks** are in completely collapsed state.*

4.1.5 *Position **Slider** underneath the **Baffle Box**.*

## 4.2 Baffle Box Removal

4.2.1 *Items required for Baffle Box Removal, in order of use:*

4.2.2 *Use the lifting Table (D1002192) that was used for installation of the ACB box with the two “**Wedge Lift, Baffle, Suspension Table**” (D1101952) attached to Jacks with eight 1/4-20 SHCS from Step 2.3.15.*

4.2.3 *Verify Jacks are in completely collapsed state.*

4.2.4 *Raise the lifting table with the crank until the table touches the bottom of the ACB box and partially supports it.*

4.2.5 ~~The two people on each side of the Table uniformly raise the Jacks until the Wedge Plates fully support the **Baffle Box Assembly**.~~

4.2.6 *Remove the four 1/4-20 SHCS that attach the Top Hinge Plate on Suspension Assembly to Bottom Hinge Plate on Baffle Box Assembly.*

4.2.7 *Remove the #10-24 Shoulder Screw (D1101293), #10 Flat Washers, and #10 Silver Plated Nut that attach the **Baffle Box Assembly** to the **Suspension Assembly**.*

4.2.8 *Lower the lifting table with the crank until the ACB box is free from the suspension structure*

4.2.9 *Four people must assist with the lift of the “**Arm Cavity Baffle Box Assembly**” (D1000977). The **Baffle Box** weighs about 100 lbs. Carefully lift the **Baffle Box** and set aside.*

~~4.2.10 Remove the **Slider Assembly** from the **Rails**.~~

### 4.3 Suspension Assembly Removal

4.3.1 Items required for **Suspension Assembly** removal, in order of use:

4.3.2 Use the lifting Table (D1002192) that was used for installation of the ACB box with the two "**Wedge Lift, Baffle, Suspension Table**" (D1101952) attached to Jacks with eight 1/4-20 SHCS from Step 2.3.15.

4.3.3 Remove the **Wedge Lifts** from **Jacks**, set screws aside for use in next step.

4.3.4 Verify **Jacks** are in completely collapsed state.

4.3.5 Verify **Dog Clamps** are mounted on **Secondary Table**.

4.3.6 Attach **Secondary Table** to **Lift Assembly** with screws from Step 3.3.2.

**NOTE: Two people must remain beside the "Suspension Lift Assembly" (D1101953).**

4.3.7 Secure **Installation Stand** to **Secondary Table** with the four **Table Dog Clamps** attached to the **Table**.

4.3.8 Loosen **Table Dog Clamps** that secure the **Installation Stand** and align to suspended **Suspension Assembly**

4.3.9 Tighten **Table Dog Clamps** to secure **Installation Stand**

4.3.10 Verify "**Upper Clamp**" (D1102062) from top of **Installation Stand** and "**SIDE BEAM**" (D1102026) are removed.

4.3.11

4.3.12 Crank the lift table to the lowest position. Two people grab the lifting bars on each side of the **Installation Stand** and a 3<sup>rd</sup> person removes the locking pins that secure the telescoping legs. Raise the installation stand to the nearest telescoping leg locking hole that brings the installation stand closest to the Test Stand mounting surface with the **Suspension Assembly** nested inside. Insert the locking pins and secure the telescoping legs.

4.3.13 Slowly crank the lifting table upwards until the Suspension assembly rests on top of the installation stand.

NOTE: The “**ACB\_Stage Zero Narrow\_Guide Block**” (D1101595) and “**ACB\_Stage Zero Narrow-Dog Clamp, End**” (D1101613) must be present in the **Stand**.

4.3.14 Attach the two “**SIDE BEAM**” (D1102026) to the **Installation Stand** with four 1/4-20 SHCS.

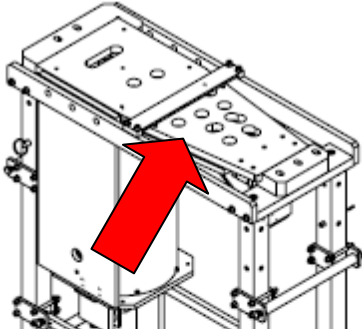

4.3.15 Two people on each side of the Table uniformly lower the **Jacks** to completely collapsed state which causes the **Installation Stand** to lower in preparation for removal.

4.3.16 While the two people on each side of the **Table** completely lower the **Installation Stand** with the **Suspension Assembly** in side.

4.3.17 Attach the “**Upper Clamp**” (D1102062) to top of **Installation Stand** with four SHCS.

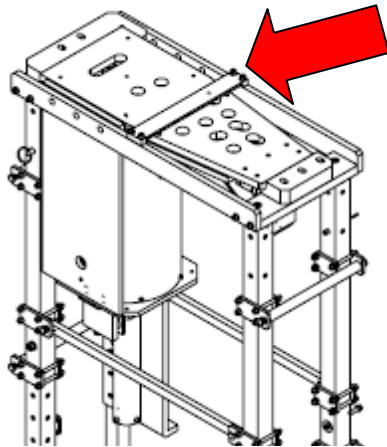

4.3.18 Slowly **crank the lifting table downwards** lower the **Lift Table** with attached **Installation Stand**. Watch the **Suspension Assembly** for any possible obstruction. **Note: Describe the rework needed to keep the installation stand from catching on the bolt heads of the dog clamps?**

4.3.19 Loosen the four **Table Dog Clamps** on the **Secondary Table** securing the **Installation Stand**, rotate to release **Stand** and tighten.

4.3.20 Carefully remove **Installation Stand** with **Suspension Assembly** from *Secondary Table* and place in secure location.

## **Section 2 – ITM Elliptical Baffle Installation onto the BSC ISI Stage-0**

### **5 Installation Preparation**

#### **5.1 Requirements for Installation**

5.1.1 *BSC flooring must be in place before installation can begin.*

5.1.2 *QUAD must be secured and protected (ask SUS) –*

- a) put at least the penultimate and final masses on their stops
- b) attach the "face guard" (the plate attached to the frame in front of the optic -- not sure if this is its proper name)
- c) cover with a C3 fabric "sock"

#### **5.2 Assemblies required for Installation**

5.2.1 *“Rail, ACB Assembly” (D1101724)*

5.2.2 *“Slide, Baffle Carrier Assembly” (D1101958)*

5.2.3 *“Arm Cavity Baffle Box Assembly” (D1000977)*

5.2.4 *“Suspension Lift Assembly” (D1101953), with “Table, Secondary, Suspension” (D1101962), refer to “Installation Suspension Table-Rail Assembly” (D1101971) drawing. Attach four “Table Dog Clamps” (D1001376-2) using four SHCS (1/4-20 x 2”).*

5.2.5 *ACB Plumb Bob Alignment Assembly (D1102370)*

5.2.6 *“ACB\_Installation Stand” (D1101957), with “Arm Cavity Baffle Suspension Assembly” (D1001011), “ACB\_Stage Zero Narrow\_Guide Block” (D1101595) and “ACB\_Stage Zero Narrow-Dog Clamp, End” (D1101613).*

NOTE: The Arm Cavity Baffle Suspension Assembly must also have the following tooling attached: “Transport, Locking, ACB” (D1101285), “Height, Adjustment, ACB” (D1101578), “Plate, Swingback, ACB” (D1101597), and “ACB\_Stage Zero Interface Fixture Mover” (D1101700).

#### **5.3 Other Vacuum Parts required for Installation**

5.3.1 *5 - SHCS (3/8-16 x 2 1/2")*

5.3.2 *5 – 3/8” washers*

- 5.3.3 1 - *Shoulder Screw #10-24 (D1101293)*
- 5.3.4 3 - *#10 Flat Washers*
- 5.3.5 1 - *#10 Silver Plated Nut*
- 5.3.6 4 – *SHCS (1/4-20 x 7/8")*
- 5.3.7 6 - *SHCS (1/4-20 x 1")*
- 5.3.8 12 – *¼" washers*
- 5.3.9 6 – *¼-20 silver-plated Nuts*
- 5.3.10 4 - *"SLC Interface Mounting Clamps" (D1001700)*
- 5.3.11 4 - *SHCS (3/8-16 x 2 1/2")*
- 5.3.12 4 - *3/8" washers*

#### **5.4 Other Non-Vacuum Parts required for Installation**

- 5.4.1 2 - *"Wedge Lift, Baffle, Suspension Table" (D1101952)*
- 5.4.2 2 - *SHCS (¼-20 x .62")*
- 5.4.3 2 - *"ACB\_Interface Fixture Pusher-BSC" (D1101715)*
- 5.4.4 4 – *SHCS (3/8-16 x 1")*
- 5.4.5 4 – *3/8" washers*
- 5.4.6 4 - *SHCS (3/8-16 x 2 1/2")*
- 5.4.7 4 – *3/8" washers*

#### **5.5 Tools required for Installation**

- 5.5.1 2 - *Plain Grip Looped T-Handle Hex Key 3/16" Hex for Jacks*
- 5.5.2 2 - *3/16" Hex L-Key tool for ¼-20 SHCS*
- 5.5.3 2 - *5/16" Hex L-Key tool of 3/8-16 SHCS*
- 5.5.4 1 – *3/8" Wrench for #10 Shoulder Screw Nut*
- 5.5.5 1 - *1/8" Hex L-Key tool for #10 Shoulder Screw*



5.5.6 2 – ¼" Hex L-Key tool for Pushers

5.5.7 2 - Stainless Steel Open-End Wrench for 1-1/8" Nuts

## 6 Installation Procedure

### 6.1 Installation Set-up

6.1.1 *Verify all items in **Section 4.2** have been fully assembled.*

6.1.2 *All ACB assemblies and installation tooling (for the BSC7, BSC8, BSC1, and BSC3) will be brought through the manifold tube leading to the respective chambers and staged in the manifold tube in the following order:*

- 1) - "Suspension Lift Assembly" (D1101953), with "Table, Secondary, Suspension" (D1101962) and four "Table Dog Clamps" (D1001376-2) attached – about **115** pounds
- 2) "Rail, ACB Assembly" (D1101724)
- 3) - "ACB\_Installation Stand" (D1101957), with "Arm Cavity Baffle Suspension Assembly" (D1001011), "ACB\_Stage Zero Narrow\_Guide Block" (D1101595) and "ACB\_Stage Zero Narrow-Dog Clamp, End" (D1101613) installed – about 100 pounds
- 4) 2 - "Wedge Lift, Baffle, Suspension Table" (D1101952) – about 5 pounds each
- 5) "Arm Cavity Baffle Box Assembly" (D1000977) – about **100** pounds sitting on the "Slide, Baffle Carrier Assembly" (D1101958) – about 10 pounds  
 Note: The photodetector cable assemblies and the cable wiring that will attach to the feed-through connector inside the BSC chamber must have been checked out during the assembly procedure to verify electrical continuity to each PD.
- 6) After bringing in the "Arm Cavity Baffle Box Assembly" (D1000977), the person carrying closest to the BSC chamber must also exit from the manifold by stepping around the ACB baffle assembly (this may require a tall person!)

6.1.3 *Items required for installation in order of use and transport down tube:*

- 1 - "Suspension Lift Assembly" (D1101953), with "Table, Secondary, Suspension" (D1101962) and four "Table Dog Clamps" (D1001376-2) attached – about **115** pounds
- 2 - "ACB\_Interface Fixture Pusher-BSC" (D1101715)
- 4 – SHCS (3/8-16 x 1")
- 4 – 3/8" Washers
- 2 - 5/16" Hex Allen tool of 3/8-16 SHCS
- 2 - ACB Plumb Bob Alignment Assembly (D1102370)
- 2 - Plain Grip Looped T-Handle Hex Key 3/16" Hex
- 1 - "ACB\_Installation Stand" (D1101957), with "Arm Cavity Baffle Suspension Assembly" (D1001011), "ACB\_Stage Zero Narrow\_Guide Block" (D1101595) and "ACB\_Stage Zero Narrow-Dog Clamp, End" (D1101613) installed – about **100** pounds  
 NOTE: The Arm Cavity Baffle Suspension Assembly **must** have the following tooling attached: "Transport, Locking, ACB" (D1101285), "Height, Adjustment, ACB" (D1101578), "Plate, Swingback, ACB" (D1101597), and "ACB\_Stage Zero Interface Fixture Mover" (D1101700).
- 2 - 3/16" Hex Allen tool of 1/4-20 SHCS
- 5 - SHCS (3/8-16 x 2 1/2"), **CLASS A**

- 5 – 3/8” washers, **CLASS A**
- 4 - SHCS (3/8-16 x 2 1/2")
- 4 – 3/8” washers
- 2 - “Wedge Lift, Baffle, Suspension Table” (D1101952) – about 5 pounds each
- 1 - “Rail, ACB Assembly” (D1101724) – about 36 pounds
- 2 - SHCS (1/4-20 x .62”)
- 1 - “Slide, Baffle Carrier Assembly” (D1101958) – about 10 pounds
- 1 - “Arm Cavity Baffle Box Assembly” (D1000977) – about **100** pounds
- 1 - Shoulder Screw #10-24 (D1101293)
- 3 - #10 Flat Washers
- 1 - #10 Silver Plated Nut
- 1 – 3/8” Wrench for #10 Shoulder Screw Nut
- 1 - 1/8” Hex L-Key tool for #10 Shoulder Screw
- 4 – SHCS (1/4-20 x 7/8”)
- 1 - pre-set Counter Weight Assembly, from Step 2.6.12.
- 6 - SHCS (1/4-20 x 1”)
- 12 – 1/4” washers
- 6 – 1/4-20 silver-plated Nuts

6.1.4 *One person inside the spool piece will help pass the “Suspension Lift Assembly” (D1101953), with “Table, Secondary, Suspension” (D1101962) and 4 “Table Dog Clamps” (D1001376-2) attached, to two people inside the chamber; wherer they will place it on top of the Teflon mat beneath the Stage 0 position where the ACB suspension will be attached. The Lift Assembly weighs about **115** lbs. and the Secondary Table weighs about 20 lbs.*

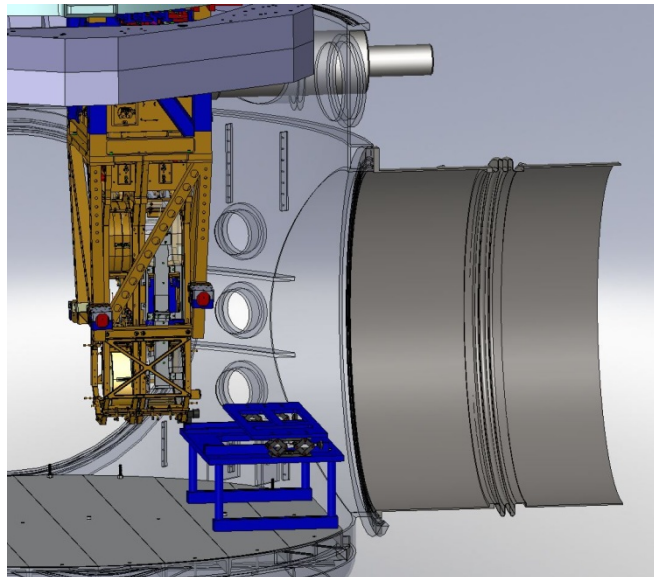

6.1.5 *Adjust position of installation tooling to sit secure and below baffle installation area.*

- 6.1.6 Attach two “**ACB\_Interface Fixture Pusher-BSC**” (D1101715) to **STAGE-0** at **A14, B40 and B42** and **A27, B40 and 42** with four SHCS (3/8-16 x 1”) and 3/8” washers.
- 6.1.7 Attach two “**ACB Plumb Bob Alignment Assembly**” (D1102370) to **STAGE-0** at **A15, B42** and **A27, B40**.
- 6.1.8 Verify **Jacks** are in completely collapsed state.

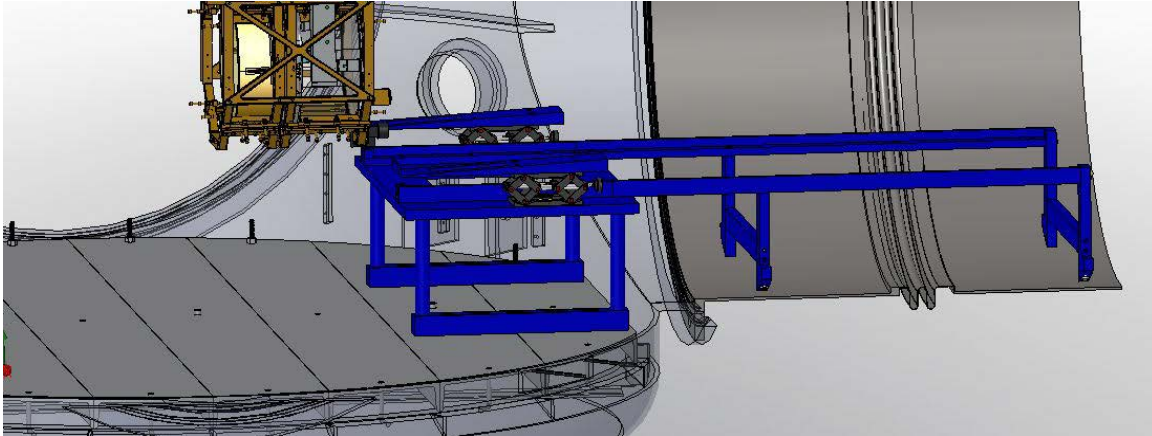

- 6.1.9 Attach the “**Rail, ACB Assembly**” (D1101724) to the “**Suspension Lift Assembly**” (D1101953) using two SHCS (¼-20 x .62”).

## 6.2 Arm Cavity Baffle Suspension Assembly Installation (D1001011)

### 6.2.1 *Items required for Arm Cavity Baffle Suspension Assembly Installation, in order of use:*

1 - “ACB\_Installation Stand” (D1101957), with “Arm Cavity Baffle Suspension Assembly” (D1001011), “ACB\_Stage Zero Narrow\_Guide Block” (D1101595) and “ACB\_Stage Zero Narrow-Dog Clamp, End” (D1101613) installed.

NOTE: The Arm Cavity Baffle Suspension Assembly **must** have the following tooling attached: “Transport, Locking, ACB” (D1101285), “Height, Adjustment, ACB” (D1101578), “Plate, Swingback, ACB” (D1101597), and “ACB\_Stage Zero Interface Fixture Mover” (D1101700).

- 2 - 3/16” Hex L-Key tool for 1/4-20 SHCS
- 2 - Plain Grip Looped T-Handle Hex Key 3/16” Hex
- 5 - SHCS (3/8-16 x 2 1/2”), **CLASS A**
- 5 – 3/8” washers, **CLASS A**
- 2 - 5/16” Hex L-Key tool of 3/8-16 SHCS
- 4 - SHCS (3/8-16 x 2 1/2”)
- 4 – 3/8” washers

6.2.2 *Two people will enter the spool and pass through into the manifold. They will lift and carry the **Arm Cavity Baffle Suspension Assembly**” (D1001011), which is secured in the expandable “**Installation Stand**” (D1101957) in its collapsed and locked configuration, from the manifold, into the spool, and help pass it to another person in the chamber. One person will exit the spool and help the person inside the chamber to carefully place it on top of the “**Table, Secondary, Suspension**” (D1101962). Total weight is about **100 lbs**. There are handles on the Installation Stand for lifting and carrying.*

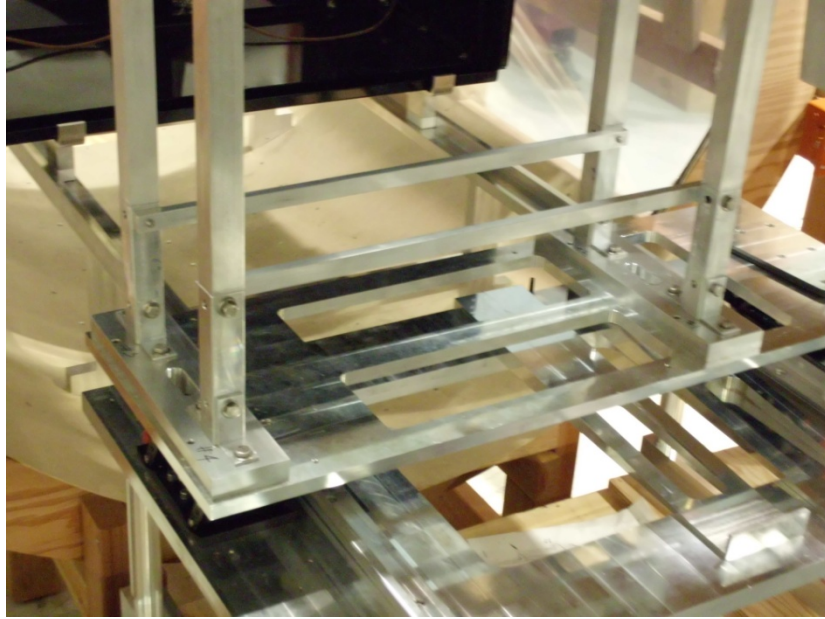

6.2.3 The two people inside the chamber will adjust the **Table, Secondary, Suspension** (D1101962) so that it is directly below the Stage 0 position where the ACB suspension will be attached.

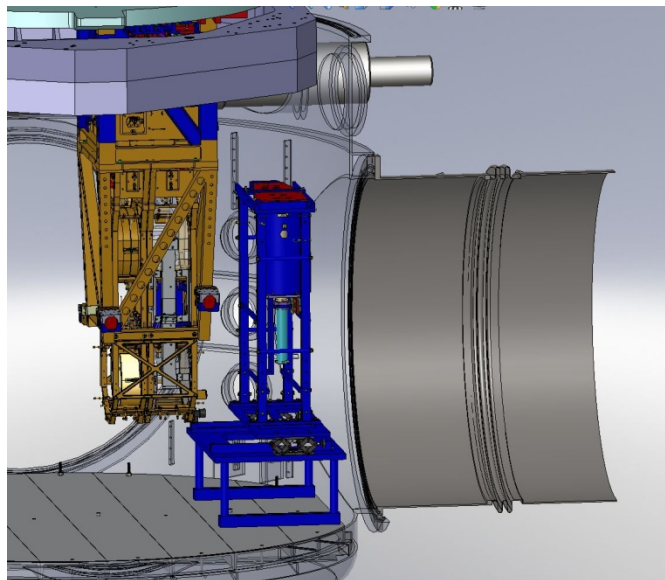

- 6.2.4 One person (minimum) remains positioned inside the spool during the entire installation
- 6.2.5 Two people remain in the chamber, one on each side of the **“Suspension Lift Assembly”** (D1101953).
- 6.2.6 Secure **Installation Stand** to **Secondary Table** with the four **Table Dog Clamps** attached to the **Table**.



- 6.2.7 Loosen **Table Dog Clamps** that secure the **Installation Stand** to the **Secondary Table**. Either slide the **Suspension Lift Assembly** (D1101953) on the Teflon mat, and/or loosen the dog clamps and move the **Installation Stand** to align “ACB\_Stage Zero Narrow\_Guide Block” (D1101595) and “ACB\_Stage Zero Narrow-Dog Clamp, End” (D1101613) with the tip of the **Plumb Bobs**.
- 6.2.8 Tighten **Table Dog Clamps** to secure **Installation Stand**.
- 6.2.9 Disconnect both **Plumb Bobs** and remove from vacuum system.
- 6.2.10** With **Installation Stand** secured, remove four SHCS and “**Upper Clamp**” (D1102062) from top of **Installation Stand**. Remove parts from vacuum system.

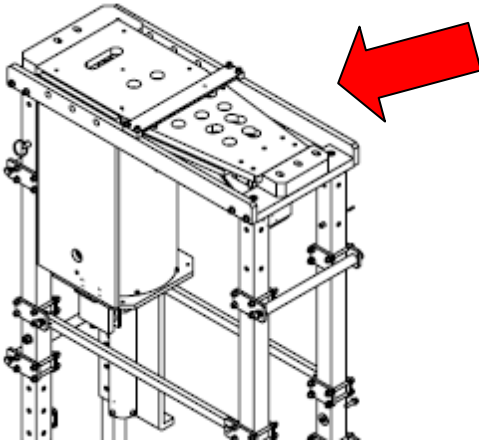

- 6.2.11 The person positioned in the spool pulls out the four **Locking Pins** in the **Installation Stand** legs.
- 6.2.12 The two people on each side of the **Table** grasps the handles on **Installation Stand** and lifts the **Stand** until it nearly touch **STAGE-0**. The person in the spool locks the **Stand** into position by inserting the four **Locking Pins**. Some adjustment to the expansion height may be needed to align the holes for locking.

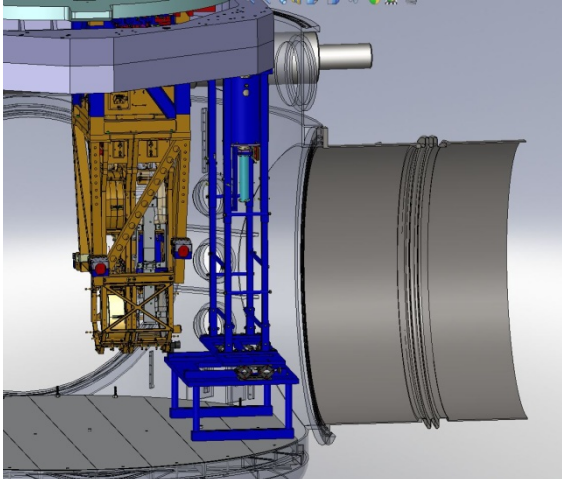

NOTE: There is approximately 8 inches between the **Installation Stand** and the **QUAD**.





6.2.13 The two people on each side of the **Table** uniformly raise the **Jacks** to lift the **Installation Stand** and align **Interface Mounting Plate** to **STAGE-0** mounting locations. Continue until top of **Interface Mounting Plate** touches **STAGE-0**.

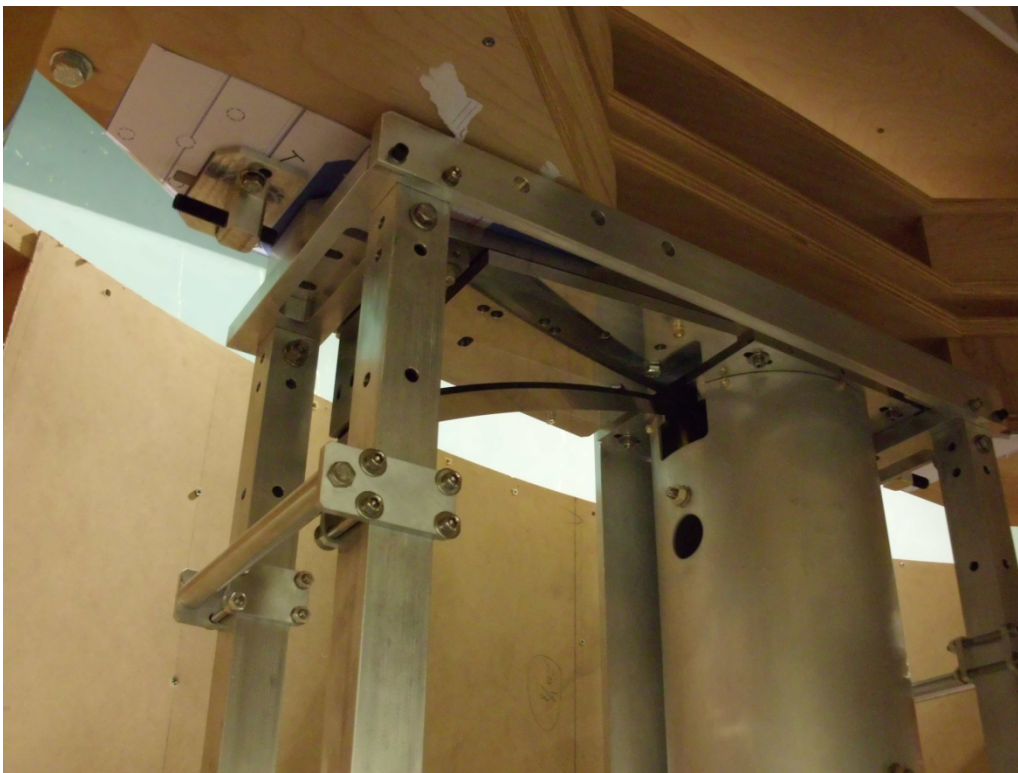

6.2.14 Attach "**ACB\_Stage Zero Narrow\_Guide Block**" (D1101595) and "**ACB\_Stage Zero Narrow-Dog Clamp, End**" (D1101613) to **STAGE-0** with five SHCS (3/8-16 x **2 1/2"**) and 3/8" washers.

6.2.15 Attach "**ACB\_Stage Zero Interface Fixture Mover**" (D1101700), which is attached to the "**SLC ACB Interface Mounting Plate**" (D1001138), to **STAGE-0** with four SHCS (3/8-16 x **2 1/2"**) and 3/8" washers.



6.2.16 Remove four 1/4-20 SHCS and "**SIDE BEAM**" (D1102026) from **Installation Stand** on the side closest to the chamber wall. Remove from vacuum system.

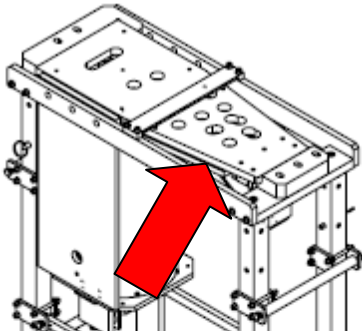

6.2.17 The two people on each side of the **Table** uniformly lower the **Jacks** to their completely collapsed state which causes the **Installation Stand** to lower in preparation for removal. Watch the **Suspension Assembly** for any possible obstruction.

6.2.18 While the two people on each side of the **Table** grasps the handles on **Installation Stand**, the person positioned in the spool disengages the four **Locking Pins** in **Installation Stand** legs.

6.2.19 The two people grasping the handles slowly lower the **Installation Stand** until it returns to the completely collapsed position.

6.2.20 The person positioned in the spool then inserts the four **Locking Pins** into the **Installation Stand** legs.

6.2.21 Loosen the four **Table Dog Clamps** on the **Table** securing the **Installation Stand**, rotate to release **Stand** and tighten.

6.2.22 Carefully remove the empty **Installation Stand** from the BSC through the chamber door.





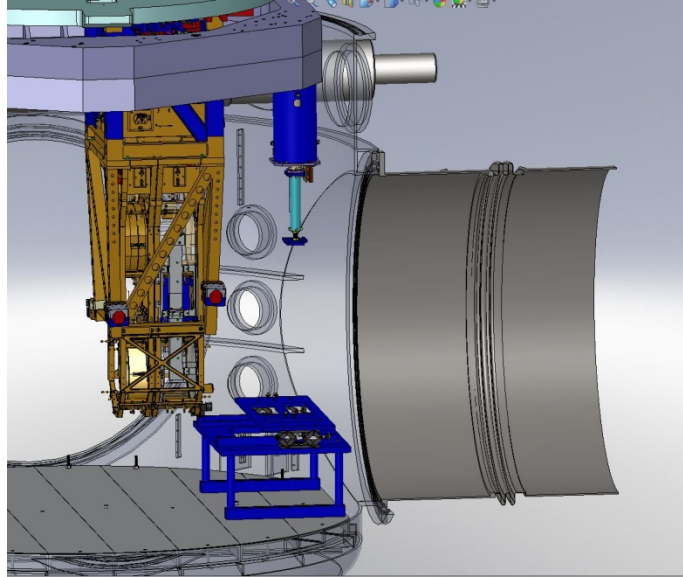

6.2.23 Remove the twelve 1/4-20 SHCS attaching the **Secondary Table** to the **Suspension Lift Assembly**. Place SHCS on aluminum foil container in bottom of spool for use in next step. Carefully remove the **Secondary Table** from vacuum system.

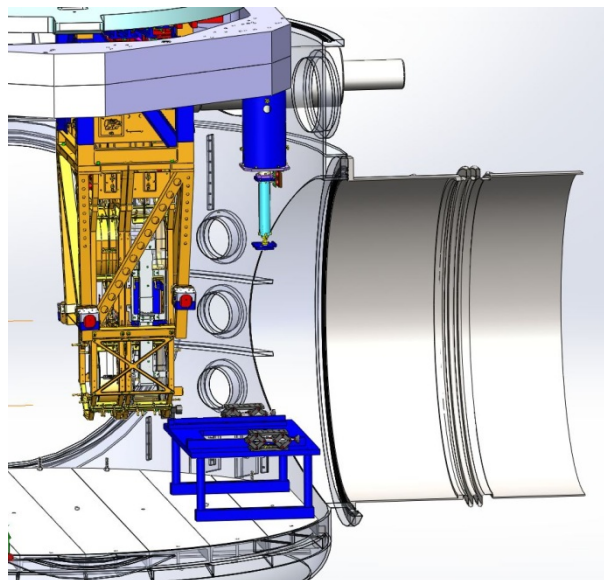

### 6.3 Arm Cavity Baffle Box Assembly Installation (D1000977)

#### 6.3.1 Items required for Arm Cavity Baffle Box Assembly Installation, in order of use:

- 2 - Plain Grip Looped T-Handle Hex Key 3/16" Hex
- 2 - "Wedge Lift, Baffle, Suspension Table" (D1101952)
- 8 - 1/4-20 SHCS from Step 5.2.23
- 3/16" Hex L-Key tool of 1/4-20 SHCS
- 1 - "Rail, ACB Assembly" (D1101724)
- 2 - SHCS (1/4-20 x .62")
- 1 - "Slide, Baffle Carrier Assembly" (D1101958)
- 1 - "Arm Cavity Baffle Box Assembly" (D1000977)
- 1 - Shoulder Screw #10-24 (D1101293)
- 3 - #10 Flat Washers
- 1 - #10 Silver Plated Nut
- 1 - 3/8" Wrench for #10 Shoulder Screw Nut
- 1 - 1/8" Hex L-Key tool for #10 Shoulder Screw
- 4 - SHCS (1/4-20 x 7/8")

#### 6.3.2 Verify **Jacks** are in completely collapsed state.

#### 6.3.3 Attach the two "**Wedge Lift, Baffle, Suspension Table**" (D1101952) stored in manifold to Jacks with eight 1/4-20 SHCS from Step 5.2.23.

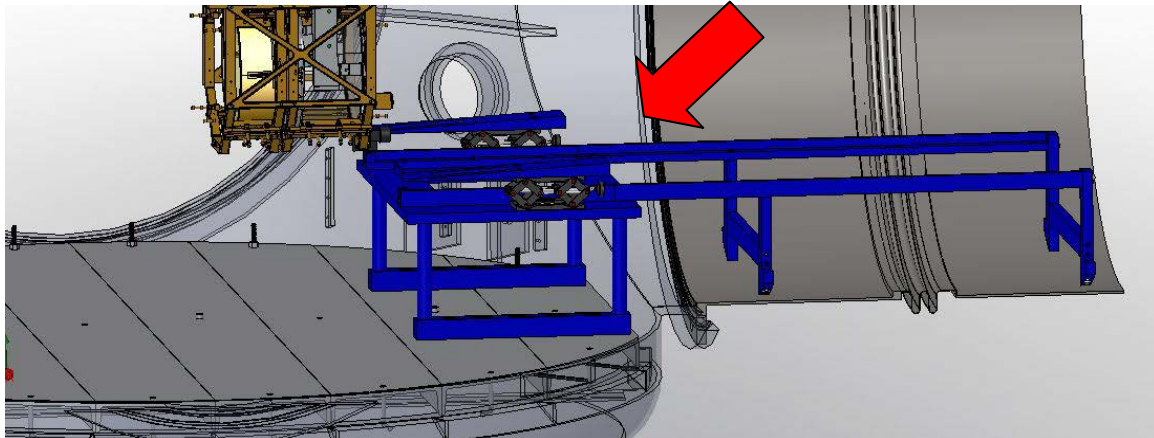

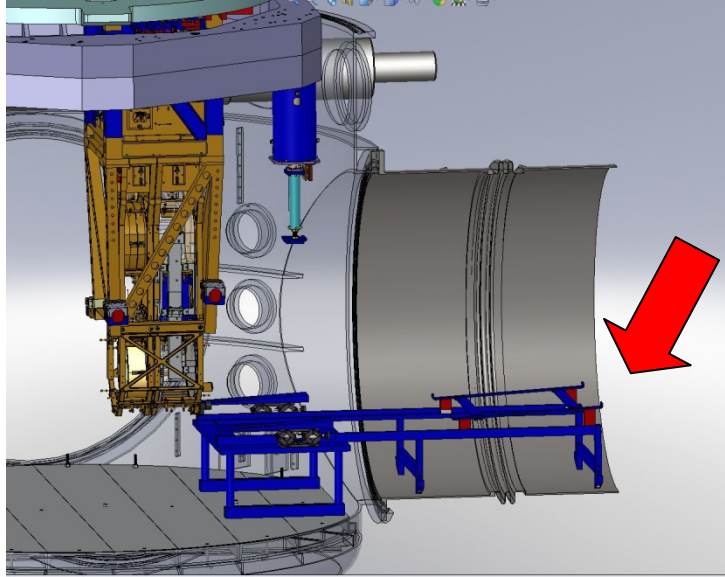

6.3.4 Using the “**Slide, Baffle Carrier Assembly**” (D1101958) and the “sedan chair” rods to lift the “**Arm Cavity Baffle Box Assembly**” (D1000977), which is stored in the manifold, two people will carry it and place the **Slide, Baffle Carrier Assembly** (supporting the baffle box) into the guides on top of “**Rail, ACB Assembly**” (D1101724); one person will be positioned in the spool behind the Baffle Box and another in front of the baffle box. The **Baffle Box** weighs about 100 lbs.

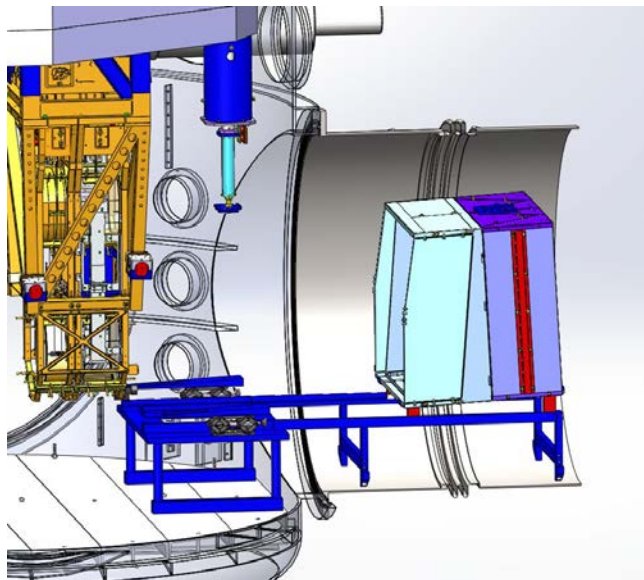

6.3.5 The **Slide Assembly** feet have Teflon pads that allow for an easy slide down the rail. There are blocks attached to the end of the rails to prevent travel past the **Table** end. Slide the **Baffle Box** toward the QUAD until it is

positioned directly above the **Wedge Lift, Baffle, Suspension Table**” (D1101952, stopping at the approximate location needed to raise and mate the **Baffle Box Assembly** with the **Suspension Assembly**).

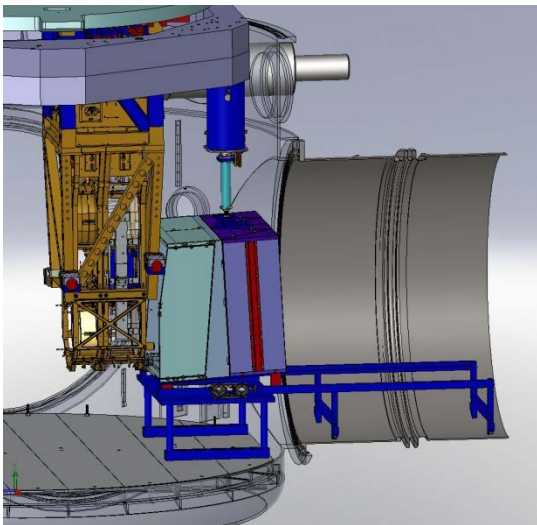
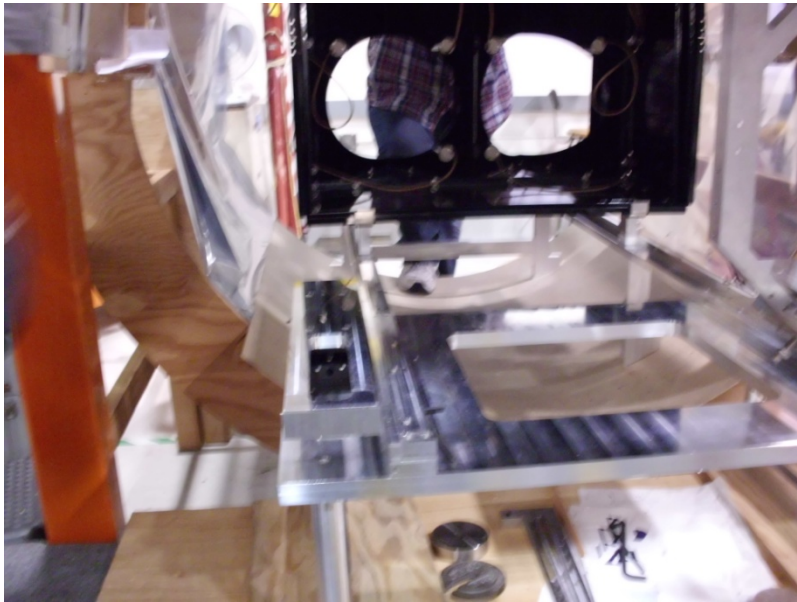



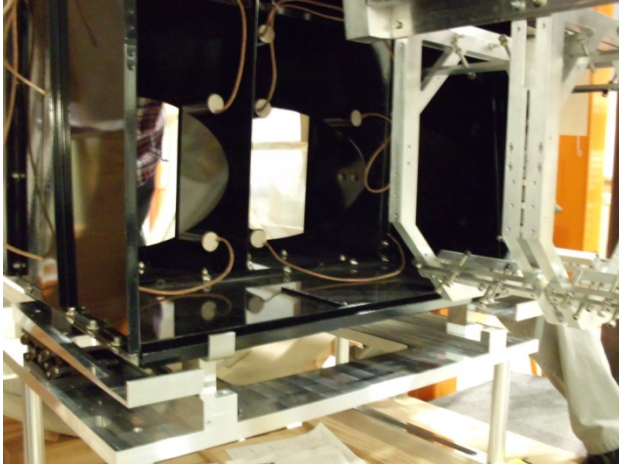

6.3.6 The two people on each side of the **Table** uniformly raise the **Jacks** to lift **Baffle Box Assembly** and align to top hinge plate at bottom of **Suspension Assembly**. Adjust **Baffle Box** position as needed for alignment. Continue lifting until hinge plates touch.

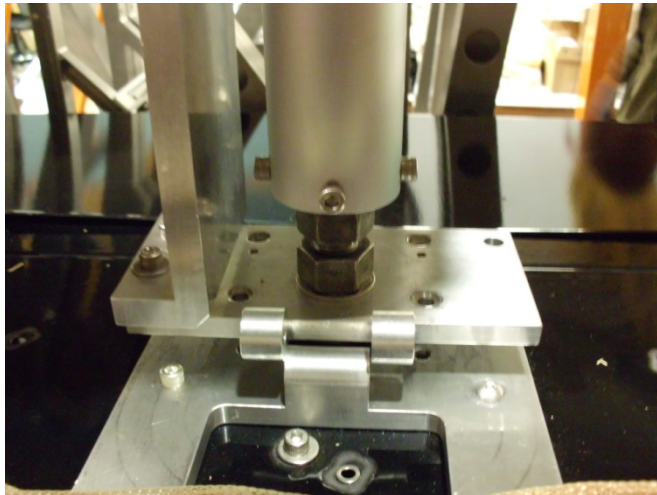



- 6.3.7 Attach **Baffle Box Assembly** to **Suspension Assembly** with one #10-24 Shoulder Screw (D1101293), three #10 Flat Washers, and one #10 Silver Plated Nut

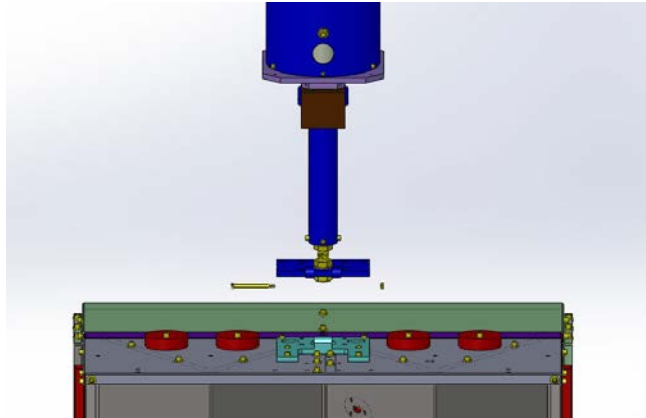

- 6.3.8 Attach four SHCS (1/4-20 x 7/8") through **Top Hinge Plate** on **Suspension Assembly** to **Bottom Hinge Plate** on **Baffle Box Assembly**.

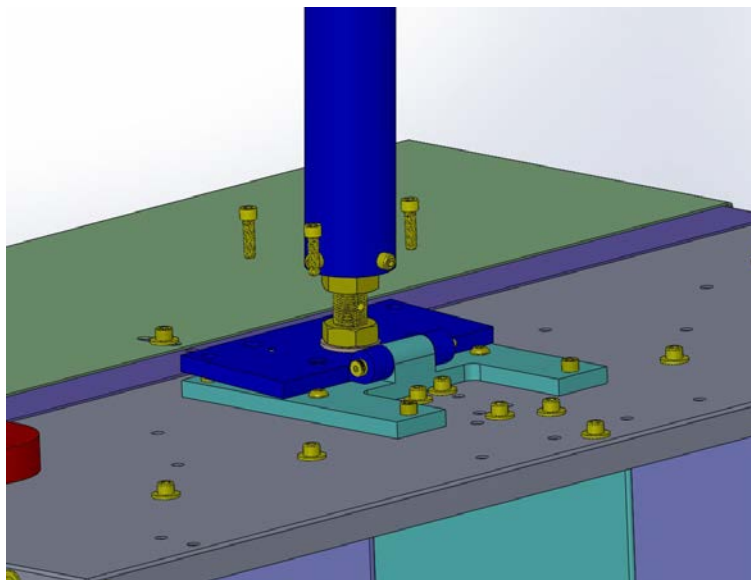

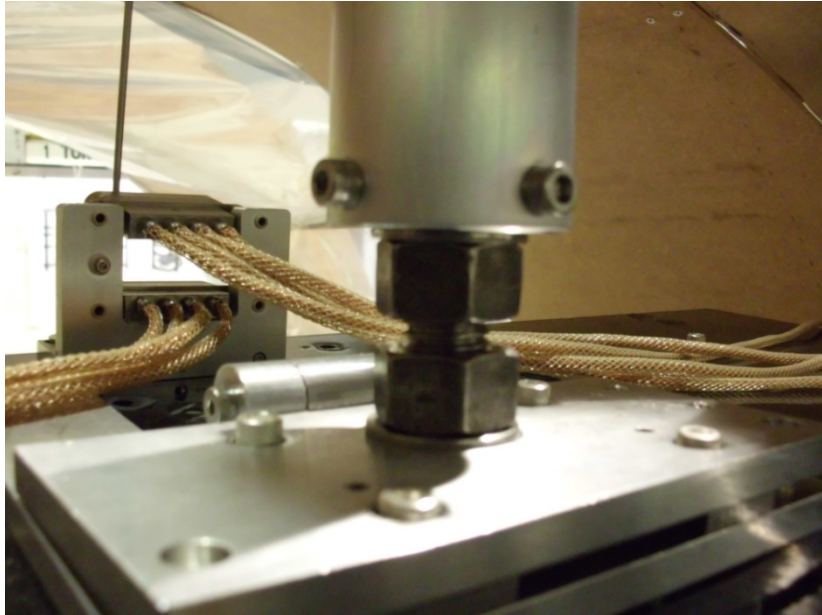

6.3.9 The two people on each side of the **Table** uniformly lower the **Jacks** completely.

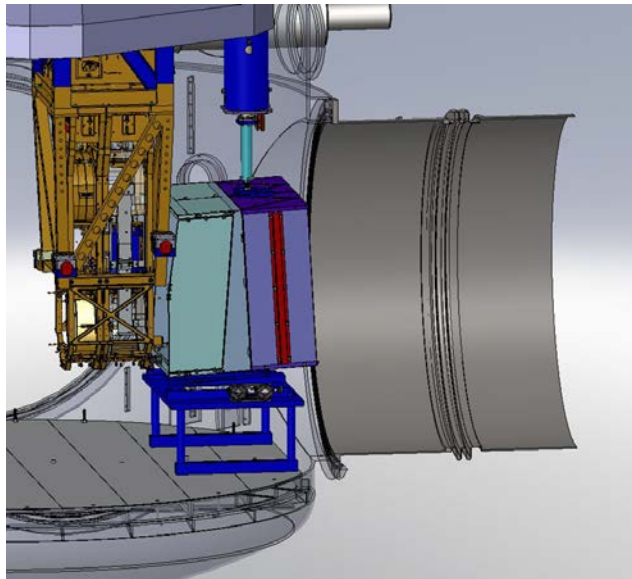



6.3.10 Pull **Slide Assembly** along **Rail Assembly** to end toward spool, and leave it there until later removing through the manifold tube.

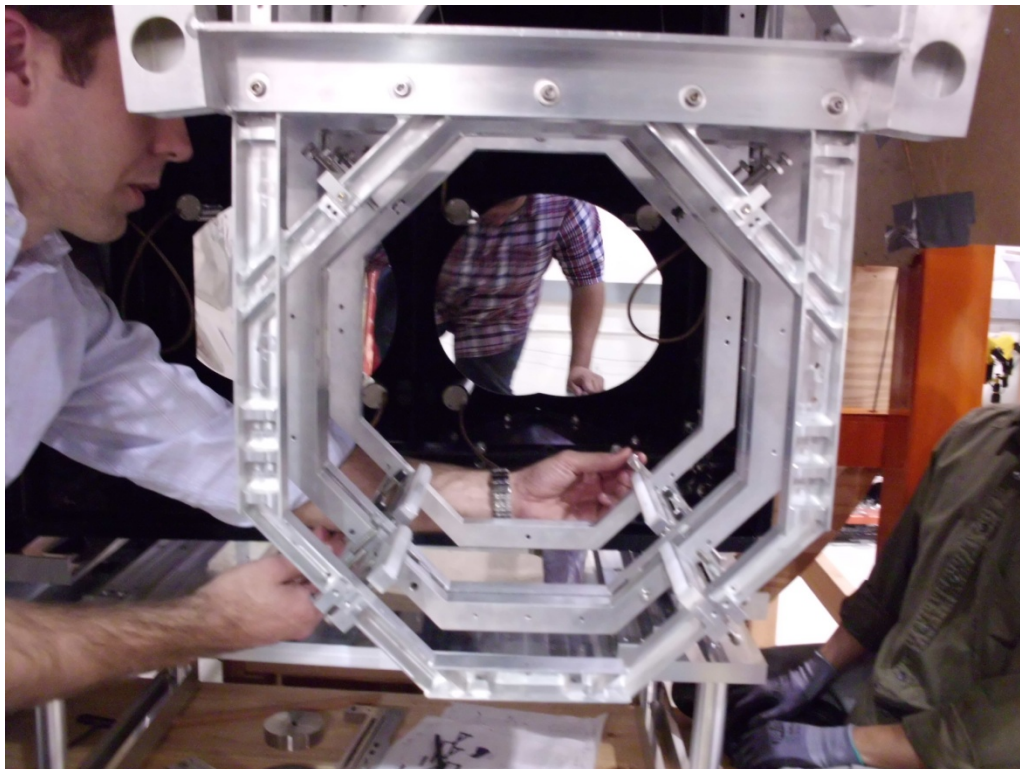

6.3.11 Detach **Rail Assembly** from **Table** and store in the manifold for later removal from vacuum system.

6.3.12 Remove **Table** from BSC through chamber door.

6.3.13 Remove Teflon mat from BSC through chamber door.

## 6.4 Baffle Alignment

### 6.4.1 Items required for Baffle Alignment, in order of use:

- 2 - 5/16" Hex L-Key tool of 3/8-16 SHCS
- 2 - 1/4" Hex L-Key tool for Pushers
- 4 - "SLC Interface Mounting Clamps" (D1001700)
- 4 - SHCS (3/8-16 x 2 1/2")
- 4 - 3/8" washers

#### Tool for Bracket SHCS

#### Allen Tool in hole of "Screw #3/4-10 X 4" (D1001186)

- 2 - Stainless Steel Open-End Wrench for 1-1/8" Nuts

### 6.4.2 Theodolite Setup

IAS group will set up theodolite from open end of manifold aligned with center of COC TM, according to procedure XXX?

6.4.3 Remove the two 1/4-20 SHCS attaching the **Interface Fixture Mover** to the **Interface Mounting Plate**. Remove from vacuum system.

6.4.4 Remove **Height Adjustment Variable** (D1102321) and **Bracket, Variable Height Adjustment** (D1102323) so that the Baffle can move freely. Save parts and hardware for future use.

6.4.5 Remove **Transport, Locking, ACB** (D1101285) and save parts and hardware for future use.

6.4.6 Verify balance of baffle. Shift balance weights as needed axially and laterally until the "**SLC Baffle Tube Up Assembly**" (D1002582) is evenly spaced inside "**SLC Earthquake Stop Ring**" (D1001120) circumference.

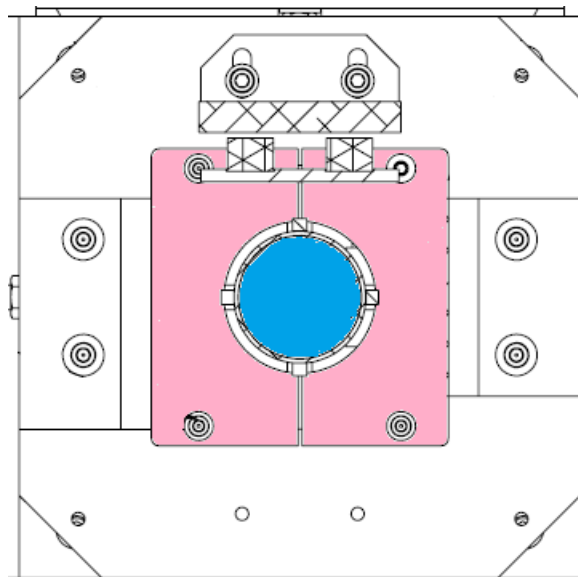



**Lateral Alignment**

- 6.4.7 Slightly loosen five SHCS attaching “**STAGE-0 Guide Block**” (D1101595) and “**STAGE-0 Dog Clamp**” (D1101613)
- 6.4.8 Slightly loosen four SHCS attaching “**ACB\_Stage Zero Interface Fixture Mover**” (D1101700), which is attached to the “**SLC ACB Interface Mounting Plate**” (D1001138), to **STAGE-0**
- 6.4.9 Manually position **Suspension Assembly** (D1001011) into **Guide Block and Clamp** so that it is flush with **Guide Block** corners.
- 6.4.10 Move the interface plate by turning the Threaded Thrust Screws on the “**ACB\_ Interface Fixture Pusher-BSC**” (D1101715) to align the baffle laterally. There is a Pusher Assembly on both ends of the baffle attached to **STAGE-0** to move in either direction.

**NOTE: DO NOT REMOVE THE LATERAL ALIGNMENT TOOLING UNTIL VERTICAL ALIGNMENT IS COMPLETE, IN CASE WE NEED TO ITERATE!**

- 6.4.11 Tighten the five SHCS attaching **Guide Block** and **Clamp** to **STAGE-0**.

**Vertical Alignment**

- 6.4.12 Attach the “**Transport, Locking, ACB**” (D1101285). **Tighten** the two upper SHCS. **Loosely** attach the two lower SHCS in the slotted holes in order to keep the **Up Tube** from rotating, but allow vertical movement.

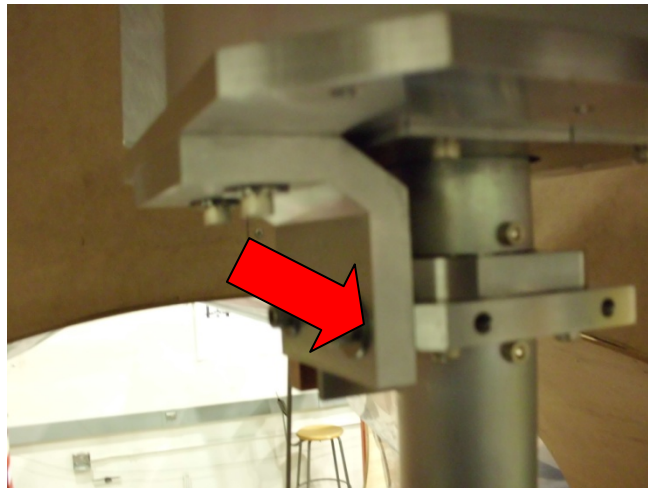

- 6.4.13 Attach the **Height Adjustment Variable** (D1102321) and **Bracket, Variable Height Adjustment** (D1102323) to the **Upper Hinge Plate** and

**8" Diameter Tube Plate.** Tighten SHCS in slotted holes. Do not attach Bracket to the Up Tube.

6.4.14 Insert Allen Tool in hole of "**Screw #3/4-10 X 4**" D1001186

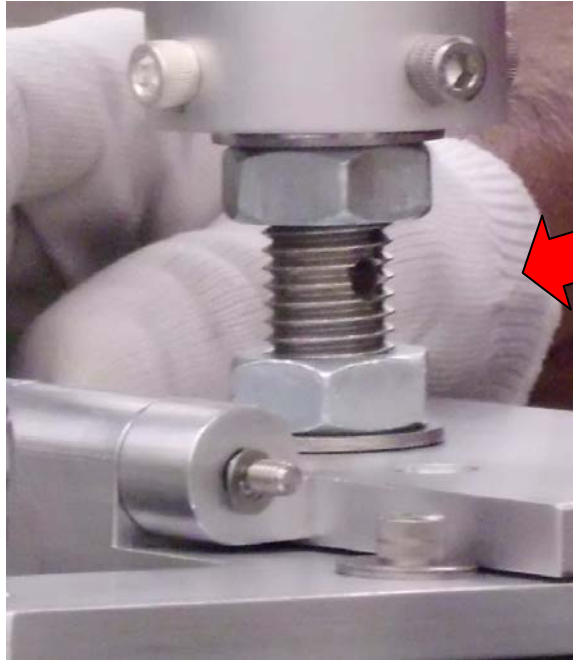

6.4.15 Loosen both "**Nickel Copper Hex Nuts, 3/4"-10**", D1102316.

6.4.16 Loosen the SHCS of the **Variable Bracket Assembly** in the slotted holes, so that the ACB can move vertically when the height adjustment screw is turned.

6.4.17 Adjust baffle height by turning the #3/4-10 X 4" screw until the lateral edges of the baffle hole are centered with the center of the TM, as determined by the theodolite readings.

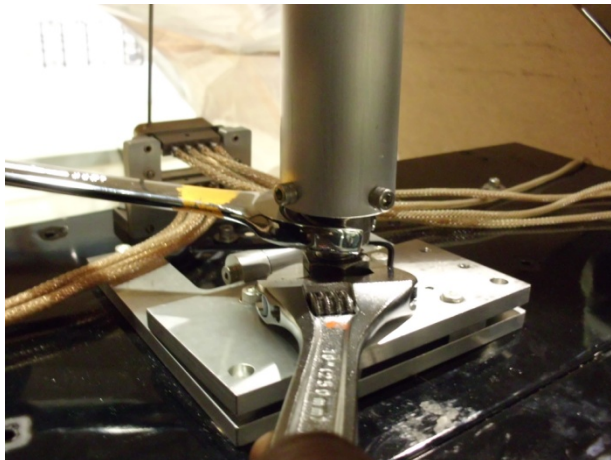



6.4.18 When correct height is obtained, **tighten the SHCS of the Variable Bracket Assembly in the slotted holes.**

6.4.19 Tighten both **“Nickel Copper Hex Nut, 3/4”-10”**, D1102316.

6.4.20 Remove Allen Tool in hole of **“Screw #3/4-10 X 4”** D1001186.

### **Iteration of Alignment Steps**

- 1) Remove the **“Transport, Locking, ACB”** (D1101285) so that the ACB hangs freely.
- 2) Remove the Height Adjustment Variable (D1102321) and Bracket, Variable height Adjustment (D1102323)
- 3) Verify alignment.
- 4) Repeat the lateral alignment starting at Step 5.5.7, and the vertical alignment starting at Step 5.5.12, as needed.

6.4.21 Attach the **“Transport, Locking, ACB”** (D1101285) and tighten all SHCS.

6.4.22 Attach Height Adjustment Variable (D1102321) and Bracket, Variable height Adjustment (D1102323).

6.4.23 Verify the **“STAGE-0 Guide Block”** (D1101595) and **“STAGE-0 Dog Clamp”** (D1101613) are securely holding the **Interface Mounting Plate**.

6.4.24 Tighten the five SHCS attaching **“STAGE-0 Guide Block”** (D1101595) and **“STAGE-0 Dog Clamp”** (D1101613)

6.4.25 Remove the **Mover Plate** with the four SHCS and washers attaching the **Mover Plate** to STAGE-0. Set SHCS and washers aside for re-use in next step. Remove the **Mover Plate** from vacuum system.

6.4.26 Attach **Interface Mounting Plate** to STAGE-0 with four **“SLC Interface Mounting Clamps”** (D1001700), four CLASS A SHCS (3/8-16 x 2”) and four 3/8” washers.

6.4.27 Remove the two **Pusher Fixtures** with the four SHCS and washers attaching the **Pusher Fixtures** to STAGE-0. Remove from vacuum system.

6.4.28 Remove the five SHCS attaching **“STAGE-0 Guide Block”** (D1101595) and **“STAGE-0 Dog Clamp”** (D1101613). Remove from vacuum system.

## **7 Removal of Fixtures and Tooling**

### **7.1 After Installation**

*7.1.1 Fixed Bracket*

### **7.2 After Alignment**

*7.2.1 Pushers*

*7.2.2 Mover Plate*

*7.2.3 Variable Height Adjustment Bracket Assembly*

*7.2.4 Transport, Locking, ACB (D1101285)*