

*LIGO Laboratory / LIGO Scientific Collaboration*

LIGO- T1100446-v4

*LIGO*

3/26/13

---

AOS SLC  
ITM Elliptical Baffle  
Final Design

---

Michael Smith, Lisa C. Austin, Heidy Kelman, Virginio Sannibale, Tim Nguyen, Manuel Ruiz

Distribution of this document:  
LIGO Scientific Collaboration

This is an internal working note  
of the LIGO Laboratory.

**California Institute of Technology**  
**LIGO Project – MS 18-34**  
**1200 E. California Blvd.**  
**Pasadena, CA 91125**  
Phone (626) 395-2129  
Fax (626) 304-9834  
E-mail: [info@ligo.caltech.edu](mailto:info@ligo.caltech.edu)

**Massachusetts Institute of Technology**  
**LIGO Project – NW22-295**  
**185 Albany St**  
**Cambridge, MA 02139**  
Phone (617) 253-4824  
Fax (617) 253-7014  
E-mail: [info@ligo.mit.edu](mailto:info@ligo.mit.edu)

**LIGO Hanford Observatory**  
**P.O. Box 159**  
**Richland WA 99352**  
Phone 509-372-8106  
Fax 509-372-8137

**LIGO Livingston Observatory**  
**P.O. Box 940**  
**Livingston, LA 70754**  
Phone 225-686-3100  
Fax 225-686-7189

<http://www.ligo.caltech.edu/>

**CHANGE LOG**

<b>Date, version</b>	<b>Summary of Changes</b>
3/26/13 V4	<ul style="list-style-type: none"><li>• Updated review committee recommendations</li><li>• Corrected aperture size in Table 1, and scattered light calculation p. 17</li><li>• Corrected IFO solid angle, 4.3.2, 4.3.3, 4.3.4</li></ul>

## Table of Contents

<b><u>Table of Tables</u></b> .....	<b>4</b>
<b>1 INTRODUCTION</b> .....	<b>5</b>
1.1 Scope .....	<b>5</b>
1.2 <b>Final Design Review Checklist</b> .....	<b>5</b>
1.2.1 Final requirements – any changes or refinements from PDR? .....	5
Direct Requirements .....	5
ITM Elliptical Baffle Requirements .....	5
New: Clear Aperture Requirements .....	5
1.2.2 Resolutions of action items from SLC PDR.....	5
Lower BRDF Material for Baffles .....	5
1.2.3 Final Parts Lists and Drawing Package .....	6
1.2.4 Final specifications .....	6
1.2.5 Final interface control documents.....	6
1.2.6 Relevant RODA changes and actions completed .....	6
1.2.7 Signed Hazard Analysis.....	6
1.2.8 Final Failure Modes and Effects Analysis.....	6
1.2.9 Risk Registry items discussed.....	6
1.2.10 Design analysis and engineering test data .....	6
1.2.11 Software detailed design.....	6
1.2.12 Final approach to safety and use issues .....	6
1.2.13 Production Plans for Acquisition of Parts, Components, Materials Needed For Fabrication .....	7
1.2.14 Installation Plans and Procedures .....	7
1.2.15 Final hardware test plans .....	7
1.2.16 Final software test plans .....	7
1.2.17 Cost compatibility with cost book .....	7
1.2.18 Fabrication, installation and test schedule .....	7
1.2.19 Lessons Learned Documented, Circulated .....	7
1.2.20 Porcelainizing .....	7
1.2.21 Problems and concerns .....	7
1.3 <b>Applicable Documents</b> .....	<b>7</b>
<b>2 BAFFLE DESCRIPTIONS</b> .....	<b>9</b>
2.1 <b>FUNCTION</b> .....	<b>9</b>
2.1.1 ITM ELLIPTICAL BAFFLE.....	9
2.2 <b>H1 &amp; L1 IFO ZEMAX LAYOUT</b> .....	<b>9</b>
<b>3 DESCRIPTIONS OF BAFFLES</b> .....	<b>10</b>
3.1 <b>SUSPENSION</b> .....	<b>10</b>
3.1.1 Transmissibility Measurements .....	10
3.1.2 Stray Magnetic Field Measurement.....	10
3.1.3 Earthquake Stops .....	10
3.1.4 Eddy Current Damping.....	11

<b>3.2 ITM ELLIPTICAL BAFFLE .....</b>	<b>12</b>
3.2.1 ITM Elliptical Baffle Vibration Analysis .....	13
3.2.2 ITM Elliptical Baffle Physical Characteristics .....	14
<b>3.3 OPTICAL INTERFACES .....</b>	<b>14</b>
3.3.1 ITM Elliptical Baffle .....	14
<b>4 SCATTERED LIGHT DISPLACEMENT NOISE .....</b>	<b>14</b>
<b>4.1 Scattered Light Requirement .....</b>	<b>14</b>
<b>4.2 Scattered Light Parameters .....</b>	<b>16</b>
4.2.1 BRDF of Baffle Surfaces .....	18
4.2.2 BSC Seismic Motion .....	18
<b>4.3 ITM Elliptical Baffle.....</b>	<b>20</b>
4.3.1 ITM Elliptical Baffle Suspension Transmissibilities.....	20
4.3.2 ITM Elliptical Baffle Scatter .....	22
4.3.3 ITM Elliptical Baffle Reflection, Scatter from Walls.....	23
4.3.4 ITM Elliptical Baffle Hole Edge Scatter .....	23
<b>4.4 Scattered Light Displacement Noise Summary.....</b>	<b>25</b>
<b>5 INTERFACE CONTROL DOCUMENT.....</b>	<b>25</b>

#### Table of Figures

<i>Figure 1: BSC2: ITM Elliptical Baffles.....</i>	<i>9</i>
<i>Figure 2: Preliminary Longitudinal Transmissibility of ITM Elliptical Baffle Suspension.....</i>	<i>10</i>
<i>Figure 3: Earthquake Stops.....</i>	<i>11</i>
<i>Figure 4: Eddy Current Damping Apparatus.....</i>	<i>12</i>
<i>Figure 5: ITM Elliptical Baffle.....</i>	<i>13</i>
<i>Figure 7: Scattered Light Noise Transfer Functions.....</i>	<i>16</i>
<i>Figure 8: BSC7 Seismic Motion, m/rtHz.....</i>	<i>19</i>
<i>Figure 9: BSC ISI Optics Table Seismic Motion and ISI Stage 0, m/rtHz.....</i>	<i>19</i>
<i>Figure 9: Scattered Light Displacement Noise: ITM Elliptical Baffle.....</i>	<i>25</i>

#### Table of Tables

<i>Table 1: ITM Elliptical Baffle Characteristics.....</i>	<i>14</i>
--	-----------

# 1 INTRODUCTION

## 1.1 Scope

This document provides the final design for the ITM Elliptical Baffle.

The FM Beam Dump, FM Elliptical Baffle, and Manifold Flat Baffle were eliminated as a result of the decision to eliminate H2 and build a 3rd interferometer in the same configuration as H1 and L1.

## 1.2 Final Design Review Checklist

### 1.2.1 Final requirements – any changes or refinements from PDR?

The requirements for the ITM Elliptical baffle are listed in [T070061](#) Stray Light Control Design Requirements. These baffles and beam dumps fall into the general category of Cavity Beam Dumps, and must meet the vignetting requirements specified in Sec. 4.8.

#### Direct Requirements

Phase noise due to scattered light fields injected into the interferometer is treated as a technical noise source. Therefore, the total scattered light phase noise, expressed in equivalent displacement noise, must be  $< 1/10^{\text{th}}$  of the quadrature sum of the suspension thermal noise and the test mass thermal noise (referred to as the SRD), as given in Figure 1 of [M060056-06](#), Advanced LIGO Reference Design.

#### ITM Elliptical Baffle Requirements

The ITM Elliptical Baffle shall block the IFO beam that passes from the PR3 mirror around the edges of the BS mirror. It shall form an elliptical aperture of a specified minor and major diameter that allows passage of the power recycling cavity beam from the BS mirror to the ITM mirror. It shall block the arm cavity beam exiting through the ITM AR face that exceeds the size of the elliptical aperture.

#### New: Clear Aperture Requirements

See RODA [M1200268-v2](#)

The analysis of noise from the ITM elliptical baffle due to vibration of the baffle and consequent clipping of the beam led to the following proposed solution -- a pair of BS elliptical baffles which have the system aperture and increasing the aperture of the ITM elliptical baffles. The write up can be found at [LIGO-G1200467-v2](#).

The ITM Elliptical Baffle will provide an elliptical aperture of 224 mm horizontal diameter and 274 mm vertical diameter. No power loss will occur in the recycling cavity provided the elliptical aperture is positioned to within  $< 7\text{mm}$  of the recycling cavity beam centerline.

### 1.2.2 Resolutions of action items from SLC PDR

Refer to: [LIGO-L0900119-v1](#)

#### Lower BRDF Material for Baffles

We suggest the team consider a lower-BRDF material for the more critical baffles; and in particular, suggest looking at the electro-static frit black-enameled steel as an option

that would give better optical performance.

**Ans:** *The lowest BRDF material that is practical at the moment is oxidized polished stainless steel.*

### 1.2.3 Final Parts Lists and Drawing Package

[D1003238-v2](#) aLIGO AOS ITM ELLIPTICAL BAFFLE FINAL ASSY

[E1101039-v1](#) BOM\_aLIGO AOS ITM ELLIPTICAL BAFFLE FINAL ASSY

### 1.2.4 Final specifications

[E0900023-v11](#) PROCESS FOR MANUFACTURING CANTILEVER SPRING BLADES FOR AdvLIGO

[E0900364-v8](#) Metal components intended for use in the Adv LIGO Vacuum System

[E1100842](#) Specification for Mirror Finished (Super #8) Stainless Steel to be used in the LIGO Ultra-High Vacuum System

### 1.2.5 Final interface control documents

The mechanical and optical interfaces of the ITM ELLIPTICAL BAFFLE are described in:

[D0901142-v4](#) AdvLIGO Systems, BSC2-H1 Top Level Chamber Assembly

[D0900428-v5](#) AdvLIGO Systems, BSC2-L1 Top Level Chamber Assembly

[D0900525-v2](#) AdvLIGO SUS BSC2-L1, XYZ Local CS for Elliptical Baffle (ITMX,ITMY)

### 1.2.6 Relevant RODA changes and actions completed

*Not applicable*

### 1.2.7 Signed Hazard Analysis

[E1101018-v1](#) SLC ITM Elliptical Baffle Install Hazard Analysis

### 1.2.8 Final Failure Modes and Effects Analysis

*Not Required*

### 1.2.9 Risk Registry items discussed

*None for this subsystem*

### 1.2.10 Design analysis and engineering test data

See Section 3 Descriptions of Baffles and Section 4 Scattered Light Displacement Noise

### 1.2.11 Software detailed design

*Not applicable*

### 1.2.12 Final approach to safety and use issues

[E1101018](#) SLC ITM Elliptical Baffle Install Hazard Analysis

### **1.2.13 Production Plans for Acquisition of Parts, Components, Materials Needed For Fabrication**

[E1101002 ITM Elliptical Baffle Production Plan](#)

### **1.2.14 Installation Plans and Procedures**

[E1101021 ITM Elliptical Baffle Installation Procedure](#)

*This will be deferred until after FDR*

### **1.2.15 Final hardware test plans**

- Blade stiffness measurement

See [E1000892 Arm Cavity Baffle Fabrication, Installation, and Test Plan](#)

- Other Testing

See [E1101021 ITM Elliptical Baffle Installation Procedure](#)

### **1.2.16 Final software test plans**

Not applicable.

### **1.2.17 Cost compatibility with cost book**

See [E1101002 ITM Elliptical Baffle Production Plan](#)

### **1.2.18 Fabrication, installation and test schedule**

See [E1101022 ITM Elliptical Baffle Fabrication and Installation Test Plan](#)

### **1.2.19 Lessons Learned Documented, Circulated**

### **1.2.20 Porcelainizing**

The baffles will be constructed of oxidized polished stainless steel to avoid shedding of the porcelain surface.

### **1.2.21 Problems and concerns**

There are presently no known problems or concerns with the recycling cavity baffles.

## **1.3 Applicable Documents**

[T070303 Arm Cavity Finesse for aLIGO](#)

[T070247 aLIGO ISC Conceptual Design](#)

[E0900364-v8 LIGO Metal in Vacuum](#)

[T060073-00 Transfer Functions of Injected Noise](#)

[T070061-v2 Stray light Control Design Requirements](#)

[T0900269-v2 Stray Light Control \(SLC\) Preliminary Design](#)

[T1100056-v2 Arm Cavity Baffle Edge Scatter](#)[T1100446-v1](#) ITM Elliptical Baffle FD[D1003238-v2](#) aLIGO AOS ITM ELLIPTICAL BAFFLE FINAL ASSY[E1101022](#) ITM Elliptical Baffle Fabrication and Installation Test Plan[E1101021](#) SLC ITM Elliptical Baffle Installation Procedure[E1101018](#) SLC ITM Elliptical Baffle Install Hazard Analysis[E1101002](#) ITM Elliptical Baffle Production Plan[T070061](#) AOS: Stray Light Control (SLC) Design Requirements[D0900428-v5](#) AdvLIGO Systems, BSC2-L1 Top Level Chamber Assembly[D0900525-v2](#) AdvLIGO SUS BSC2-L1, XYZ Local CS for Elliptical Baffle (ITMX,ITMY)[D0901142-v4](#) AdvLIGO Systems, BSC2-H1 Top Level Chamber Assembly[D0900481-v4](#) AdvLIGO Systems, BSC4-H2 Top Level Chamber Assembly[D1002413-v1](#) AdvLIGO SUS BSC4-H2, XYZ Local CS for Elliptical Baffle (ITMX,ITMY)[M1200268-v2](#) RODA: Decision to accept the elliptical baffle assembly on the BS suspension structure[T1000090-v5](#) aLIGO Baffle Design using SIS[T1300324-v1](#) ITM Elliptical Baffle Scatter



## 2 BAFFLE DESCRIPTIONS

### 2.1 FUNCTION

#### 2.1.1 ITM ELLIPTICAL BAFFLE

The ITM Elliptical Baffles catch some of the ghost beams from the ITM and Compensation plate, and the light entering the power recycling cavity from the ITM mirror that would spill around the BS. The elliptical hole in the ITM Elliptical Baffle is slightly larger than the hole in the BS Elliptical baffle that defines the profile of the beams inside the power recycling and signal recycling cavities and therefore will not vignette the recycling cavity beams.

#### 2.2 H1 & L1 IFO ZEMAX LAYOUT

The H1 & L1 IFO ZEMAX layout of BSC2 is shown in Figure 1.

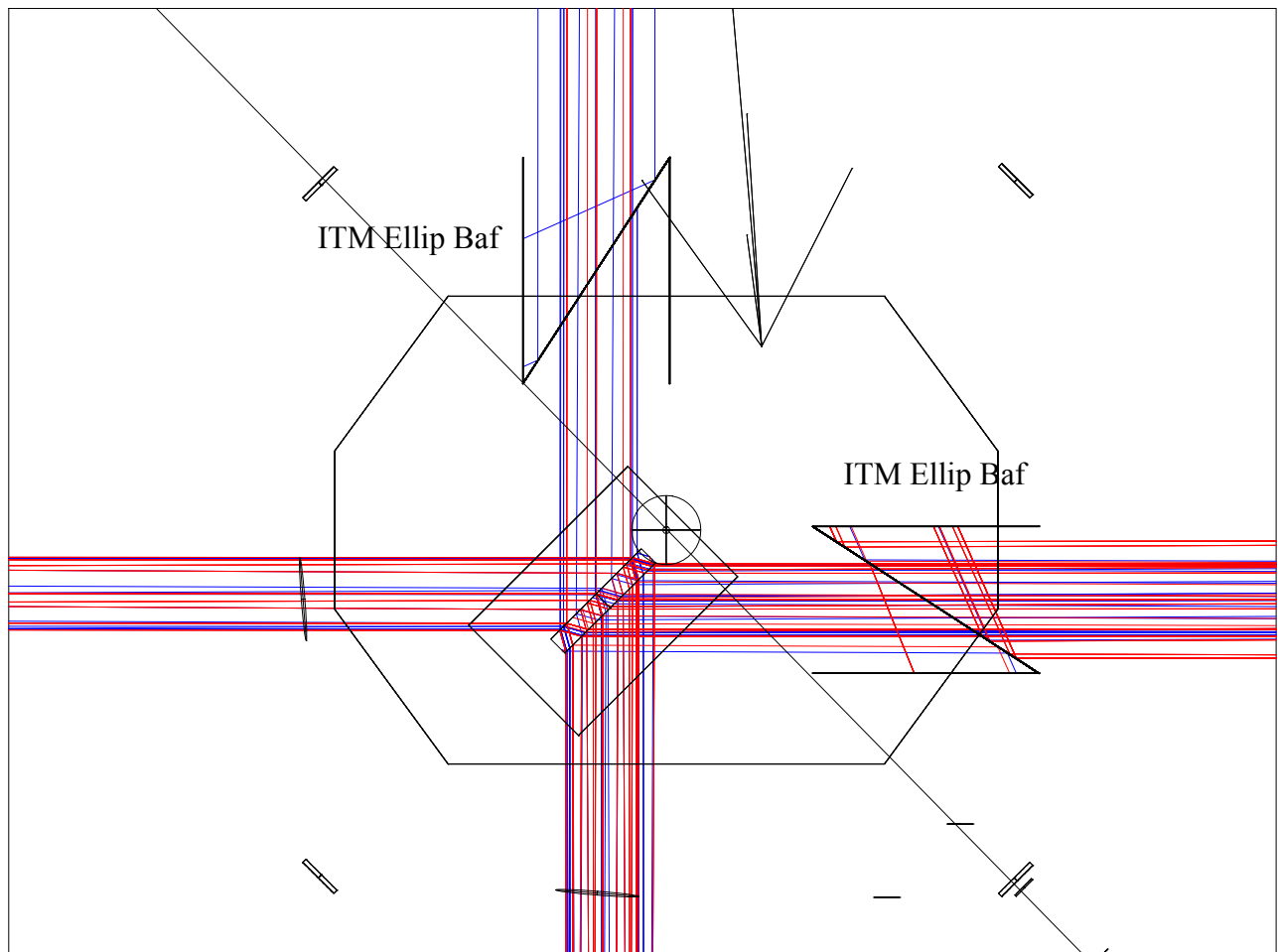

Figure 1: BSC2: ITM Elliptical Baffles

### 3 DESCRIPTIONS OF BAFFLES

#### 3.1 SUSPENSION

##### 3.1.1 Transmissibility Measurements

The ITM Elliptical Baffle uses a similar suspension structure as the Arm Cavity Baffle (ACB). A preliminary measurement of the suspended ITM Elliptical Baffle longitudinal transmissibility is shown in Figure 2.

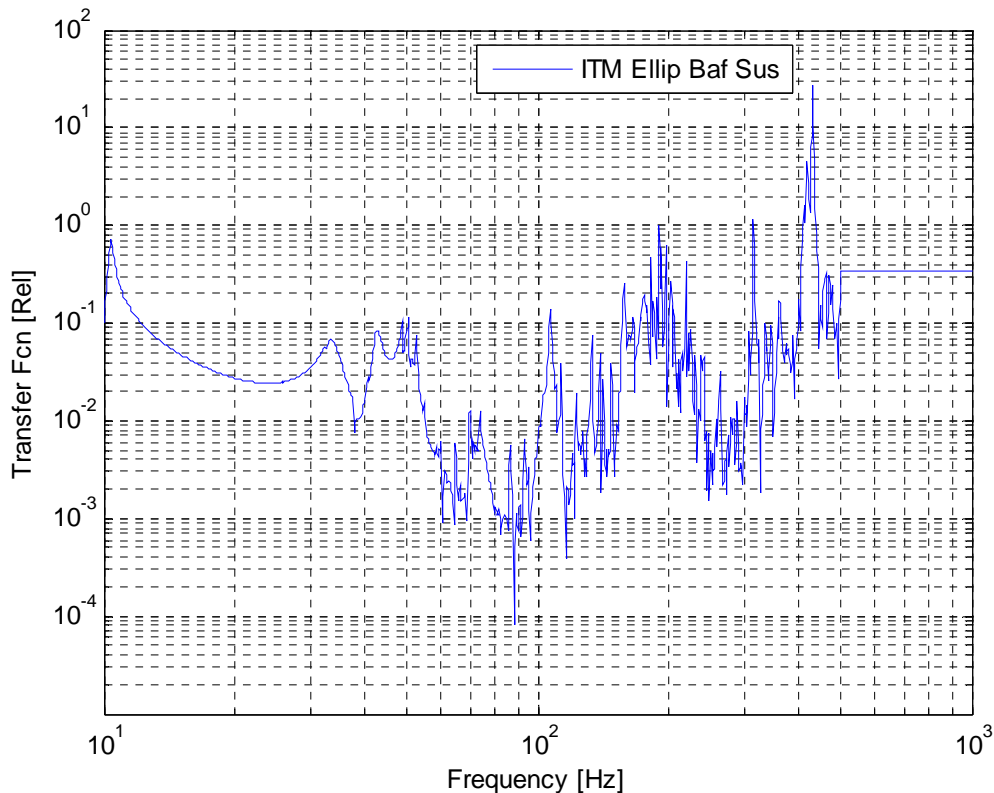

**Figure 2: Preliminary Longitudinal Transmissibility of ITM Elliptical Baffle Suspension**

##### 3.1.2 Stray Magnetic Field Measurement

Two eddy current damper magnets will be used for the ITM Elliptical Baffle, and they will be placed  $> 0.7\text{m}$  distance from the magnets of the TM SUS magnets of the BS. The effect of the eddy current magnetic field on the TM SUS is negligible; see [T1000738 SLC Magnetic Field Measurements of the Eddy Current Damper](#).

##### 3.1.3 Earthquake Stops

The earthquake stops consist of travel-limiting rods mounted to the large down-tube that holds the eddy-current copper damping plates, which mount to the ISI Stage 0, as shown in Figure 3 (note:

the photodetector cables are part of the ACB and are not used for the ITM Elliptical baffle). The rods restrain the excess motion of the suspended baffle in three axes.

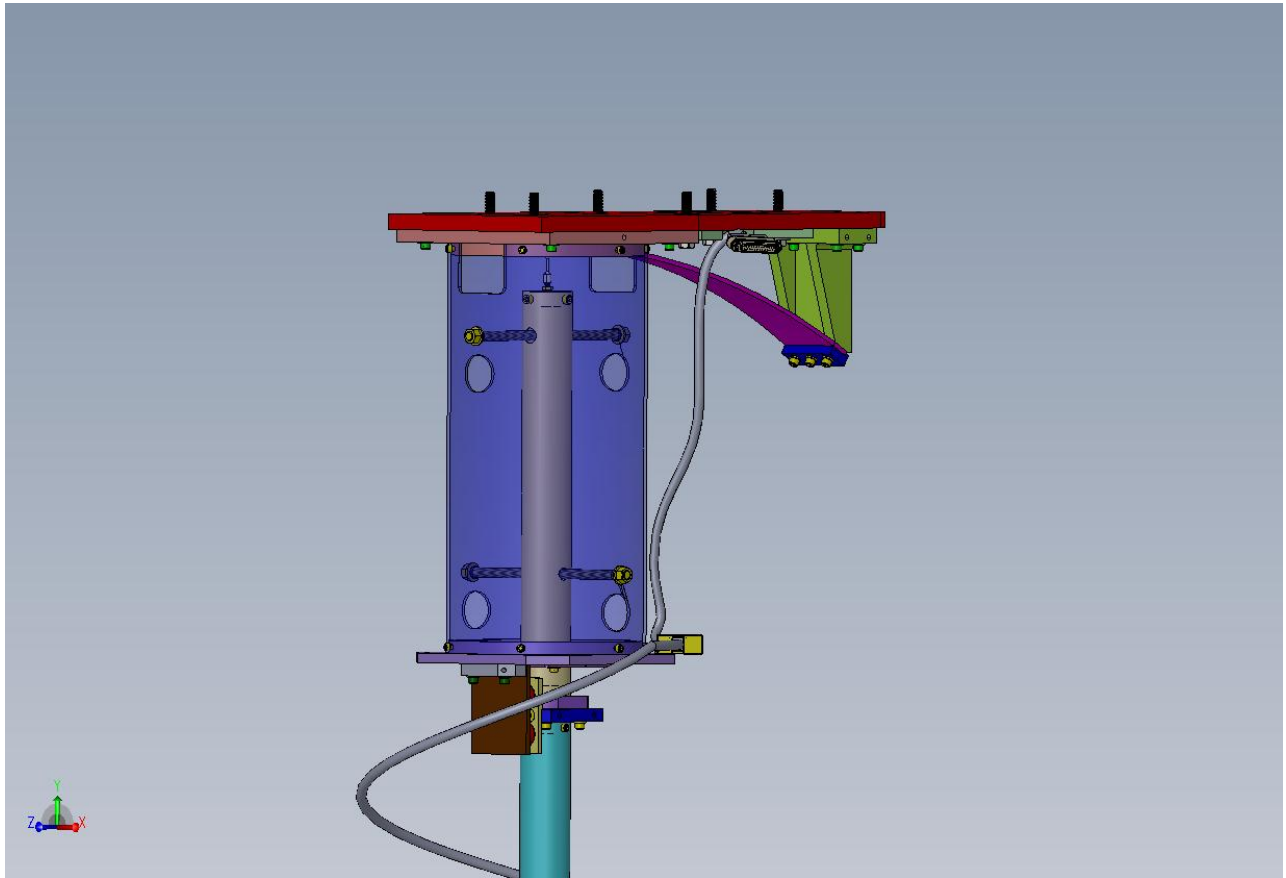

**Figure 3: Earthquake Stops**

### 3.1.4 Eddy Current Damping

The eddy current damping mechanism has permanent magnets mounted to the down tube of the baffle that move against a copper plate, which is fixed to the outer tube that is rigidly mounted to the upper stage 0 structure; see Figure 4. The currents induced in the copper plate dissipate the energy of motion of the baffle.

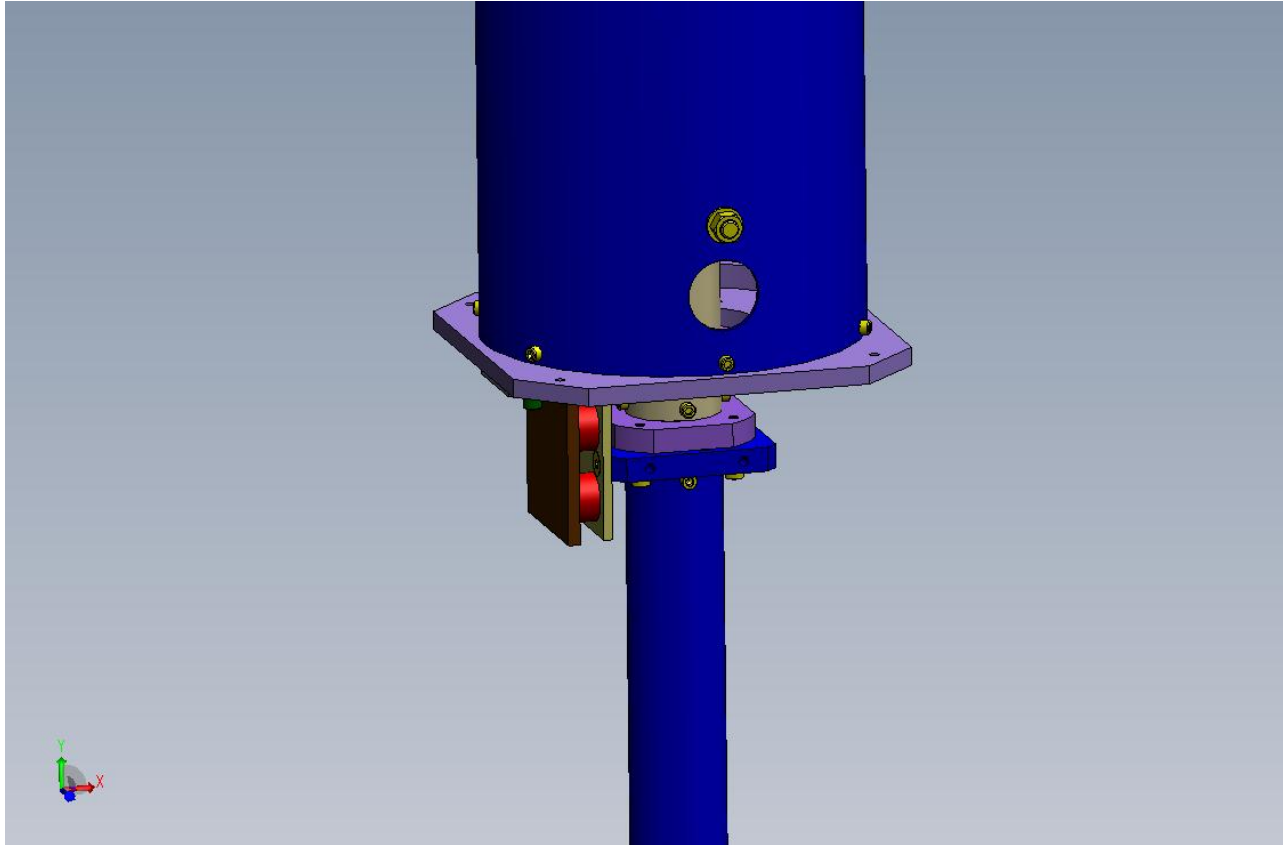

**Figure 4: Eddy Current Damping Apparatus**

### 3.2 ITM ELLIPTICAL BAFFLE

The ITM Elliptical Baffle is suspended from the ISI Stage 0 by a vertical blade spring and pendulum flexure, as shown in Figure 5.

The motion of the suspended baffle is damped in six degrees of freedom by the eddy current damping apparatus.

The size of the ITM Elliptical Baffle baffle hole was chosen to be 7mm larger on all sides than the limiting aperture of the BS Elliptical Baffle, 210 x 260 mm--Ref: [T1000090-v5](#), aLIGO Baffle Design using SIS.

The center of the baffle hole with respect to the recycling cavity beam axis is determined by sighting with a theodolite on a temporary target placed at the center of the ITM Elliptical Baffle hole. The lateral (horizontal) position of the baffle hole is adjusted by shifting the position of the interface plate mounted to Stage 0; the vertical height of the baffle is adjusted by changing the length of the vertical suspension tube.



**Figure 5: ITM Elliptical Baffle**

### **3.2.1 ITM Elliptical Baffle Vibration Analysis**

### 3.2.2 ITM Elliptical Baffle Physical Characteristics

The physical characteristics of the ITM Elliptical Baffle are shown in Table 1.

**Table 1: ITM Elliptical Baffle Characteristics**

Parameter	Value
Location	BSC2
Suspension	Vertical blade spring, flex-wire pendulum, eddy-current damping
Global Height	-89.5 mm
Aperture diameter along beam axis	234 mm horizontal, 274 mm vertical
Material	Oxidized polished stainless steel
BRDF	<0.03 sr <sup>-1</sup>
Weight	99 lbs

## 3.3 OPTICAL INTERFACES

### 3.3.1 ITM Elliptical Baffle

The ITM elliptical baffle will be aligned to within +/- 0.5 mm of the global beam line by means of sighting with the theodolite on a target placed at the center of the baffle hole.

The elliptical horizontal radius will change by approx +/- 3 mm for each 1 deg of baffle rotation. The baffle can be rotated approximately 4 deg before clipping of the recycling cavity beam occurs. The baffle will be aligned within 2 deg of the beam tube axis by using alignment tooling during the assembly and installation process.

The BS Elliptical Baffle is the limiting aperture for the recycling cavity beam and motion of the ITM Elliptical Baffle will not modulate the recycling cavity beam.

## 4 SCATTERED LIGHT DISPLACEMENT NOISE

### 4.1 Scattered Light Requirement

A DARM signal is obtained when the differential arm length is modulated as a result of a gravity wave strain. The DARM signal was calculated in reference, T060073-00 Transfer Functions of Injected Noise, and is defined by the following expression:

$$V_{\text{signal}} = \text{DARM} \cdot L \cdot h_{\text{SRD}} \cdot \sqrt{P_0}$$

Where  $L$  is the arm length,  $h_{\text{SRD}}$  is the minimum SRD gravity wave strain spectral density requirement,  $P_0$  is the input laser power into the IFO, and DARM is the signal transfer function.

In a similar manner, an apparent signal (scattered light noise) occurs when a scattered light field with a phase shift is injected into the IFO at some particular location, e.g. through the back of the ETM mirror. The scattered light noise is defined by the following expression:

$$V_{\text{noise}} := \text{SNXXX} \cdot \delta_{\text{SN}} \cdot \sqrt{P_{\text{SNi}}}$$

$P_{\text{SNi}}$  is the scattered light power injected into the IFO mode,  $\delta_{\text{SN}}$  is the phase shift of the injected field, and SNXXX is the noise transfer function for that particular injection location.

The phase shift spectral density of the injected field due to the motion of the scattering surface is given by

$$\delta_{\text{SNi}} := \frac{4 \cdot \pi \cdot x_s}{\lambda}$$

where  $x_s$  is the spectral density of the longitudinal motion of the scattering surface.

In general, the different scattering sources are not coherent and must be added in quadrature. The requirement for total scattered light displacement noise can be stated with the following inequality:

$$\sqrt{\sum_{i=1}^n \left( \frac{\text{SNXXX}}{\text{DARM}} \cdot \frac{4 \cdot \pi \cdot x_s}{\lambda} \cdot \sqrt{\frac{P_{\text{SNi}}}{P_0}} \right)^2} < \frac{1}{10} \cdot L \cdot h_{\text{SRD}}$$

The SNXXX/DARM scattered light noise transfer function ratios for various injection locations within the IFO are shown in Figure 6: Scattered Light Noise Transfer Functions.

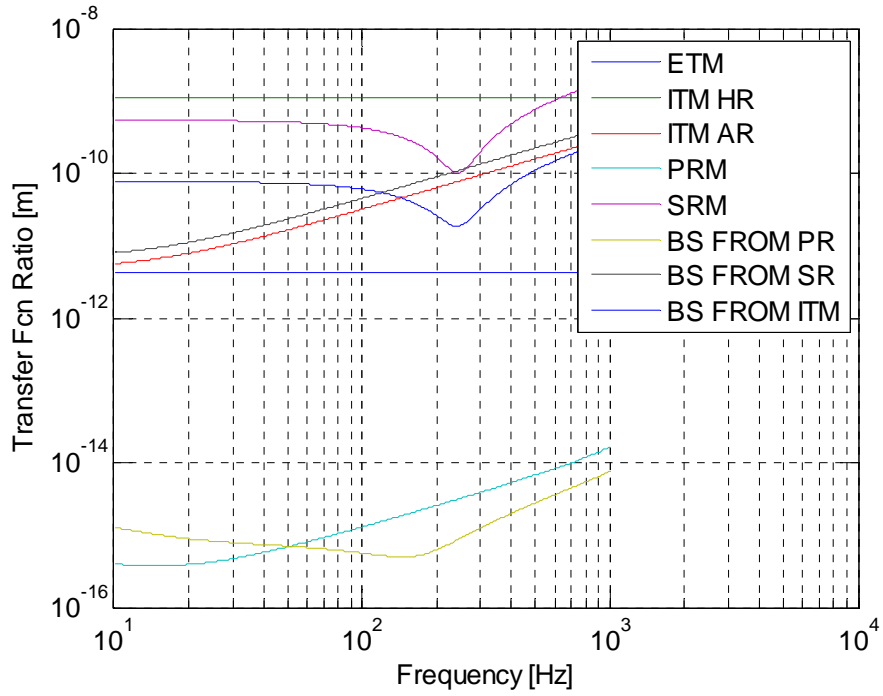

Figure 6: Scattered Light Noise Transfer Functions

### 4.2 Scattered Light Parameters

BRDF, sr<sup>-1</sup>; CSIRO, surface 2, S/N 2

$$BRDF_1(\theta) := \frac{2755.12}{\left(1 + 8.5078710^8 \cdot \theta^2\right)^{1.23597}}$$

incidence angle at COC, rad

$$\theta_{coc} := \frac{120}{4 \cdot 10^6} \quad \theta_{coc} = 3 \times 10^{-5}$$

BRDF of ellip baf, sr<sup>-1</sup>

$$BRDF_{ellbaf} := 0.030$$

BRDF of edge, sr<sup>-1</sup>

$$BRDF_{edge} := 0.1$$

BRDF of BD, sr<sup>-1</sup>

$$BRDF_{bd} := 0.030$$

BRDF of chamber wall, sr<sup>-1</sup>

$$BRDF_{wall} := 0.1$$

Motion of suspended baffle @ 100 Hz, m/rt Hz

$$x_{baf} := 1 \cdot 10^{-12}$$

Motion of BSC chamber @ 100 Hz, m/rt Hz

$$x_{bscchamber} := 2 \cdot 10^{-11}$$



laser wavelength, m	$\lambda := 1.06410^{-6}$	
wave number, m <sup>-1</sup>	$k := 2 \cdot \frac{\pi}{\lambda}$	$k = 5.9052 \times 10^6$
Transfer function @ 100 Hz, ITM AR	$TF_{itmar} := 3.16 \cdot 10^{-11}$	
Transfer function @ 100 Hz, BS from ITM	$TF_{bsitm} := 6.0 \cdot 10^{-11}$	
ITM beam radius, m	$w_{itm} := 0.05316$	
transformed beam waist after ITM AR surface (see H1 Signal Recycling Cavity beam size_8-12-13)	$w_{itmar0} := 0.00834$	
solid angle of ITM AR beam waist, sr	$\Delta_{itmar} := \pi \cdot \left( \frac{\lambda}{\pi \cdot w_{itmar0}} \right)^2$	
	$\Delta_{itmar} = 5.1784 \times 10^{-9}$	
elliptical baffle minor semi-axis, m	$a := \frac{0.21 + 0.014}{2} + 0.007$	$a = 0.119$
elliptical baffle major semi-axis, m	$b := \frac{0.260 + 0.014}{2} + 0.007$	$b = 0.144$
Reflectivity of Elliptical Baffle	$R_{ellbaf} := 2.4e-5$	
Transmissivity of ITM HR	$T_{itmhr} := 0.014$	
<b>Ref. T070247</b>		
input laser power, W	$P_{psl} := 125$	
arm cavity gain	$G_{ac} := 1300$	
arm cavity power, W	$P_a := \frac{P_{psl}}{2} \cdot G_{ac}$	$P_a = 8.125 \times 10^5$

**Ref. Hiro e-mail 8/29/11**

power in power recycling cavity arm, W	$P_{\text{rca}} := \frac{P_a \cdot T_{\text{itmhr}}}{4}$	$P_{\text{rca}} = 3.08 \times 10^3$
Gaussian power parameter in recycling cavity	$P_{0\text{rc}} := 3.08 \times 10^3$	
radius of ITM, mm	$r_{\text{itm}} := 0.17c$	
exitance function from ITM	$I_{\text{itm}}(x,y) := 2 \cdot \frac{4 \cdot P_{0\text{rc}}}{\pi \cdot w_{\text{itm}}^2} \cdot e^{-2 \cdot \left( \frac{x^2 + y^2}{w_{\text{itm}}^2} \right)}$	

**4.2.1 BRDF of Baffle Surfaces**

The baffle surfaces are oxidized polished stainless steel, with a measured BRDF  $< 0.03 \text{ sr}^{-1} @ > 5$  deg incidence angle.

**4.2.2 BSC Seismic Motion**

The seismic motion spectrum of the BSC walls is shown in Figure 7. The motion spectrum of the ISI Stage 0 is shown in Figure 8.

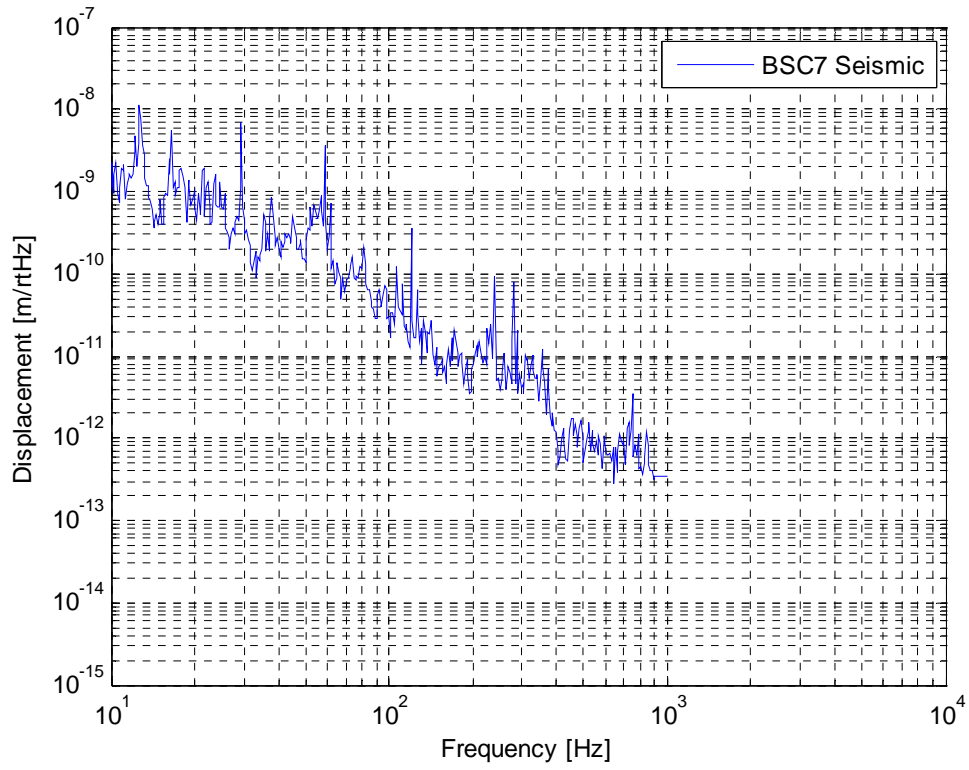

Figure 7: BSC7 Seismic Motion, m/rtHz

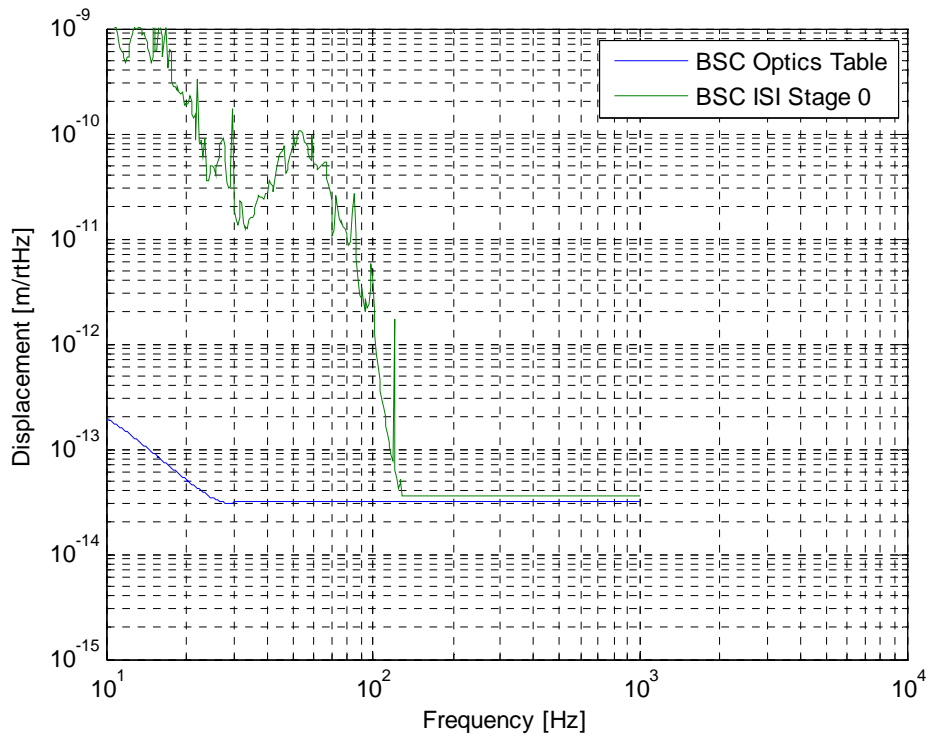

Figure 8: BSC ISI Optics Table Seismic Motion and ISI Stage 0, m/rtHz

### 4.3 ITM Elliptical Baffle

#### 4.3.1 ITM Elliptical Baffle Suspension Transmissibilities

The motion transmissibilities of the suspended ITM Elliptical Baffle are presented in the following.

The X data is in the horizontal direction and transverse to the recycling cavity beam axis; the Y data is in the vertical direction and transverse to the recycling cavity beam axis; the Z data is in the horizontal direction and parallel to the recycling cavity beam axis.

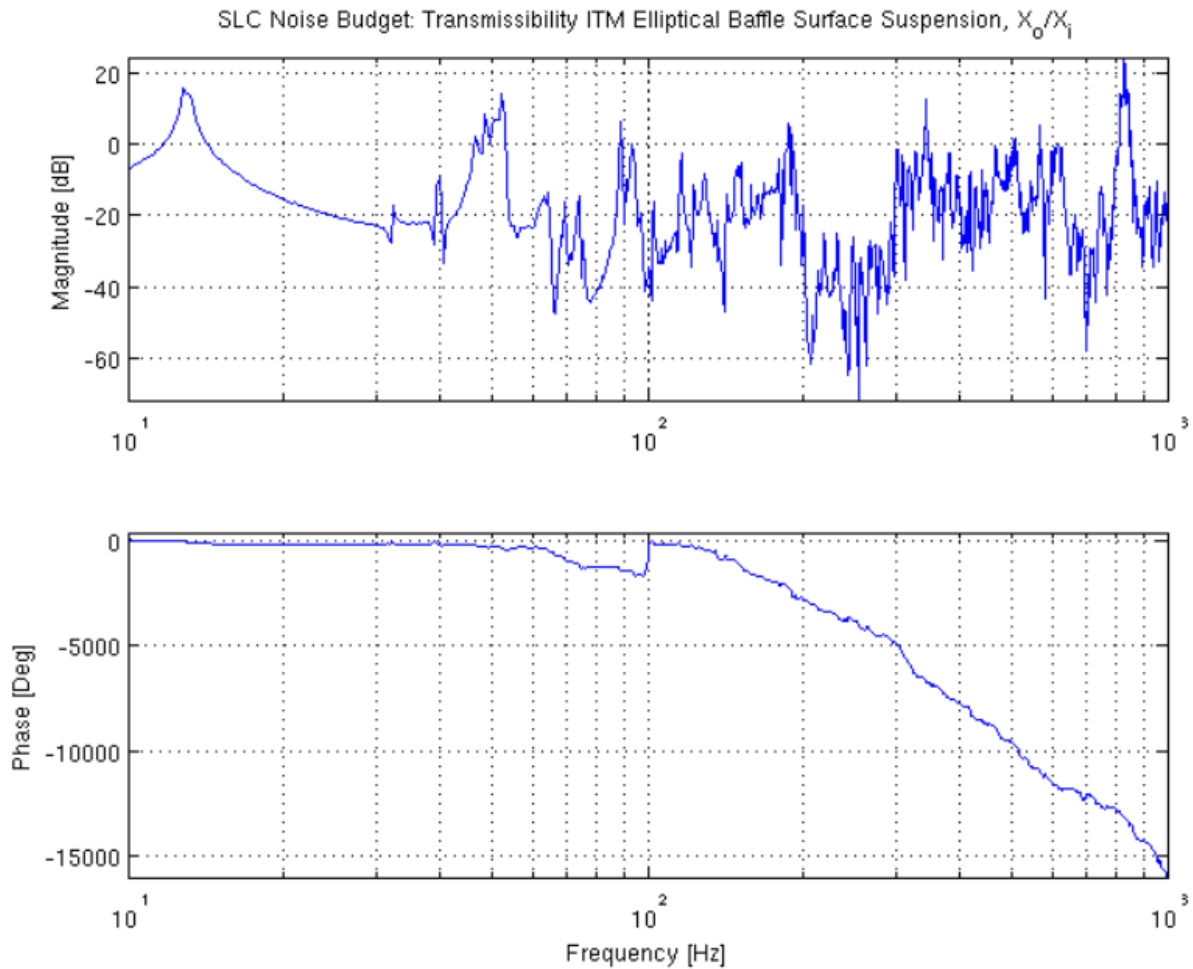

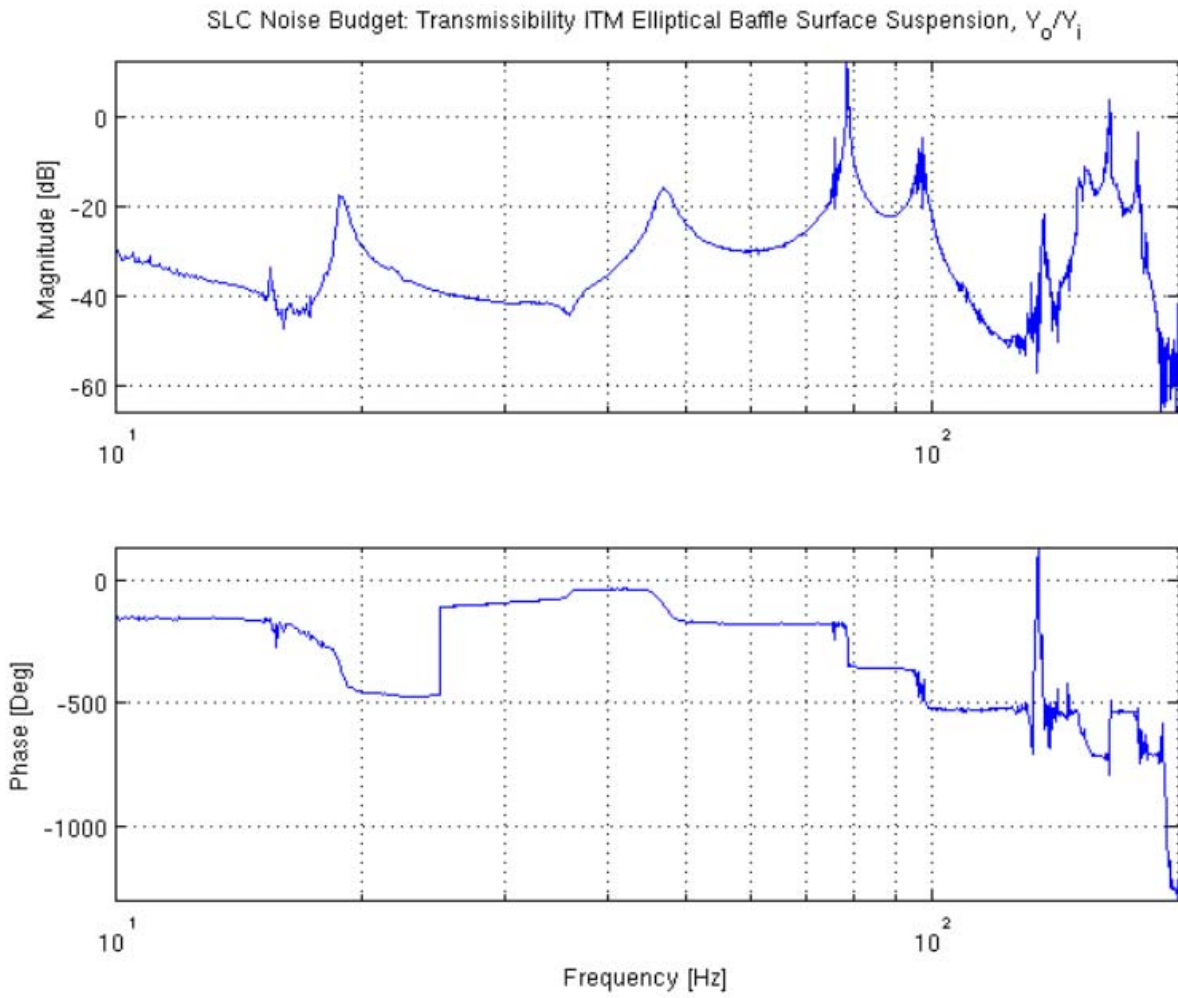

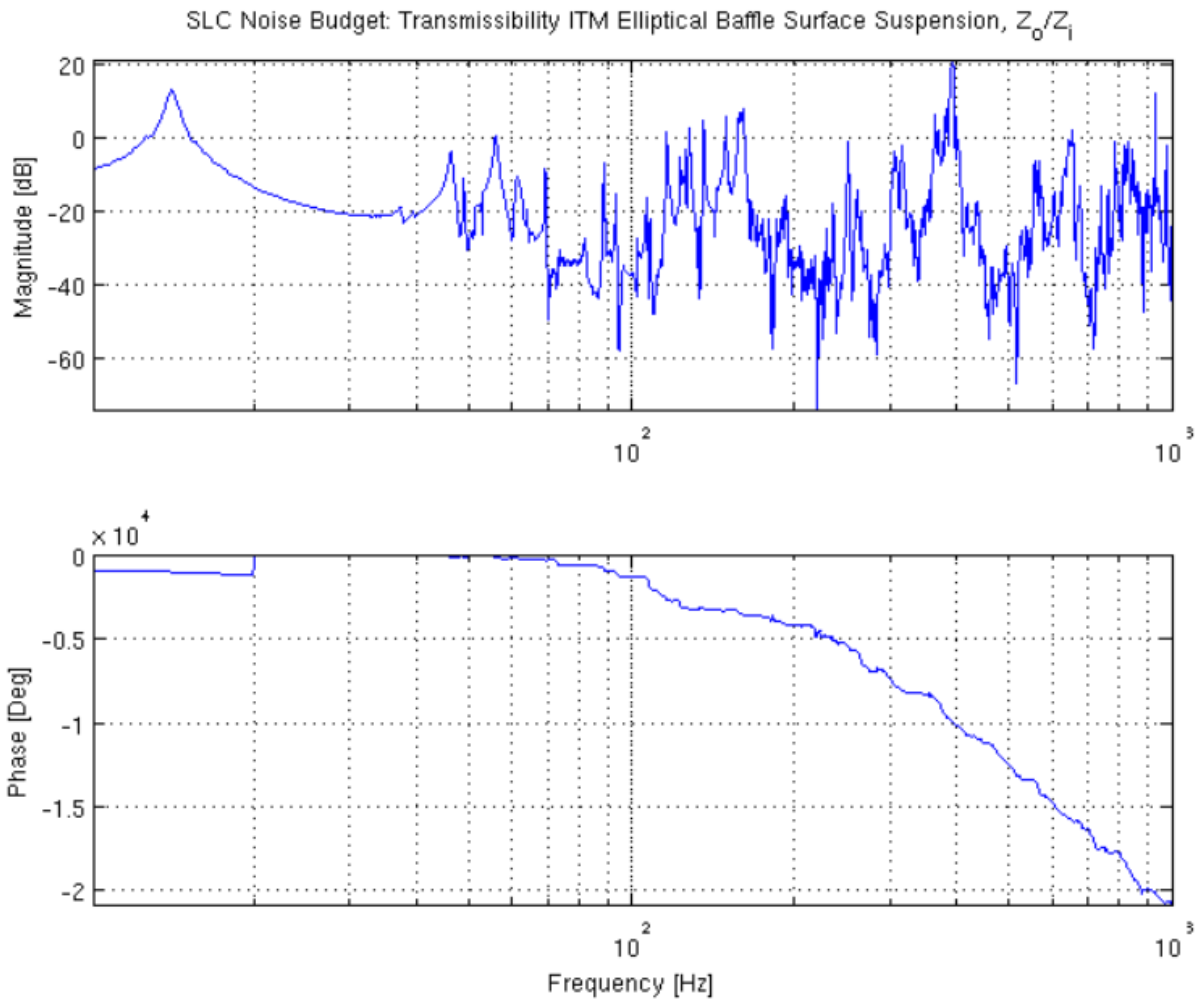

### 4.3.2 ITM Elliptical Baffle Scatter

power exiting from ITM toward elliptical baffle, W

$$P_{itm} := 4 \int_0^{r_{itm}} \int_0^{\sqrt{1 - \frac{y^2}{r_{itm}^2}}} I_{itm}(x, y) dx dy$$

$$P_{itm} = 1.1375 \times 10^4$$

power hitting the ITM elliptical baffle  
from ITM side

$$P_{itmellbaf} = 0.164$$

Power scattered into IFO mode  
from both arms, W

$$P_{itmellbafs} := \sqrt{2} \cdot P_{itmellbaf} \cdot BRDF_{ellbaf} \cdot \Delta_{itmar}$$

$$P_{itmellbafs} = 3.6025 \times 10^{-11}$$

The horizontal Transmissivity of the ACB baffle (see Figure 2 ) will be used as an estimate of the horizontal transmissibility of the ITM Elliptical baffle.

displacement noise @ 100 Hz, m/rtHz

$$DN_{itmellbaf} := TF_{itmar} \cdot \left( \frac{P_{itmellbafs}}{P_{psl}} \right)^{0.5} \cdot x_{baf} \cdot \frac{2}{\sqrt{2}} \cdot k$$

$$DN_{itmellbaf} = 4.2502 \times 10^{-24}$$

### 4.3.3 ITM Elliptical Baffle Reflection, Scatter from Walls

A fraction of the light that hits the elliptical baffle surface will reflect from the baffle, hit and scatter from the chamber walls, then reflect again from the baffle and enter the mode of the IFO.

Power reflected from baffle, W

$$P_{itmellbafrefl} := R_{ellbaf} \cdot P_{itmellbaf}$$

$$P_{itmellbafrefl} = 3.9354 \times 10^{-6}$$

Power scattered into IFO mode  
from both arms, W

$$P_{itmellbafrefls} := \sqrt{2} \cdot P_{itmellbafrefl} \cdot R_{ellbaf} \cdot BRDF_{wall} \cdot \Delta_{itmar}$$

$$P_{itmellbafrefls} = 6.9168 \times 10^{-20}$$

### 4.3.4 ITM Elliptical Baffle Hole Edge Scatter

The edge of the ITM elliptical baffle hole causes excess scattered light displacement noise, as will be shown in the following, unless it is beveled to hide the exposed edge.

thickness of baffle plate, m

$$t := 0.047 \cdot 0.0254$$

Radius of baffle hole, m

$$R_{itmbaf} := 0.105$$

tilt angle of ITM ellip baffle, deg

$$\theta_{itmbaf} := 57$$

maximum width of exposed edge, m

$$w_{itmbafe} := t \cdot \sin\left(\theta_{itmbaf} \cdot \frac{\pi}{180}\right)$$

$$w_{itmbafe} = 1.0012 \times 10^{-3}$$

exposed area of baffle hole edge, m<sup>2</sup>

$$A_{itmbafe} = 2.2427 \times 10^{-4}$$

exitance function from ITM at edge,  
W/m<sup>2</sup>

$$I_{itm}(x, y) := 2 \cdot \frac{4 \cdot P_{0rc}}{\pi \cdot w_{itm}^2} \cdot e^{-2 \cdot \left(\frac{x^2 + y^2}{w_{itm}^2}\right)}$$

power incident on ITM Baf hole edge, W

$$I_{itm}(x, y) = 358.2562$$

$$P_{itmbafedge} := I_{itm}(x, y) \cdot A_{itmbafe}$$

$$P_{itmbafedge} = 0.027$$

power scattered from two ITM Ellip Baf hole edge toward ITM, W

$$P_{itmbafedges} := \sqrt{2} \cdot P_{itmbafedge} \cdot BRDF_{edge} \cdot \Delta_{itmar}$$

$$P_{itmbafedges} = 1.9914 \times 10^{-11}$$

displacement noise @ 100 Hz, m/rtHz

$$DN_{itmbafedge} := TF_{itmar} \cdot \left(\frac{P_{itmbafedges}}{P_{psl}}\right)^{0.5} \cdot x_{baf} \cdot \frac{2}{\sqrt{2}} \cdot k$$

$$DN_{itmbafedge} = 3.16 \times 10^{-24}$$



The ITM elliptical baffle exposed hole edge contributes a significant amount of scattered light noise, as seen in the calculated ratio, and therefore will be beveled to hide the edge.

ratio of edge scatter to baf scatter  $\frac{DN_{itm\ baf\ edge}}{DN_{itm\ ell\ baf}} = 0.7435$

#### 4.4 Scattered Light Displacement Noise Summary

A plot of the calculated scattered light displacement noise spectrum for the ITM Elliptical Baffle is shown in Figure 9.

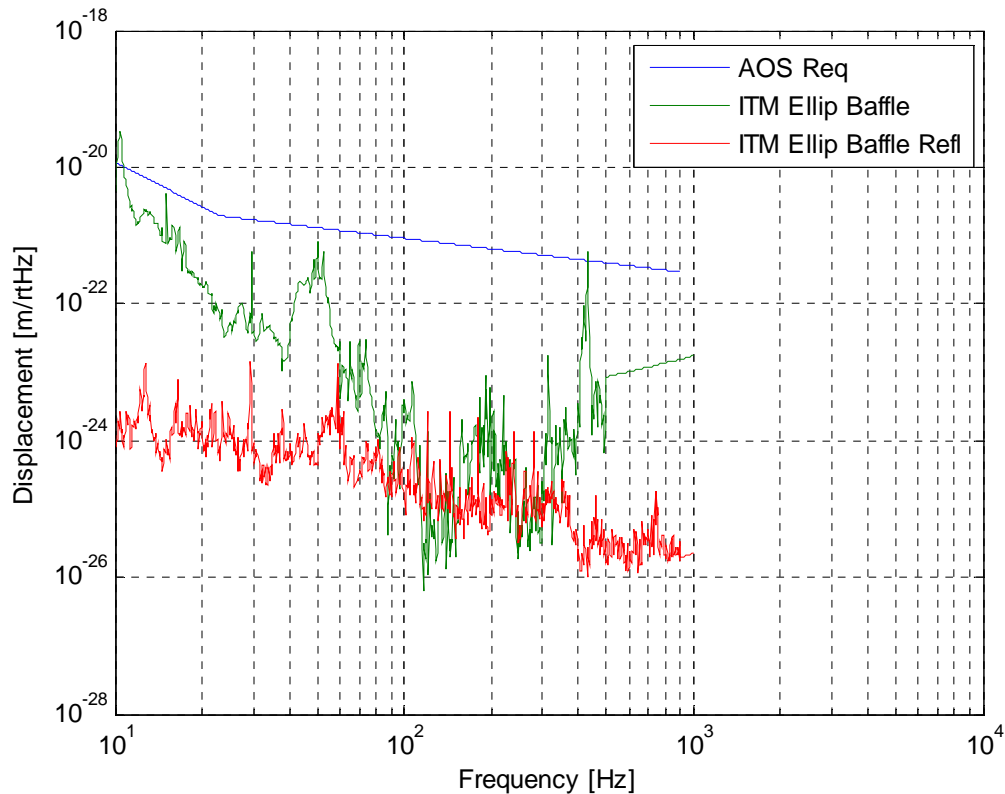

**Figure 9: Scattered Light Displacement Noise: ITM Elliptical Baffle**

## 5 INTERFACE CONTROL DOCUMENT

The mechanical and optical interfaces of the ITM Elliptical Baffle described in the following documents.

[D0900428-v5](#) AdvLIGO Systems, BSC2-L1 Top Level Chamber Assembly

[D0900525-v2](#) AdvLIGO SUS BSC2-L1, XYZ Local CS for Elliptical Baffle (ITMX,ITMY)  
[D0901142-v4](#) AdvLIGO Systems, BSC2-H1 Top Level Chamber Assembly