

REV.	DATE	DCN #	DRAWING TREE #
v1	04 DEC 2013	-	-
v2	08 APR 2014	E1300890-x0	-
-	-	-	-

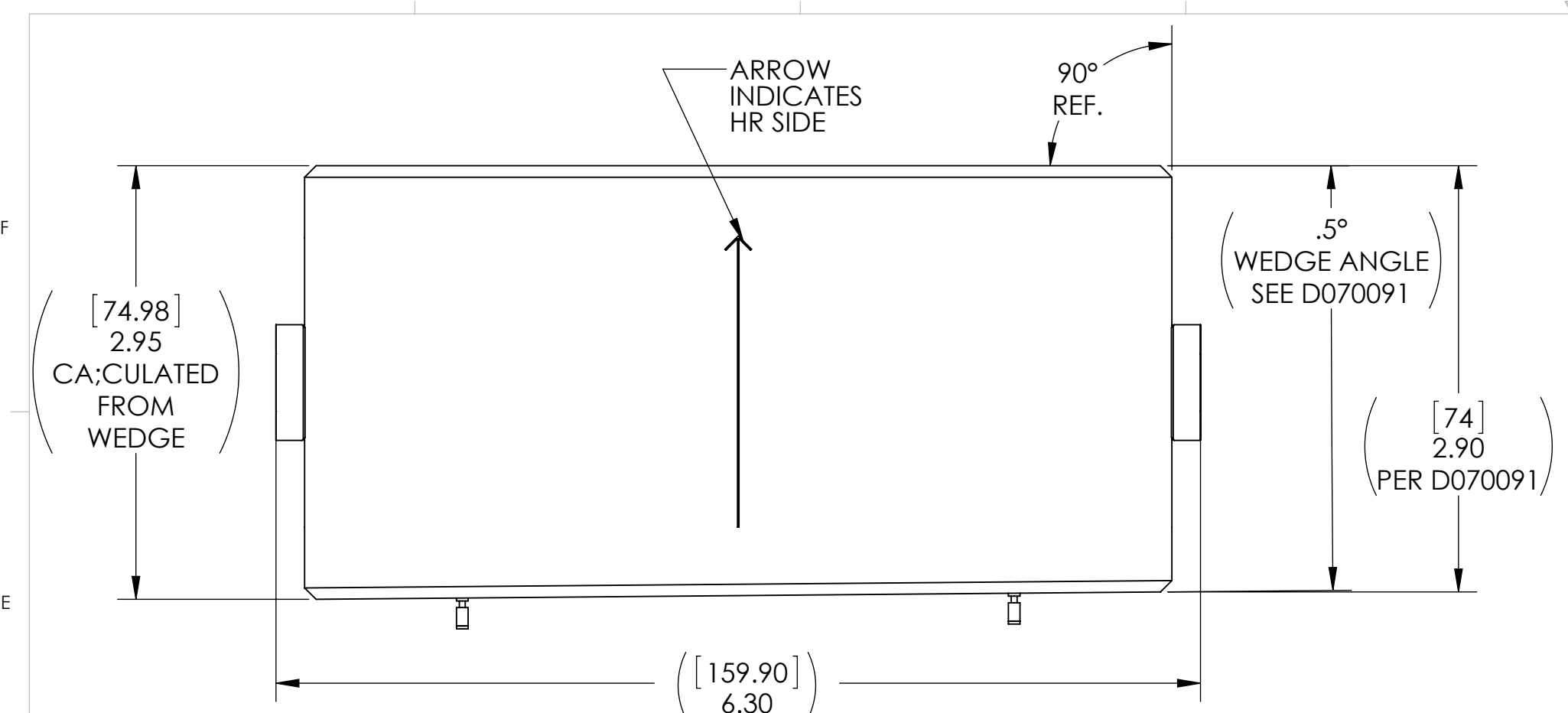

- NOTES:
- REFER TO LIGO E1200211 FOR PRISM GLUING PROCEDURE
 - SEE LIGO E990196 FOR MAGNET/ STANDOFF ASSEMBLY PROCEDURE
 - FOR MAGNET /STANDOFF TO OPTIC GLUING PROCEDURE, SEE E030518
 - SEE E0900342 FOR OPTIC ORIENTATIONS.

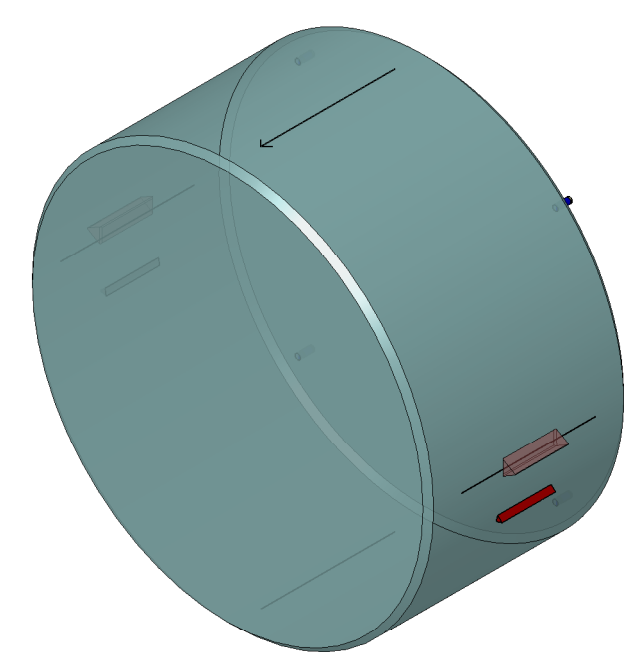

ISOMETRIC VIEW
SCALE 1:2

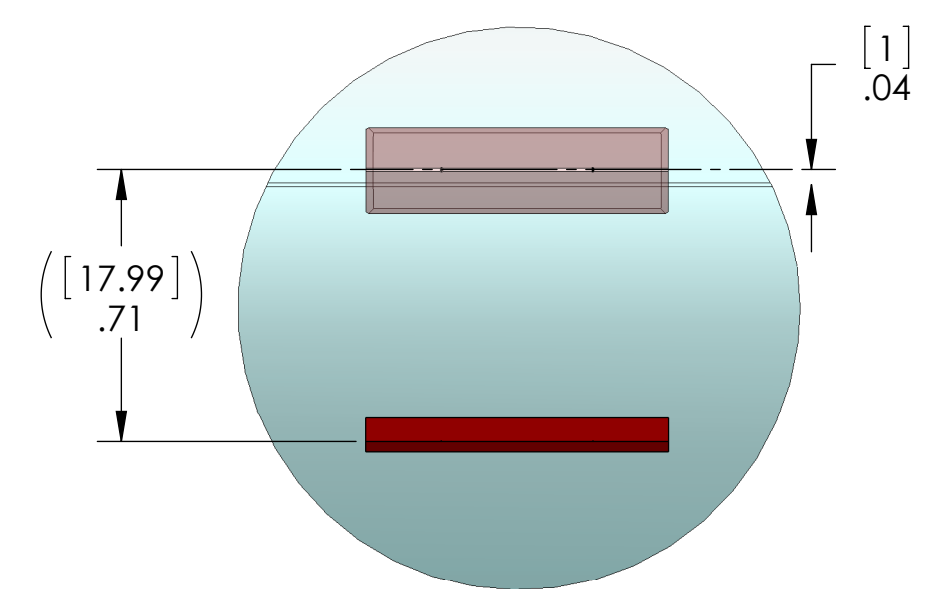
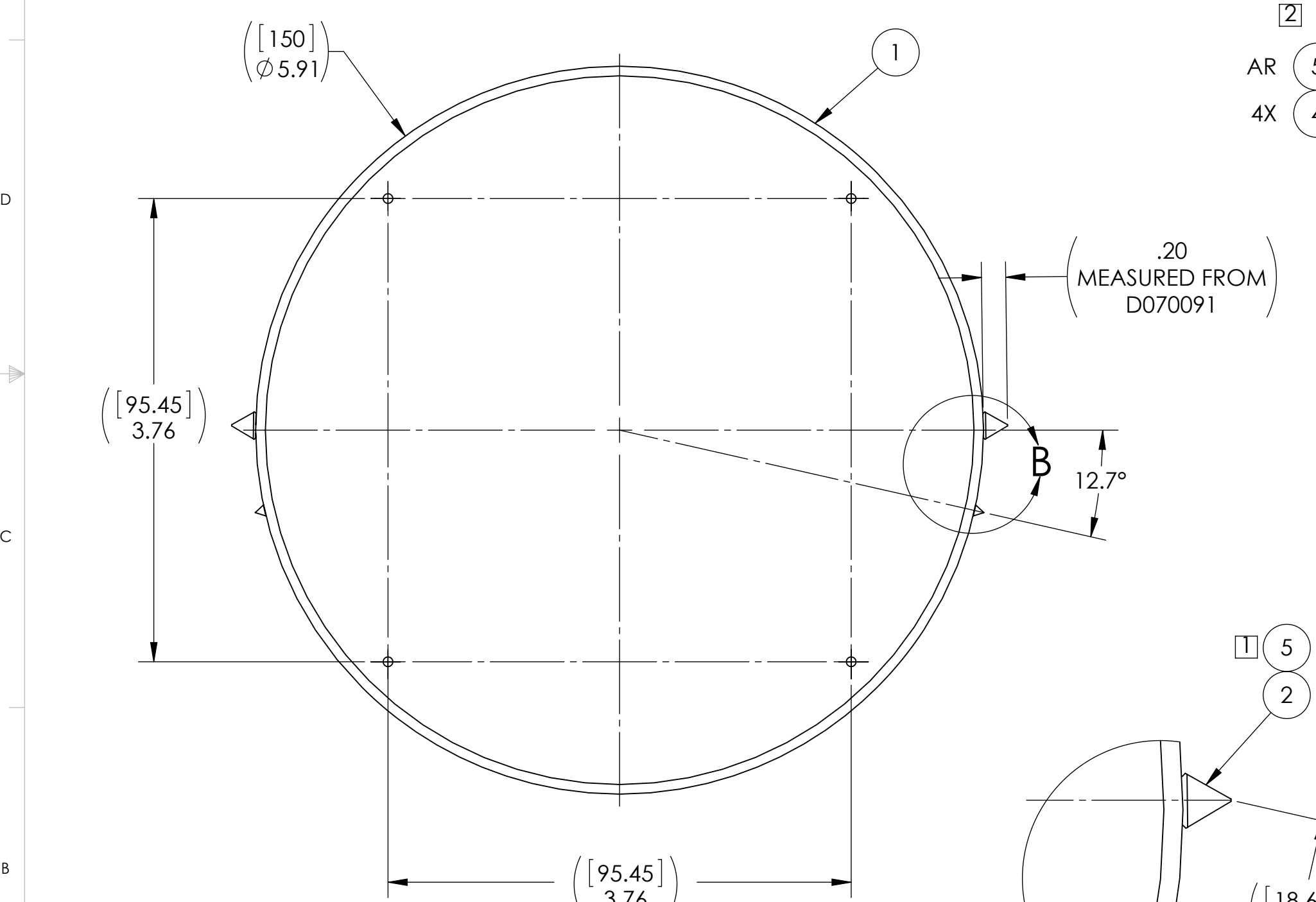

DETAIL A
SCALE 2:1

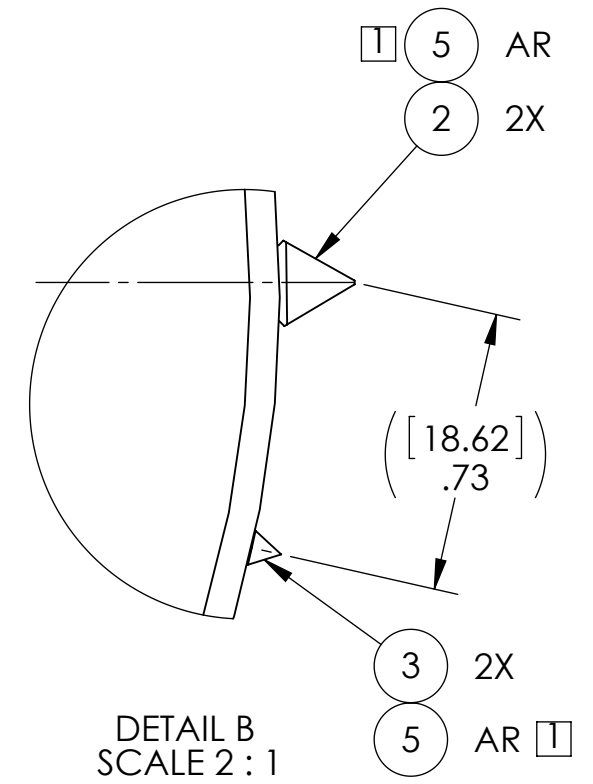

DETAIL B
SCALE 2:1

ITEM NO.	PART NUMBER	DESCRIPTION	MATERIAL	QTY.
5	EP30-2 MASTERBOND OR EQ.	UHV - COMPATIBLE ADHESIVE	N/A	A/R
4	D0902432	MAGNET/STANDOFF ASSEMBLY, HSTS TEST MASS	N/A	4
3	D0901278	HSTS SECONDARY METAL PRISM	304, 316 OR 302 SSTL	2
2	D0810033	PRISM BREAKOFF	SAPPHIRE	2
1	D070091	gLIGO INPUT MODE CLEANER FLAT MIRROR SUBSTRATE	FUSED SILICA	1

PARTS LIST

NOTES AND TOLERANCES: (UNLESS OTHERWISE SPECIFIED)				CALIFORNIA INSTITUTE OF TECHNOLOGY MASSACHUSETTS INSTITUTE OF TECHNOLOGY		PART NAME L1-MC3 Optic Assembly							
MATERIAL N/A		FINISH N/A μinch		SYSTEM ADVANCED LIGO		SUB-SYSTEM SUS		DESIGNER B. MOORE 20 DEC 2011		SIZE c	DWG. NO. D1101367		REV. v2
				NEXT ASSY D0900414		CHECKER SEE DCC SEE DCC		APPROVAL SEE DCC SEE CC		SCALE: 1:1	PROJECTION:	SHEET 1 OF 1	