

**NOTES CONTINUED:**

5. SCRIBE, ENGRAVE (A VIBRATORY TOOL MAY BE USED), LASER MARK OR MECHANICALLY STAMP (NO INKS OR DYES) DRAWING PART NUMBER, REVISION (AND VARIANT OR "TYPE" IF APPLICABLE) ON NOTED SURFACE OF PART FOLLOWED ON THE NEXT LINE WITH A THREE DIGIT SERIAL NUMBER. SERIAL NUMBERS START AT 001 FOR THE FIRST ARTICLE AND PROCEED CONSECUTIVELY. USE MINIMUM 0.12" HIGH CHARACTERS, UNLESS THE SIZE OF THE PART DICTATES SMALLER CHARACTERS. EXAMPLE: DXXXXXX-VY, TYPE-XX, S/N XXX

6. APPROXIMATE WEIGHT = 2.314 LB.

7. MACHINE ALL SURFACES TO REMOVE OXIDES AND MILL FINISH. USE OF ABRASIVE REMOVAL TECHNIQUES IS NOT ALLOWED. REFER TO LIGO-E0900364

8. ALL PARTS SHALL BE MANUFACTURED IN ACCORDANCE WITH LIGO SPECIFICATION E0900364.

9. ALL HELI-COIL HOLES TO BE PREPARED ACCORDING TO EMHART HELI-COIL PRODUCT CATALOG, HC2000, REV 4

10. ALL HELI-COIL INSERTS TO BE INSTALLED BY LIGO PERSONNEL. AFTER DELIVERY OF FINISHED PARTS, USE NITRONIC 60 THREADED INSERTS.

11. ALL MATERIAL IS TO BE VIRGIN MATERIAL (i.e. NO WELD REPAIRS, PLUGS OR RECYCLED MATERIAL). NO REPAIRS SHALL BE MADE UNLESS APPROVED IN ADVANCE, AND IN WRITING, BY LIGO LABORATORY. REFER TO LIGO-E0900364.

REV.	DATE	DCN #	DRAWING TREE #
v1	05-MAR-12	E1101043-v1	E1101044-v1
v2	12-SEPT-2012	E1200830-v1	E1101044-v2
v3	17-JUL-2013	E1300620-x0	E1200917-v4

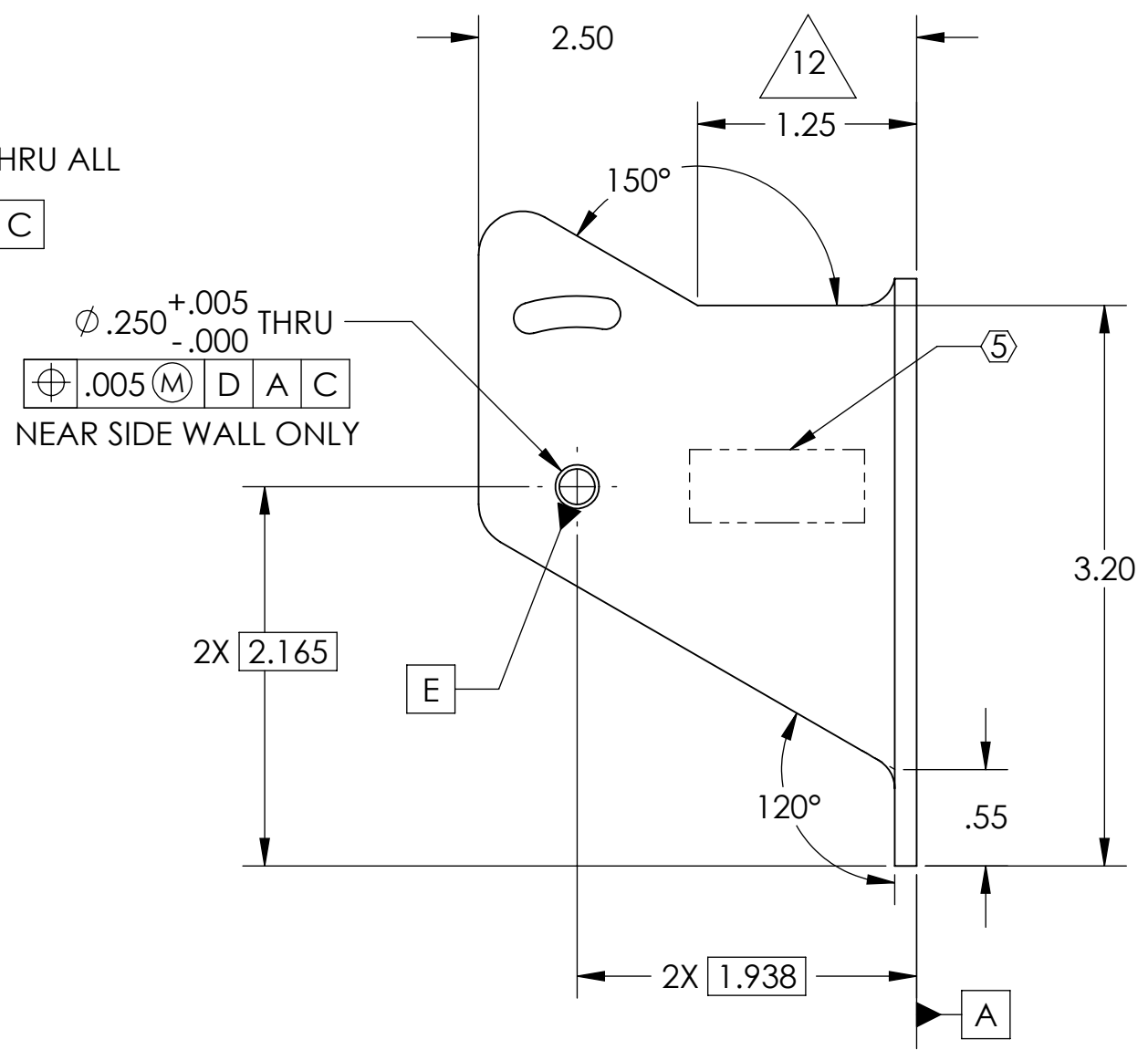
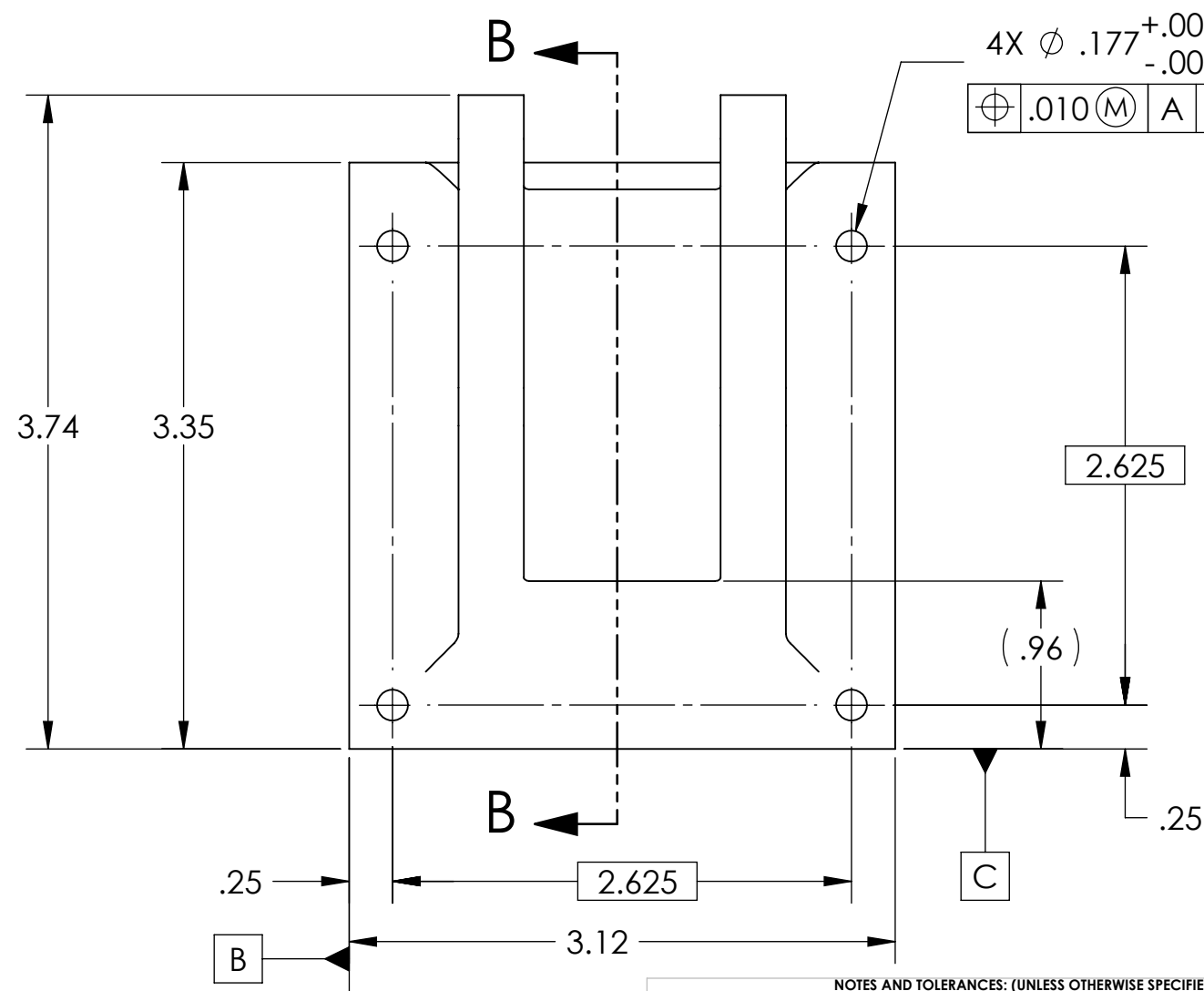
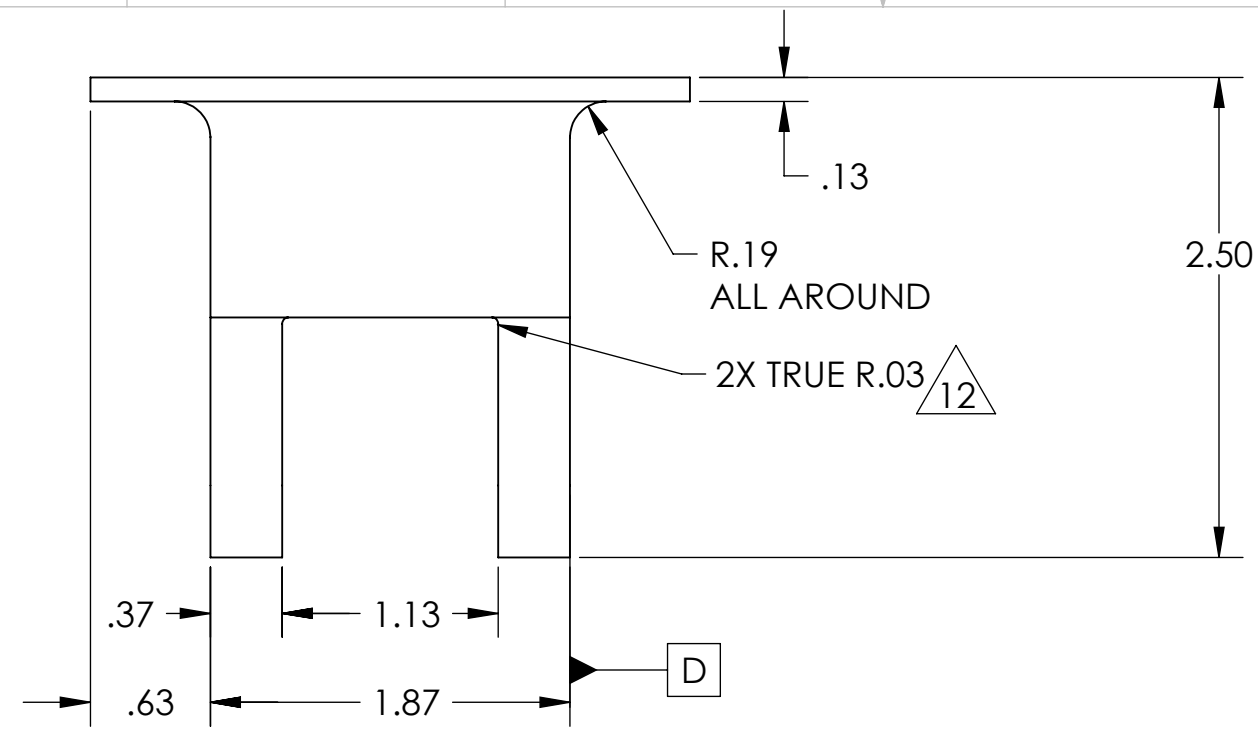
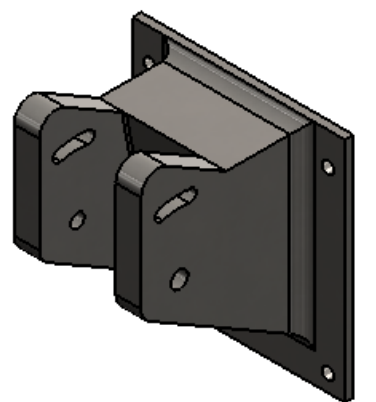

4X  $\phi .177^{+.005}_{-.000}$  THRU ALL  
 $\oplus .010 (M) A B C$

$\phi .250^{+.005}_{-.000}$  THRU  
 $\oplus .005 (M) D A C$   
 NEAR SIDE WALL ONLY

D1101292\_H1-L1 SM1 AZ SUPPORT BRKT, PART PDM REV: X-033, DRAWING PDM REV: X-018

**NOTES AND TOLERANCES: (UNLESS OTHERWISE SPECIFIED)**

DIMENSIONS ARE IN INCHES

TOLERANCES:  
 .XX ± .10  
 .XXX ± .005  
 ANGULAR ± 1.0°

MATERIAL	FINISH
AISI 304	63 μinch

CALIFORNIA INSTITUTE OF TECHNOLOGY MASSACHUSETTS INSTITUTE OF TECHNOLOGY		PART NAME	
SYSTEM ADVANCED LIGO		SUB-SYSTEM AOS	
NEXT ASSY		PART NAME	
D1102078		H1-L1 SM1 AZ SUPPORT BRKT	
DESIGNER	M. JACOBSON	07 JUL 2011	SIZE DWG. NO.
DRAFTER	A. COLE	12-OCT-11	B
CHECKER	C. GUIDO	01-JUL-13	
APPROVAL	M. JACOBSON	25-JUL-13	
		REV.	
		v3	
		SCALE: 1:2	
		PROJECTION:	
		SHEET 1 OF 2	

D1101292\_H1-L1\_SMI\_AZ\_SUPPORT\_BRKT, PART PDM REV: X-033, DRAWING PDM REV: X-018

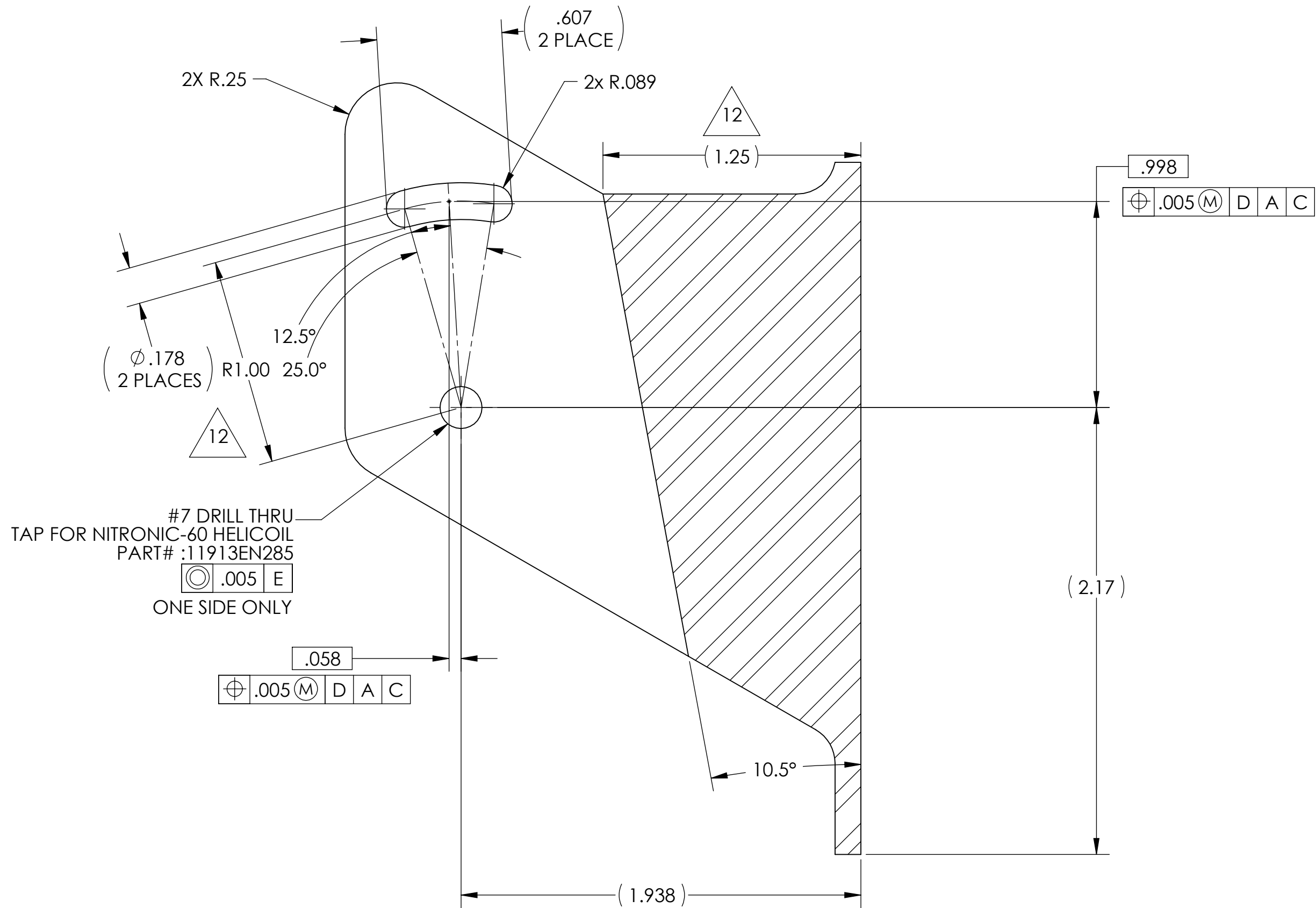

SECTION B-B  
SCALE 2 : 1

**LIGO** CALIFORNIA INSTITUTE OF TECHNOLOGY  
MASSACHUSETTS INSTITUTE OF TECHNOLOGY

SIZE	DWG. NO.	REV.
B	D1101292	v3
SCALE: 1:2	PROJECTION:	SHEET 2 OF 2