

- NOTES CONTINUED:**
5. SCRIBE, ENGRAVE (A VIBRATORY TOOL MAY BE USED), LASER MARK OR MECHANICALLY STAMP (NO INKS OR DYES) DRAWING PART NUMBER, REVISION (AND VARIANT OR "TYPE" IF APPLICABLE) ON NOTED SURFACE OF PART FOLLOWED ON THE NEXT LINE WITH A THREE DIGIT SERIAL NUMBER. SERIAL NUMBERS START AT 001 FOR THE FIRST ARTICLE AND PROCEED CONSECUTIVELY. USE MINIMUM 0.12" HIGH CHARACTERS, UNLESS THE SIZE OF THE PART DICTATES SMALLER CHARACTERS. EXAMPLE: DXXXXXX-VY, TYPE-XX, S/N XXX
  6. APPROXIMATE WEIGHT = X.XXX LB.
  7. MACHINE ALL SURFACES TO REMOVE OXIDES AND MILL FINISH. USE OF ABRASIVE REMOVAL TECHNIQUES IS NOT ALLOWED. REFER TO LIGO-E0900364
  8. ALL PARTS SHALL BE MANUFACTURED IN ACCORDANCE WITH LIGO SPECIFICATION E0900364.
  9. ALL HELICOIL HOLES TO BE PREPARED ACCORDING TO EMHART HELICOIL PRODUCT CATALOG, HC2009, REV.4
  10. ALL HELICOIL INSERTS TO BE INSTALLED BY LIGO PERSONNEL. AFTER DELIVERY OF FINISHED PARTS, USE NITRONIC 60-THREAD INSERTS.
  11. ALL MATERIAL IS TO BE VIRGIN MATERIAL (i.e. NO WELD REPAIRS, PLUGS OR RECYCLED MATERIAL). NO REPAIRS SHALL BE MADE UNLESS APPROVED IN ADVANCE, AND IN WRITING, BY LIGO LABORATORY. REFER TO LIGO-E0900364.
  12. SURFACE FINISH TO BE AS-PROCESSED FROM MILL/SUPPLIER, FREE FROM SCRATCHES OR GOUGES.
  13. PART WILL BE PORCELAIN COATED PER LIGO SPECIFICATION E1090083 AFTER FABRICATION. THE INDICATED HOLES WILL BE MASKED PRIOR TO PORCELAIN COATING TO APPROXIMATELY 2.5-3X HOLE DIAMETER CENTERED ON BOTH SIDES OF THE HOLE.
  14. DIMENSIONS APPLY BEFORE PORCELAIN COATING UNLESS SPECIFIED.
  15. BEND RADIUS: UNLESS OTHERWISE NOTED, THE BEND RADIUS SHOULD BE THE MINIMUM REQUIRED TO FORM WITHOUT CRACKING OR REQUIRING ADDITIONAL WORK WHEN FORMING. IN PARTICULAR IF SHEET METAL IS TO BE PORCELAIN COATED, THE BEND RADIUS SHALL BE A MINIMUM OF .12" OUTSIDE RADIUS OF BEND UNLESS OTHERWISE NOTED.

NOTES 9, 10, 13, 14 and 15 DO NOT APPLY TO THIS PART

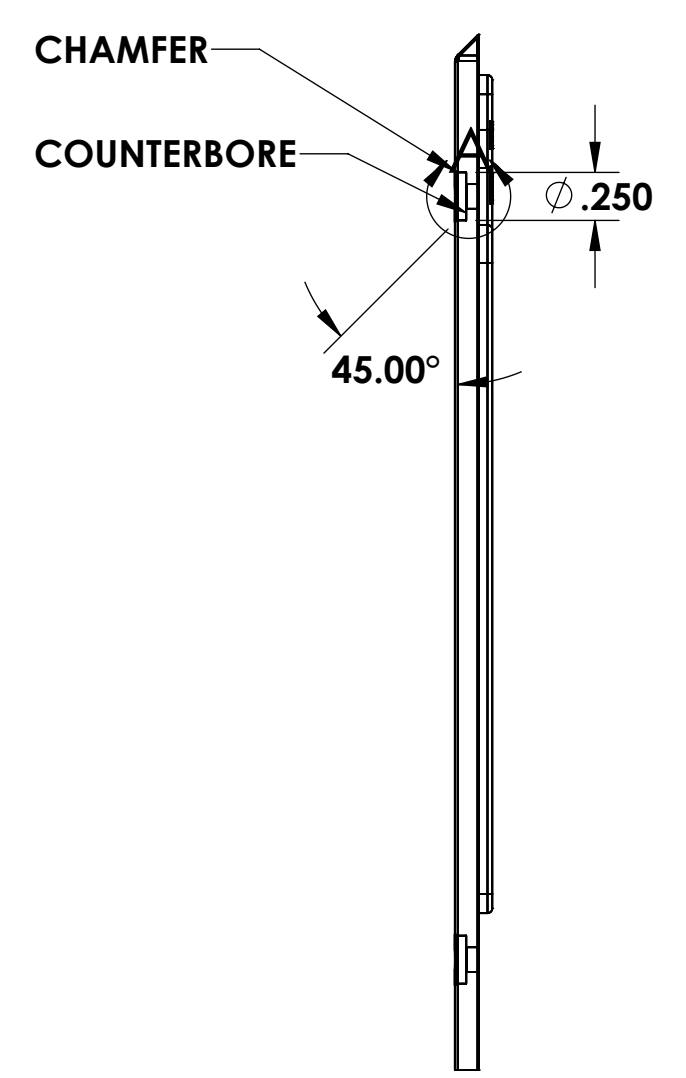

MACHINED "V" CHANNEL ENGRAVED INSCRIPTION

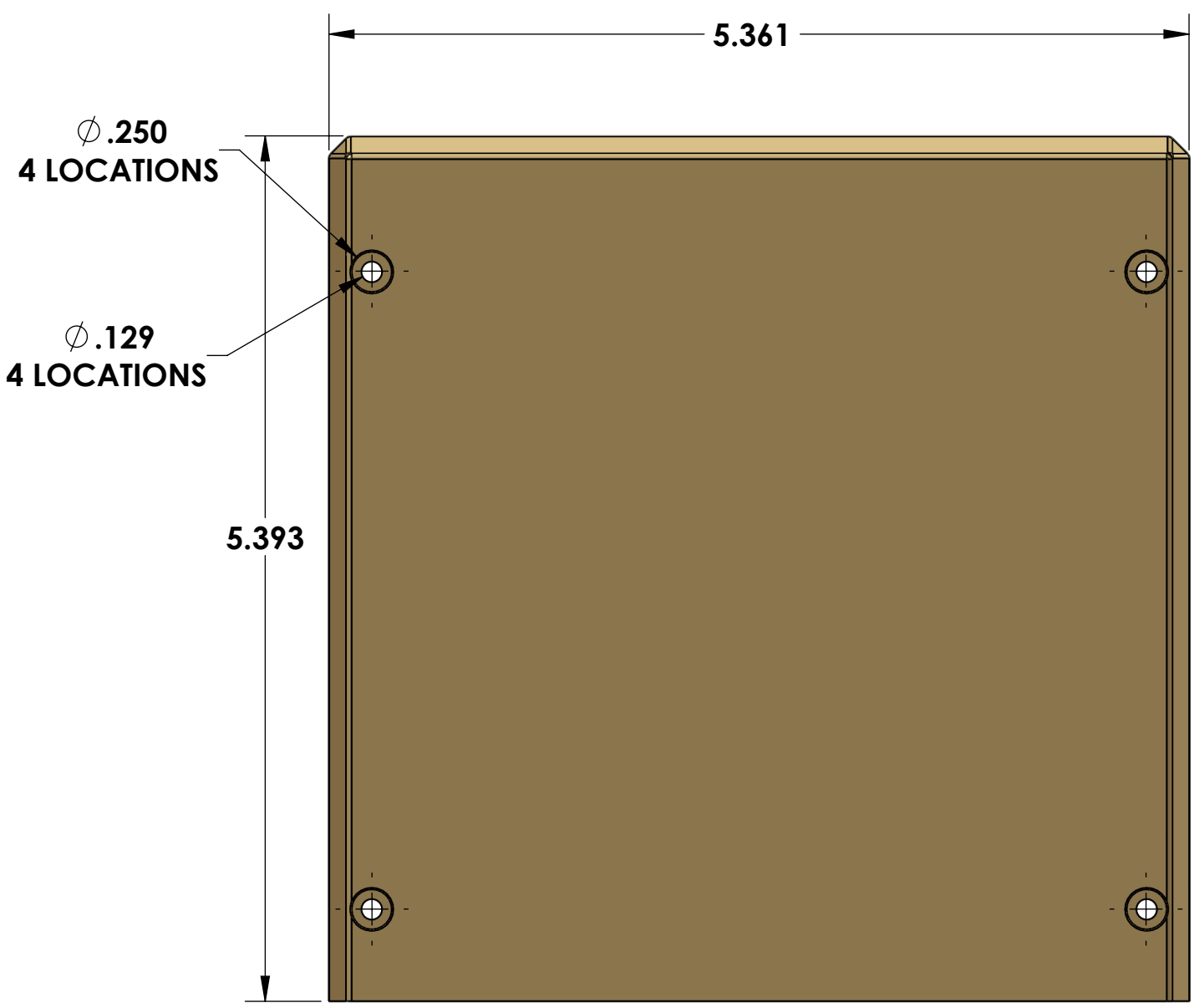
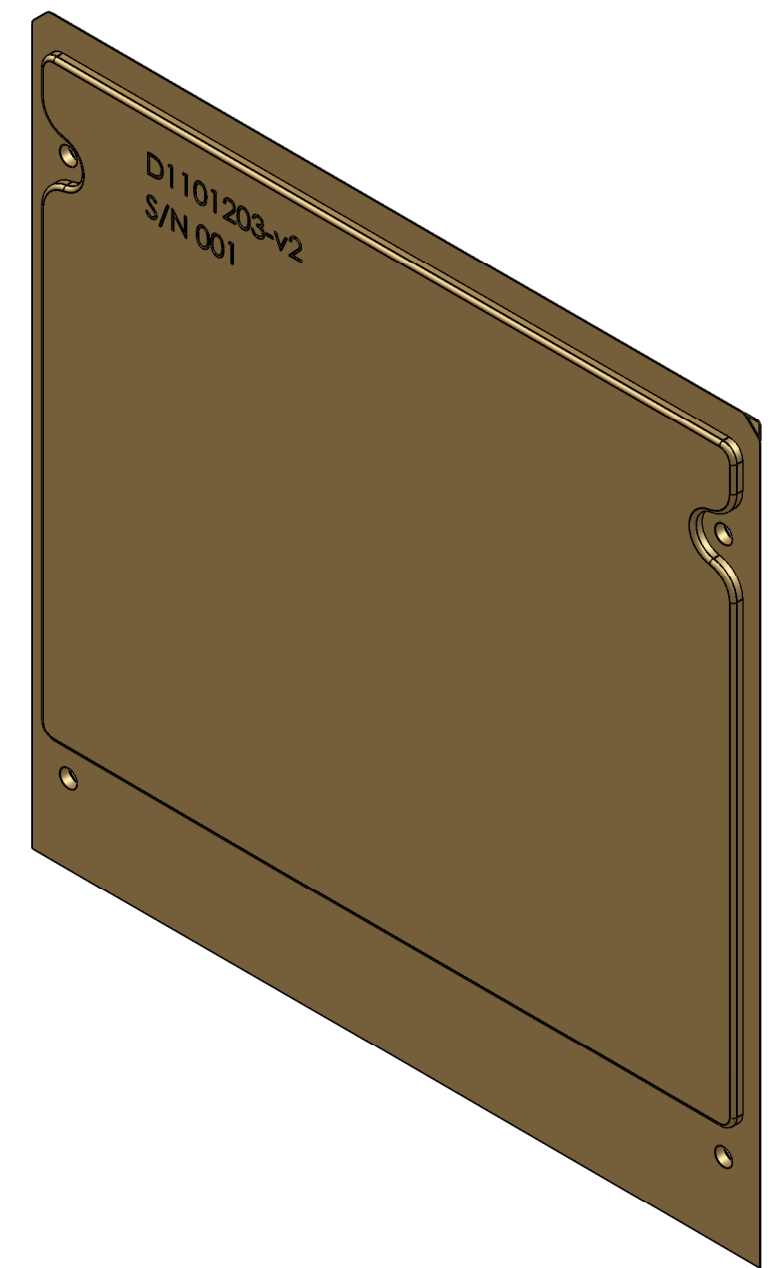
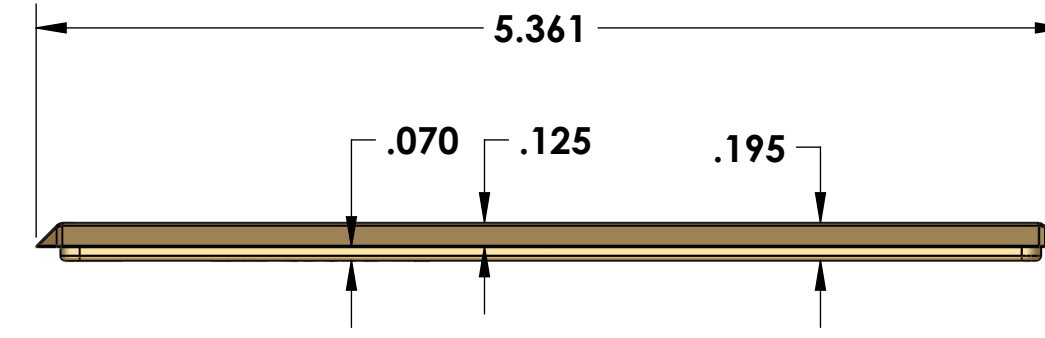
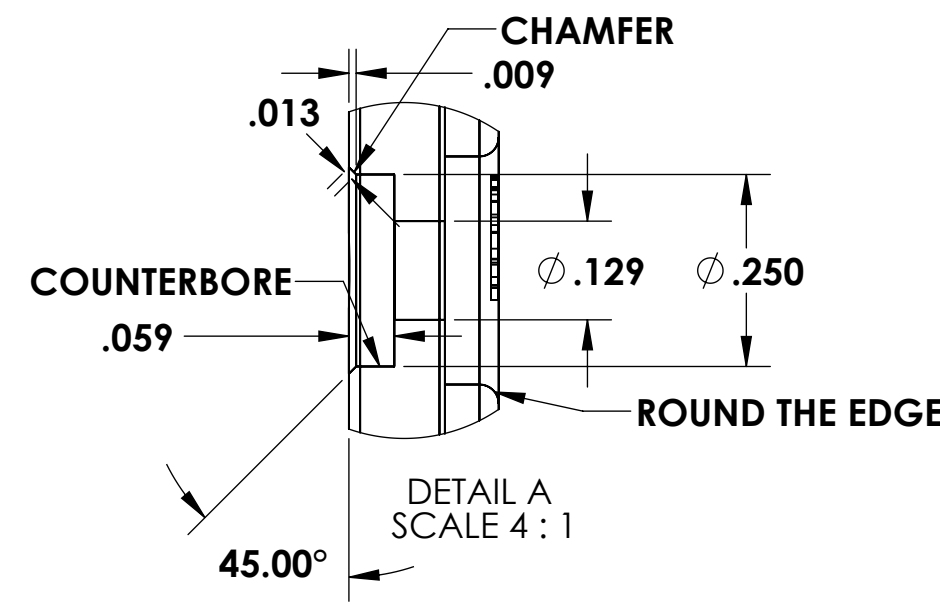
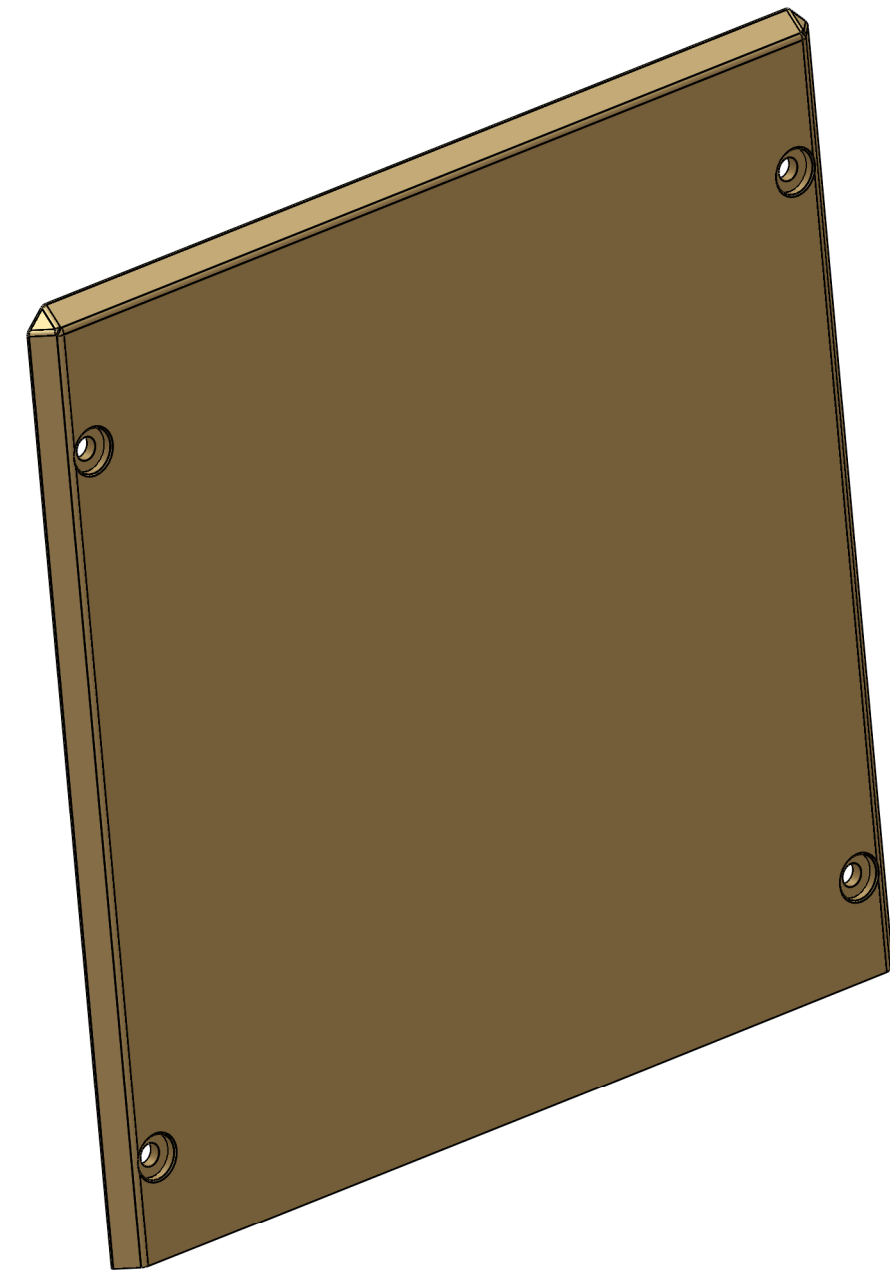
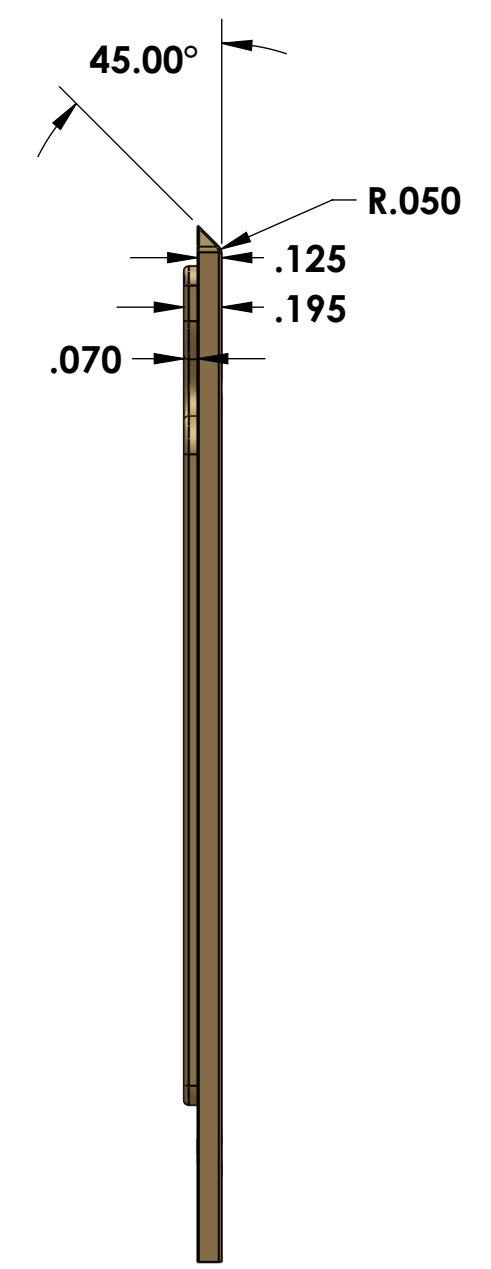
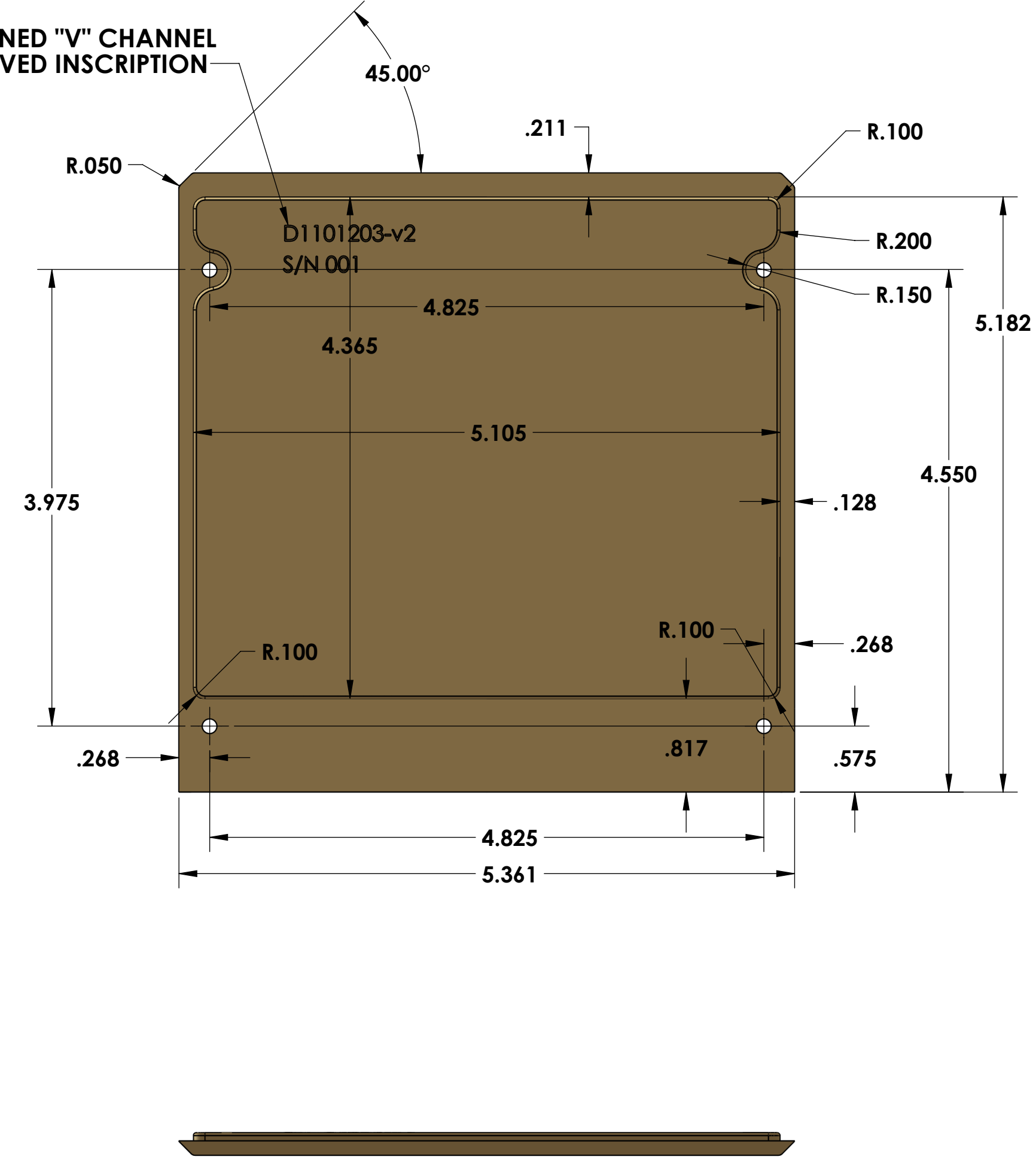

REV.	DATE	DCN #	DRAWING TREE #
-	-	-	-
-	-	-	-
-	-	-	-

NOTES AND TOLERANCES: (UNLESS OTHERWISE SPECIFIED)	
1. INTERPRET DRAWING PER ASME Y14.5-1994.	
2. REMOVE ALL SHARP EDGES, .005-.015, FOR MACHINED PARTS. ROUND ALL EDGES APPROXIMATELY R.02 FOR SHEET METAL PARTS.	
3. DO NOT SCALE FROM DRAWING.	
4. ALL MACHINING FLUIDS MUST BE FULLY SYNTHETIC, FULLY WATER SOLUBLE AND FREE OF SULFUR, SILICONE, AND CHLORINE.	
MATERIAL	Material <not specified>
FINISH	μinch

<b>LIGO</b> CALIFORNIA INSTITUTE OF TECHNOLOGY MASSACHUSETTS INSTITUTE OF TECHNOLOGY	SYSTEM	SUB-SYSTEM	ISC
NEXT ASSY			

PART NAME				<b>ASC_IN-AIR ENCLOSURE - LID - v2</b>			
DESIGNER	R. ABBOTT	JAN/25/2012	SIZE	DWG. NO.	REV.		
DRAFTER	E. BROWN	JAN/25/2012	D	<b>D1101203</b>	<b>v2</b>		
CHECKER							
APPROVAL			SCALE: 1:1	PROJECTION:	SHEET 1 OF 1		

D1101203\_ASC\_AIR-v2\_Exploding - LID\_PART\_PDM\_REV-X-000\_DRAWING\_PDM\_REV-X-001