

# Charge mitigation and measurement of the GEO600 test-masses

M Hewitson, J. Degallaix, H. Grote, S. Hild, J. Hough, H Lück, S. Rowan, K. A. Strain, J. R. Smith, B. Willke  
 AEI Hannover (MPI für Gravitationsphysik und Leibniz Universität Hannover)  
 Department of Physics and Astronomy, University of Glasgow

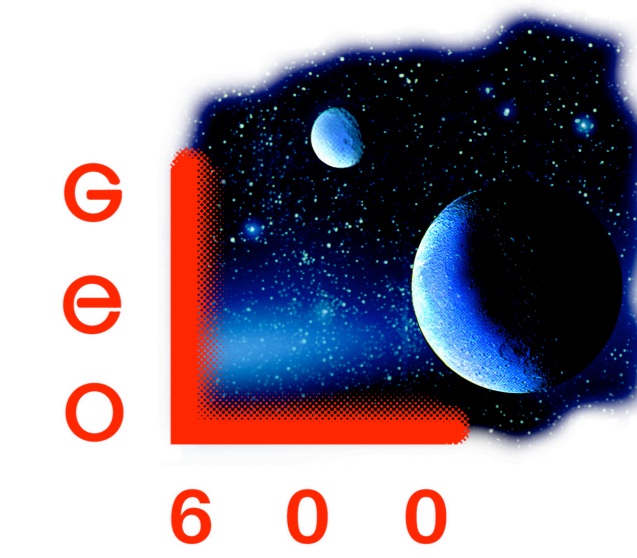

G070416-00-1

## Introduction

GEO600 is a Gravitational Wave Observatory based on a Michelson Interferometer with 600m long arms. One novel feature of GEO is that the main test-masses are suspended as triple pendulums, with a monolithic, fused-silica bottom stage. As a result, the test-masses are extremely well electrically isolated.

During December of 2006, GEO 600 experienced an extended power-cut which resulted in various damaged subsystems. After repairs, it was clear that the electro-static actuators used by GEO to control the longitudinal position of the main test-masses had less actuation strength than before. After ruling out the known causes for such a problem, the remaining suspicion was charges on the test-mass.

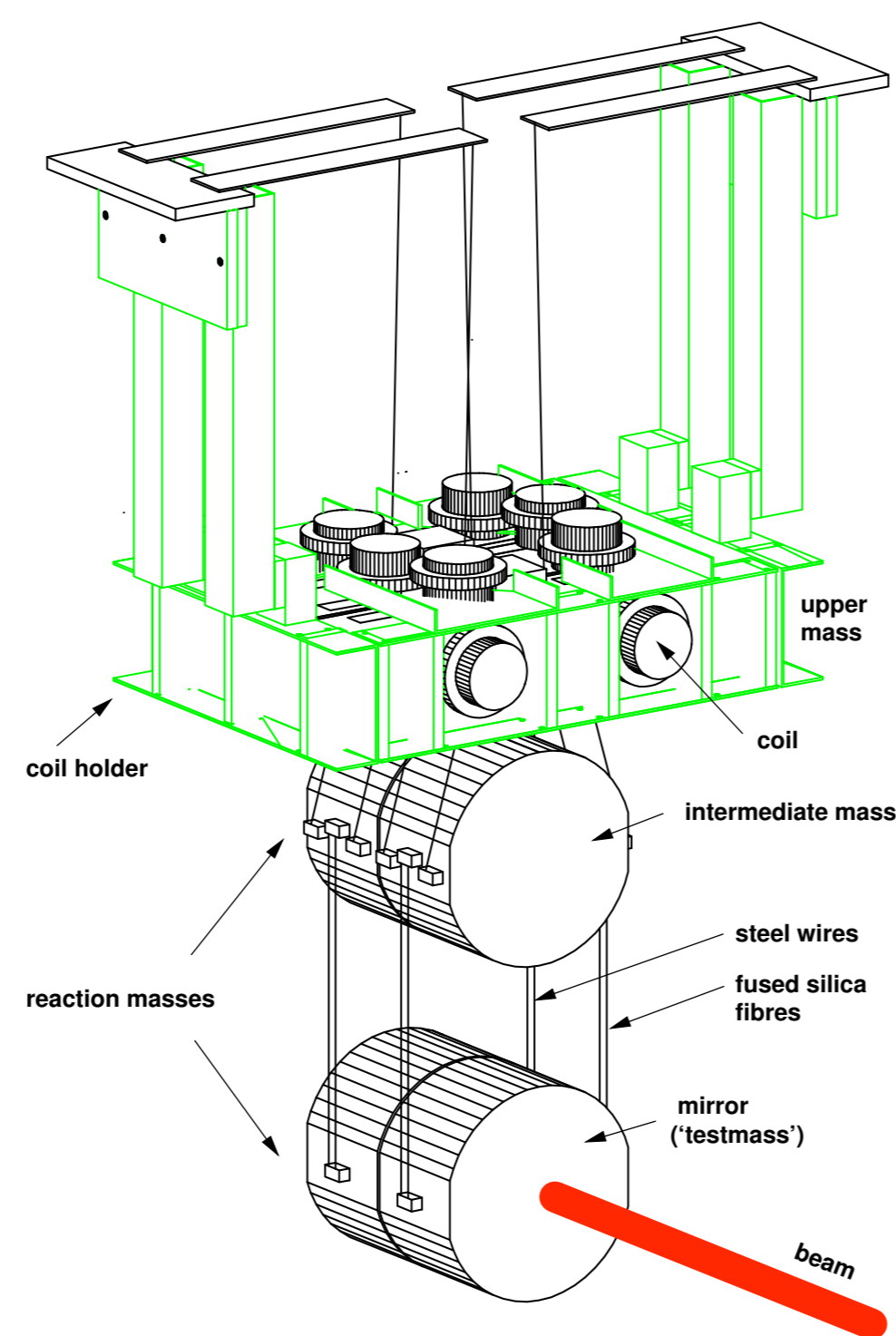

**Figure 1:** Schematic of the GEO main test-mass suspension system.

## Effect of charged test-mass on ESDs

The electro-static drives (ESD) comprise a gold pattern deposited on the surface of the reaction-mass. Figure 2 shows the details of this electrode pattern.

In order to achieve a bi-polar action from the uni-polar dielectric action, one set of electrodes is held at a high bias voltage,  $V_{\text{bias}}$ , with the drive signal,  $V_s$ , superimposed; the other electrodes are held at 0 V. The force on the test-mass can then be written

$$F = A(V_{\text{bias}} + V_s)^2 \quad (1)$$

This can be converted to an effective displacement at a drive signal frequency,  $\omega$ , by

$$x_\omega = 2 \frac{A'}{\omega^2} V_{\text{bias}} V_\omega \quad (2)$$

If we now consider the effect of having a charged test-mass in the presence of stray electric fields created between the high-voltage electrodes and the surrounding metal-work, we can write an additional term that is proportional to the drive signal such that the resulting displacement is modified as

$$x_\omega = 2 \frac{A'}{\omega^2} V_{\text{bias}} V_\omega + \frac{\beta}{\omega^2} V_\omega \quad (3)$$

$$= \frac{2A'}{\omega^2} (V_{\text{bias}} + \beta') V_\omega \quad (4)$$

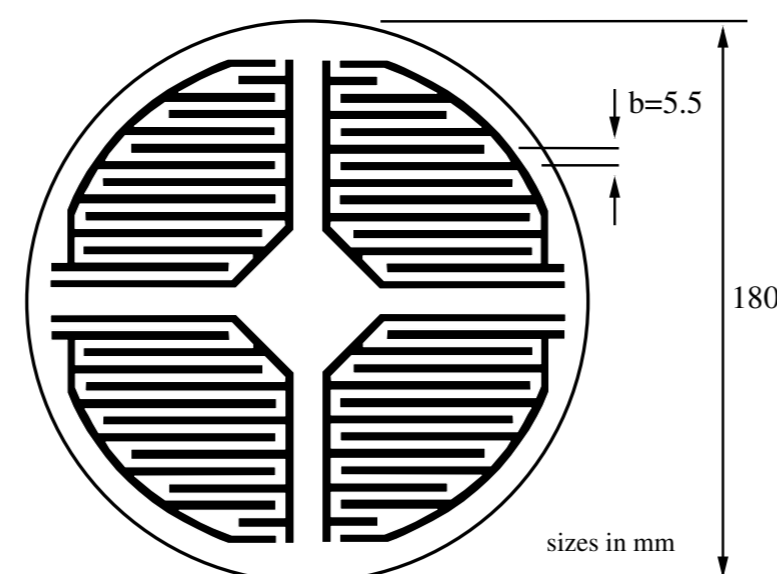

**Figure 2:** Electrode pattern of the GEO ESDs.

## Charge measurement

Equation 4 immediately suggests a way to measure the coefficient  $\beta'$  and hence have some measure of the effective charge present on the test-mass. If we consider a normalised (by the drive signal) displacement written as

$$\bar{x} = \frac{x_\omega}{V_\omega} = |aV_{\text{bias}} + b| \quad (5)$$

From this formulation, we can measure the normalised displacement as a function of applied bias. From such a measurement we can determine an effective bias due to the presence of charges on the test-mass. This is determined by

$$V_{\text{eff}} = -b/a \quad (6)$$

## After power-cut

This measurement method described above was used to determine the effective bias due to charges after the power-cut described earlier. The measurement was made at 696 Hz and the results are shown in Figure 3. The coefficients yield an effective bias of 333 V.

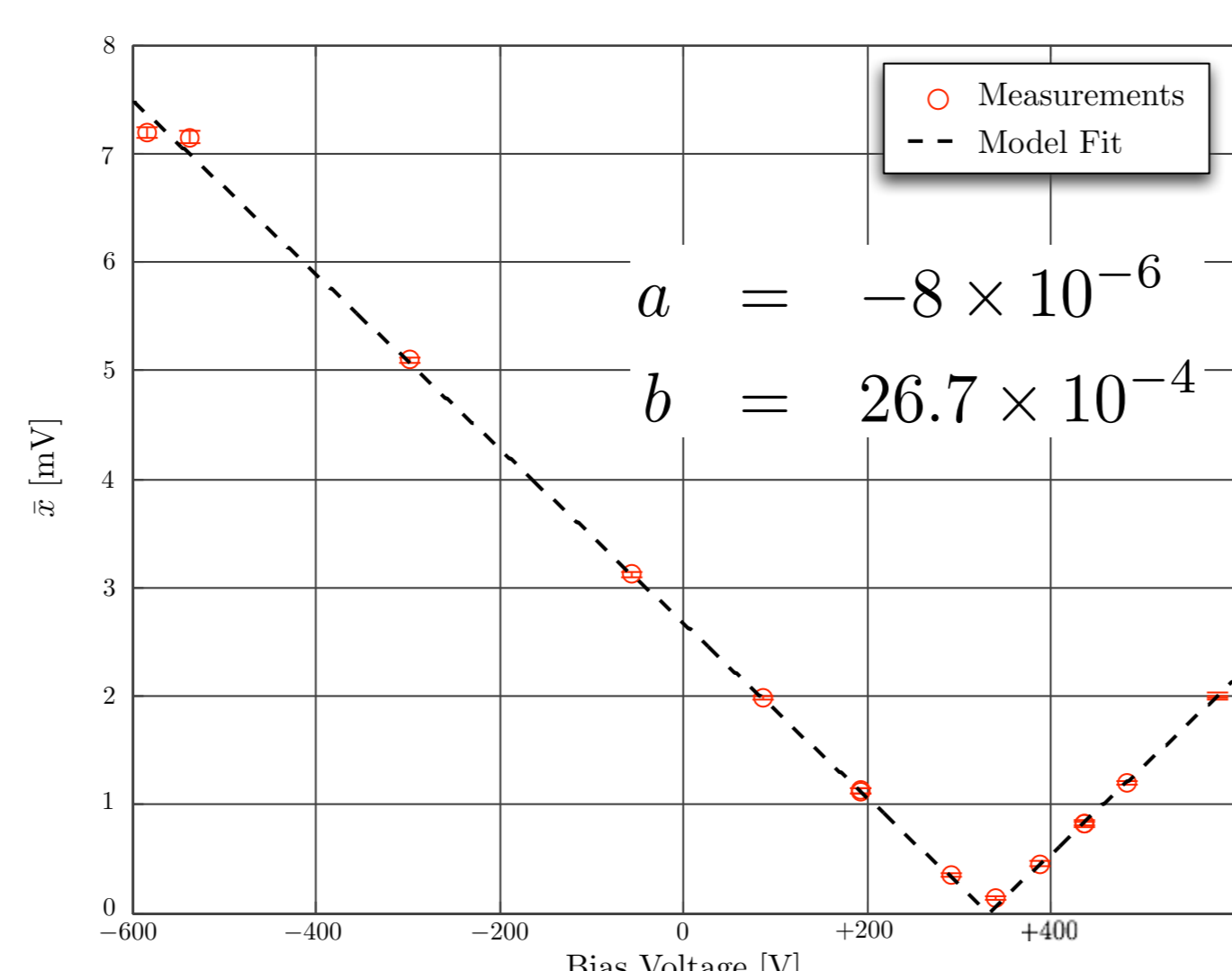

**Figure 3:** East test-mass charged after the power-cut. This measurement was made on 12th December 2006.

## UV Illumination

The open-loop gain of the Michelson longitudinal servo can be directly used to track changes in the charge-state of the test-masses (assuming roughly constant optical gain). Over the period from December 2006 to February 2007 the loop-gain remained fairly constant so we can say that the charge-state of the test-masses remained constant within a few percent.

In late February 2007, the vacuum system at GEO was opened to make various changes. After the vacuum was re-established, the charge state of the East test-mass was re-measured, this time at 1234 Hz. This time the effective bias was measured to be 148 V (see Figure 5).

During the vacuum work the viewports were replaced with fused-silica ones - transparent to UV light - allowing for the possibility of using UV light to discharge the test-masses. (Previously Kodial viewports were installed which are effectively opaque for UV, which means early attempts at UV discharging failed.)

Next we tried UV illumination of the East test-mass again and this time we tracked the strength of an injected line (injected into the East ESD) in the main detector output signal. The illumination was applied with the East ESD bias turned off and the detector locked using only the North ESD. The measured line height is shown in Figure 4 for the first 2 hours of illumination. The detector was then unlocked (for safety) and the illumination continued for a further 13 hours. The charge state of the East test-mass was then remeasured to be -66 V. The illumination process had negatively charged the test-mass.

An attempt was then made to recharge the test-mass. The ESD bias was switched on to +200 V. Short bursts of UV illumination (20s) were directed at the test-mass and the effective bias was measured after each step. The steps were repeated until the effective bias was close to 0 V. The final charge measurement is shown in Figure 6.

The various measurements and fits are summarised below:

Value of $a$	Value of $b$	$V_{\text{eff}}$ [V]	Measurement details
$-8 \times 10^{-6}$	$26.7 \times 10^{-4}$	333	Measurement made after power-cut: 12 December 2006.
$-1.2 \times 10^{-6}$	$1.82 \times 10^{-4}$	148	Measurement made after vacuum work: 7 March 2007.
$-1.2 \times 10^{-6}$	$-7.7 \times 10^{-5}$	-66	Measurement made after overnight UV illumination.
$-1.5 \times 10^{-6}$	$2.7 \times 10^{-5}$	17.6	Measurement made after re-charging process with applied bias and UV illumination.

Normalising the first measurement by the ratio of the square of the measurement frequency, and accounting for the change in optical gain between these frequencies yields a value of  $a = -1 \times 10^{-6}$  which shows that the value of  $a$  appears independent of the charge state, as expected.

## Summary

The presence of charge build-up on the GEO600 test-masses has consequences, not only for the noise performance of the detector, but also for control and calibration of the Michelson. We describe here a method to measure the charge-state of a test-mass using the electro-static actuators, and show successful discharging of the test-masses using UV light. It should be noted that this measurement method only measures the difference between the charge-state of the test-mass and the reaction mass.

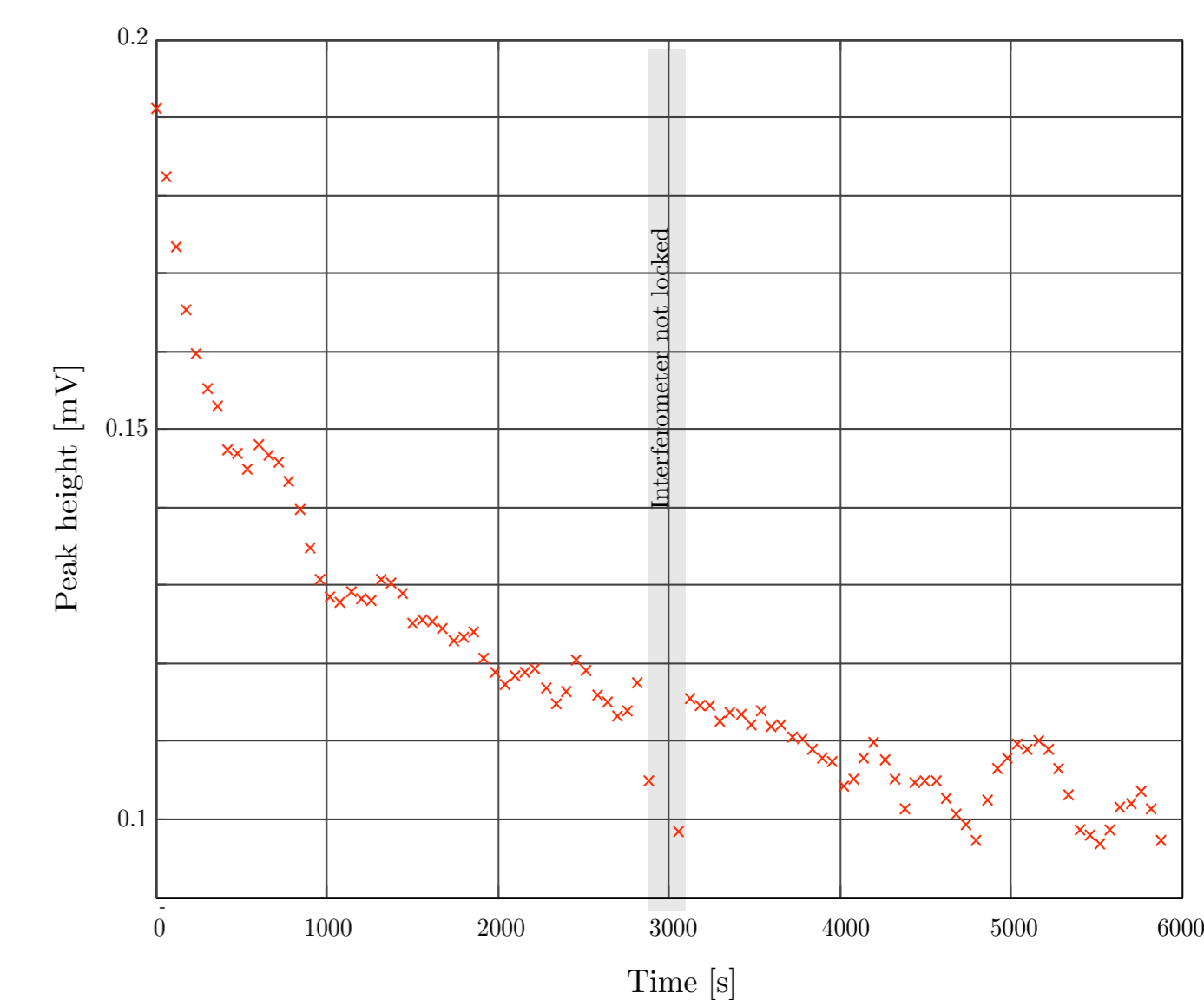

**Figure 4:** Tracking the strength of the east ESD during the UV illumination process via an injected spectral line. The line height is normalised by the optical cavity power.

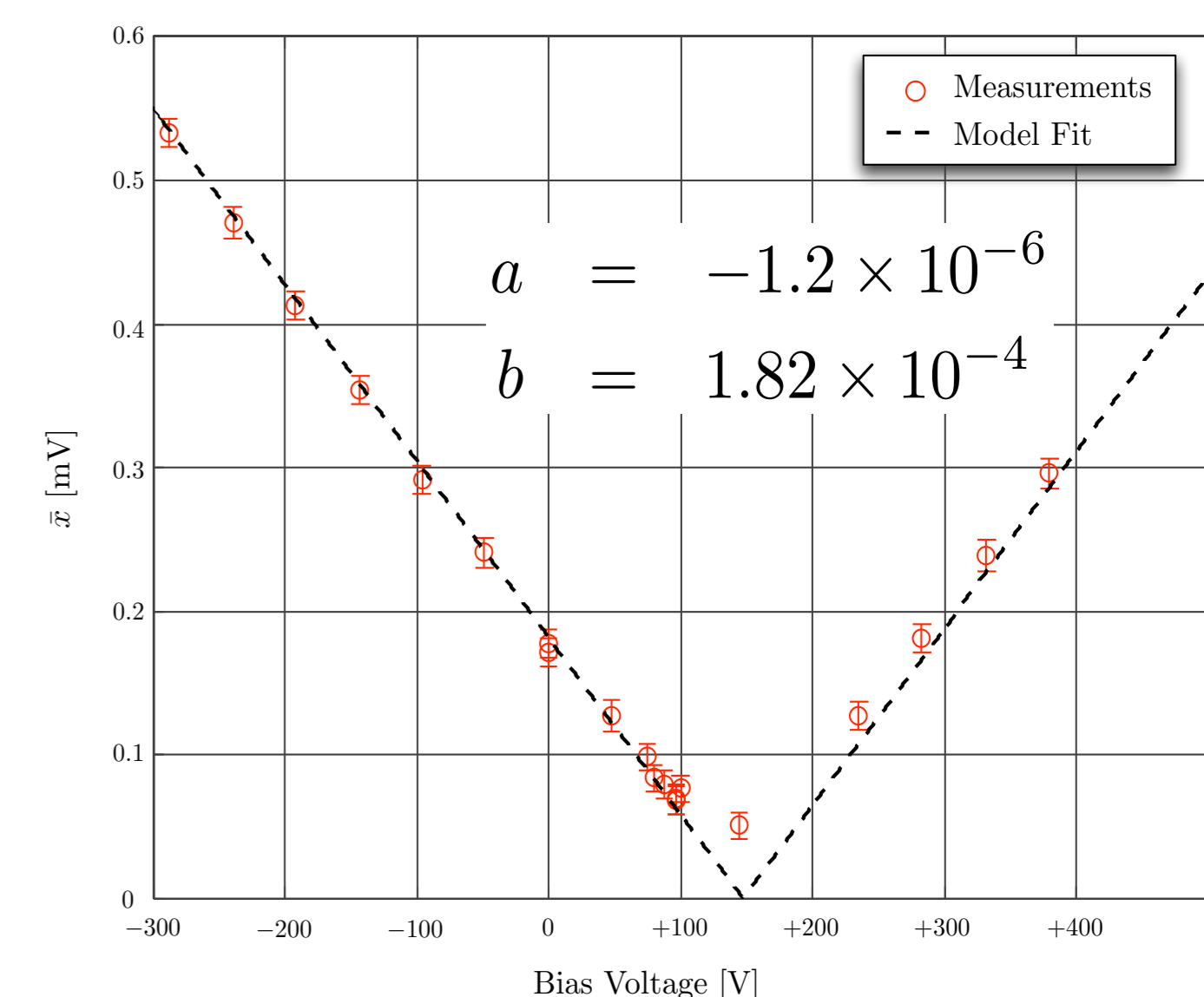

**Figure 5:** East test-mass charged after the Vacuum work. This measurement was made on 7th March 2007.

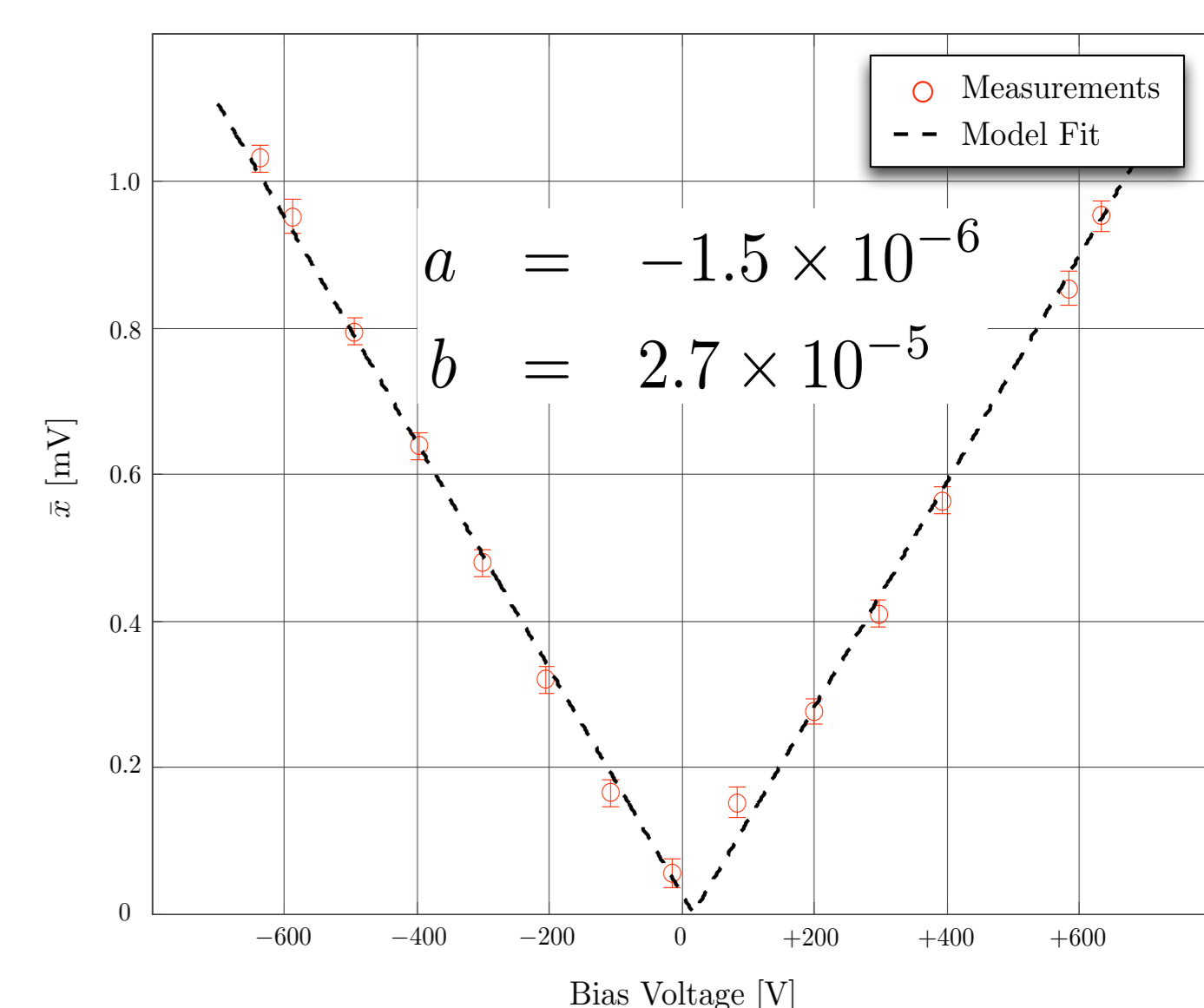

**Figure 6:** East test-mass charge-state after the recharging process. Recharging was achieved by UV illumination in the presence of the ESD bias.