Advanced LIGO Research and Development

David Shoemaker

PAC

2 December 2004

NSB considered Adv LIGO

- NSB meeting 13-14 October 2004
- “The Board concurred that planning for Advanced LIGO is sufficiently advanced and the intellectual value of the project sufficiently well demonstrated to justify consideration by the Acting Director and the National Science Board for funding in FY 2007 or a future NSF budget request.”
- Hurrah!

A few comments

- Earliest funding possible is FY 2007
 - » Good news: two new MREFC starts allowed in FY05
 - » Bad news: NSF at -2%, future funding prospects not rosy
- Sequence **if** FY 2007 funding:
 - » Build up of stock of subassemblies, 2007-2010
 - » First ifo decommissioned in mid-2010
 - » Second decommissioned in late 2010
 - » First ifo back up (integration/test completed) in early 2012
 - » End of MREFC Project, all ifos in commissioning, in mid 2013
- Approval was for ~\$185M (10% more ok without NSB review)
 - » Assumes contribution from UK (\$12M, approved), Germany (\$12M, TBD), Australia (\$2.3M, TBD)
- Scope is for three 4km instruments, and all labor
 - » Difficult-to-manage link between Project and Operations – Stan to discuss

Advanced LIGO Project – Preliminary Schedule (Carol Wilkinson)

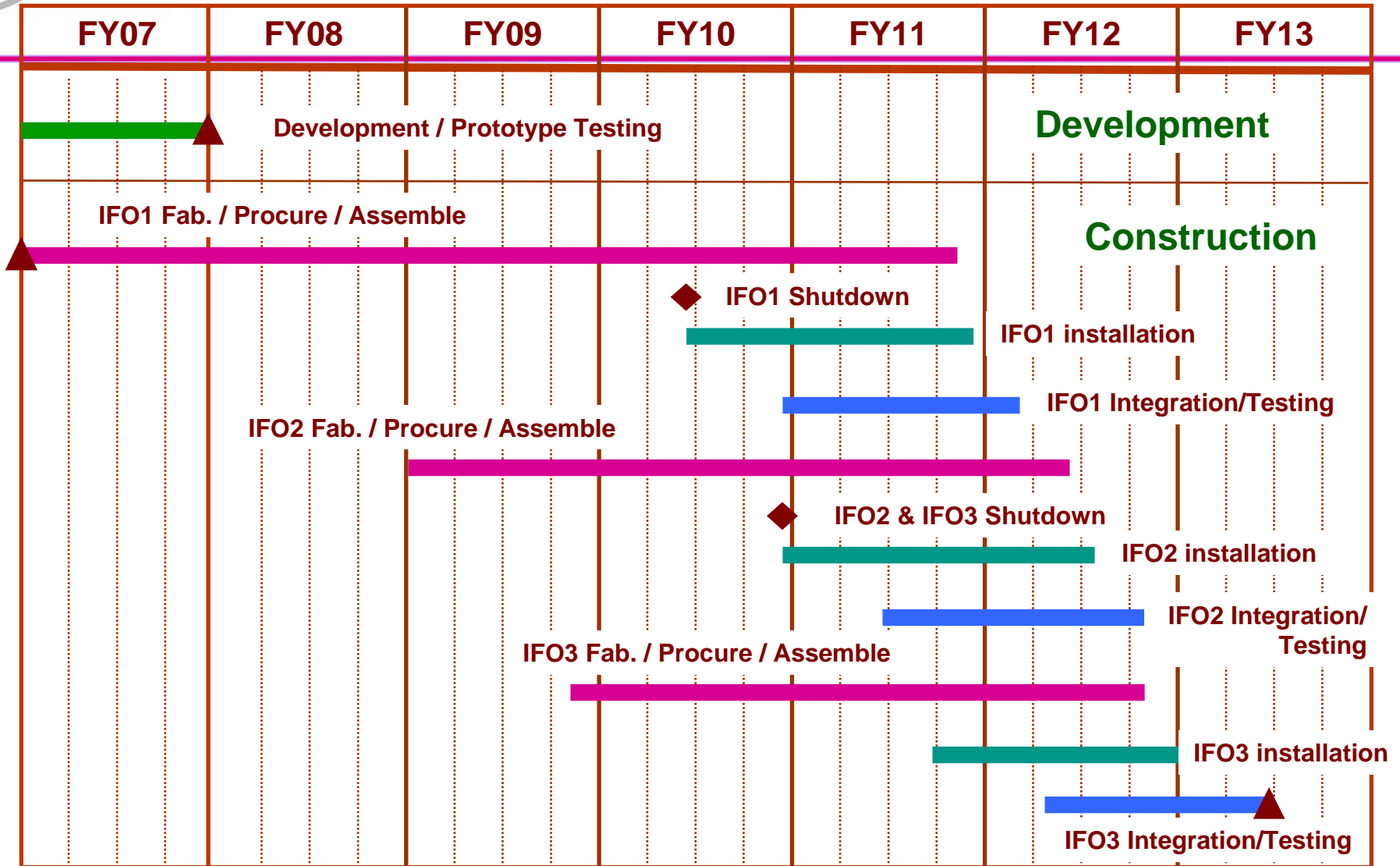

A few more comments

- ...the rest of the NSB public statement:
- “The Board approved the resolution with the understanding that the existing LIGO Program will collect at least a year’s data of coincident operation at the science goal sensitivity before initiating facility upgrades to the new Advanced LIGO technology.”
- Expect to start in mid-to-late 2005 with SRD-sensitivity runs
- Present best single ifo duty cycle ~65%, no basic hurdle to improvements; guess ~65% for three ifos reasonable
- Could integrate up to one year observation in ~1.5 years, or early 2007 – very important to be on track as the NSF moves forward in the Adv LIGO funding process
- Actually expect to do much more by 2010 – networked observation with Virgo/GEO/TAMA, incremental improvements to instrument – no concern about not adequately exploiting initial LIGO

And just for fun...

- Annual NSF Review, 8-9 November 2004
- “Approval of the construction of Advanced LIGO by the National Science Board is welcome news for the Panel. The Panel urges the LIGO collaboration and the National Science Foundation to move forward as aggressively as possible with the construction of this important project.”
- So, on to
 - » Technical highlights,
 - » organizational points

Initial and Advanced LIGO

- Factor **10** better amplitude sensitivity
 - » $(\text{Reach})^3 = \text{rate}$
- Factor **4** lower frequency bound
- NS Binaries: for three interferometers,
 - » Initial LIGO: ~ 20 Mpc
 - » Adv LIGO: ~ 350 Mpc
- BH Binaries:
 - » Initial LIGO: $10 M_{\odot}$, 100 Mpc
 - » Adv LIGO : $50 M_{\odot}$, $z=2$
- Stochastic background:
 - » Initial LIGO: $\sim 3e-6$
 - » Adv LIGO $\sim 3e-9$

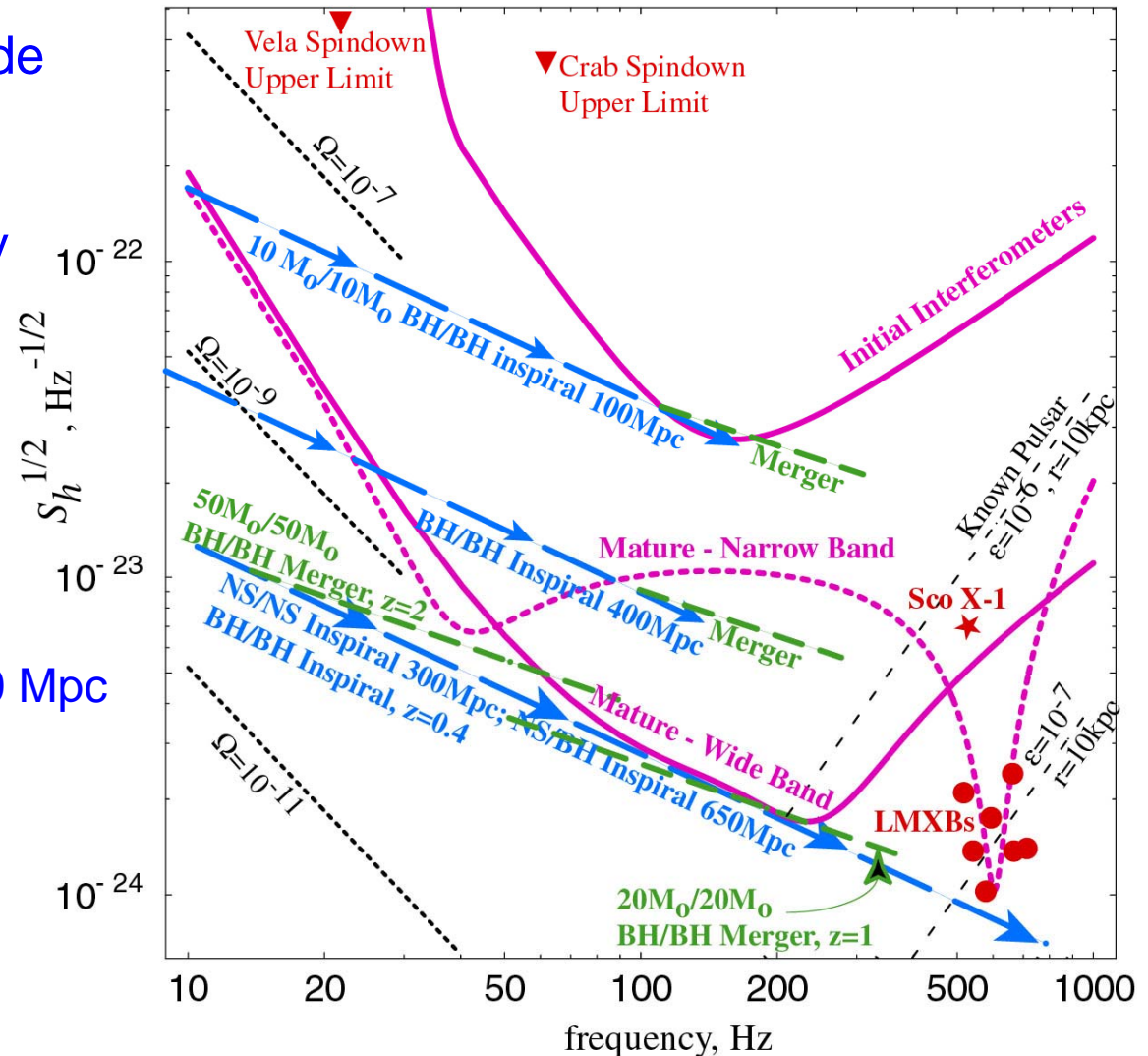

Anatomy of the projected Adv LIGO detector performance

- Newtonian background, estimate for LIGO sites
- Seismic 'cutoff' at 10 Hz
- Suspension thermal noise
- Test mass thermal noise
- Unified quantum noise dominates at most frequencies for full power, broadband tuning
- Possible upgrades: variable signal recycling mirror, flat-top beams, squeezing, Newtonian background regression, test-mass substitution, 4th interferometer...

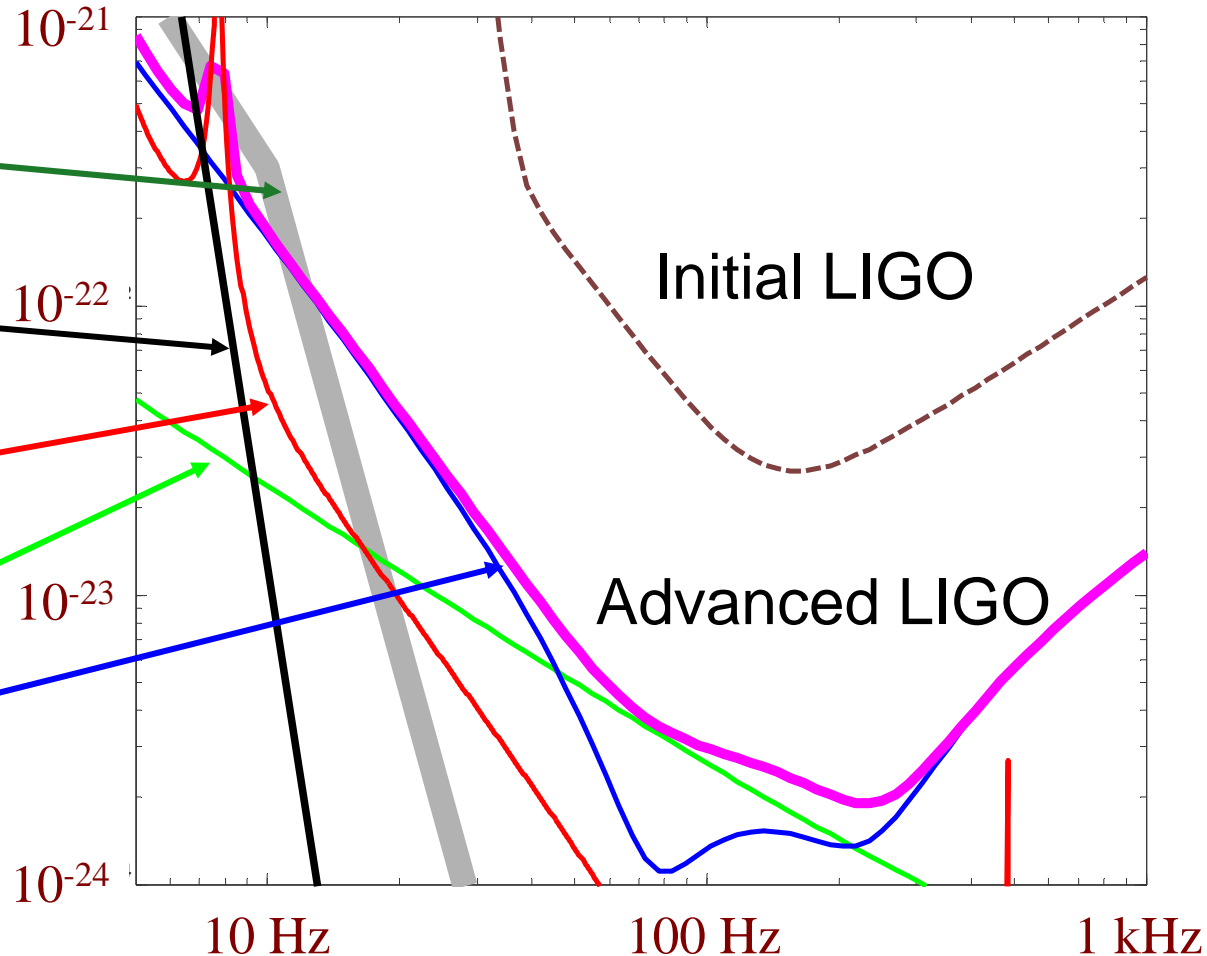

Design features

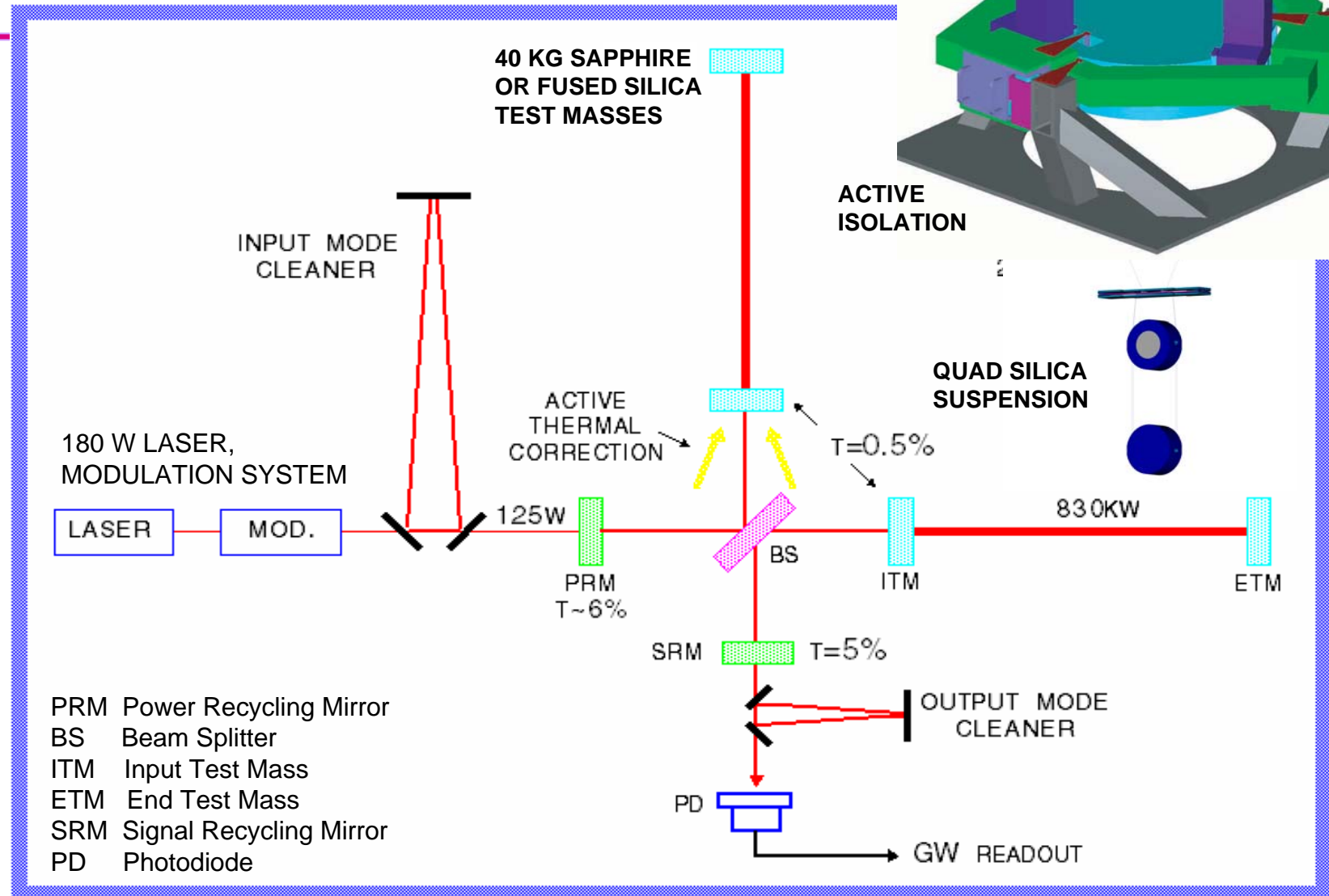

- PRM Power Recycling Mirror
- BS Beam Splitter
- ITM Input Test Mass
- ETM End Test Mass
- SRM Signal Recycling Mirror
- PD Photodiode

Laser

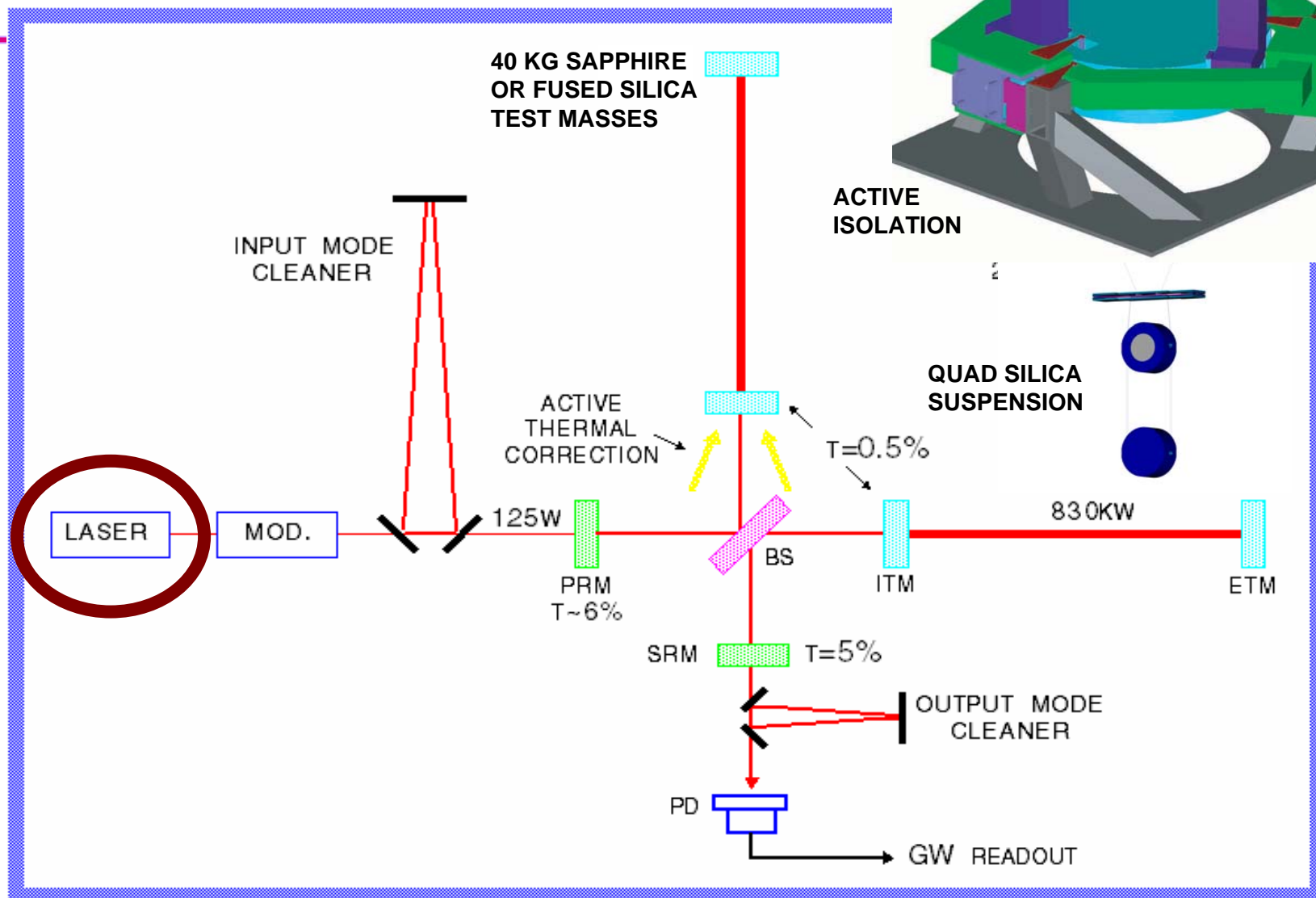
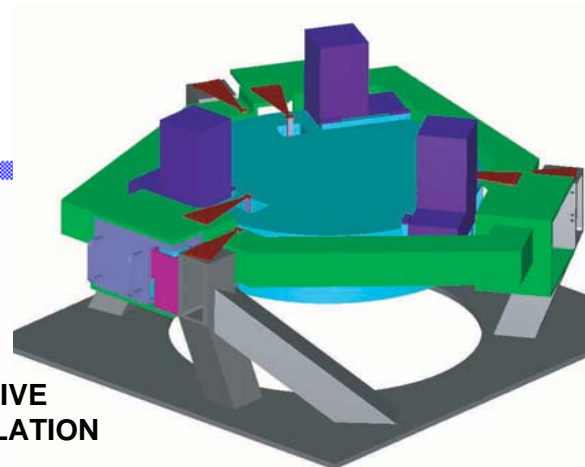

Pre-stabilized laser

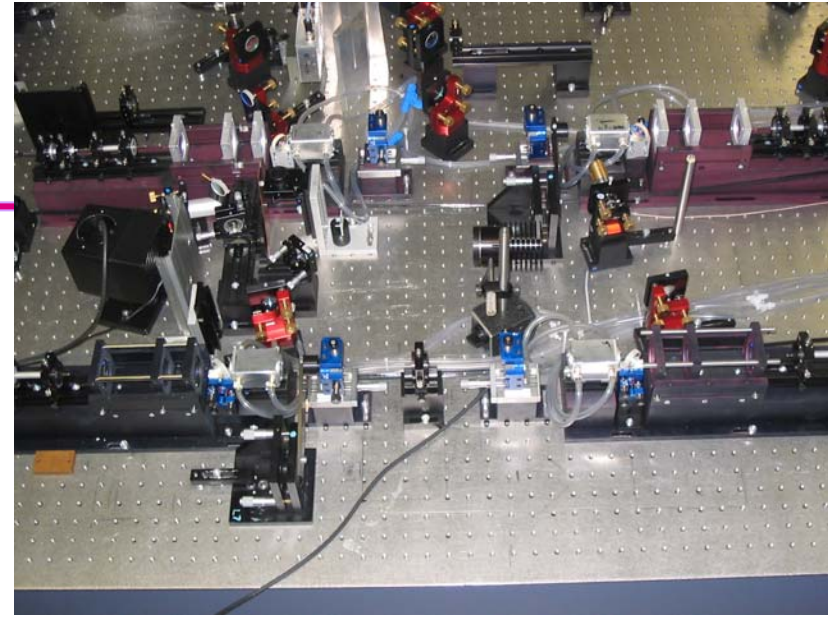

- Max Planck Institute, Hannover leading the Pre-stabilized laser development
 - » Close interaction with Laser Zentrum Hannover
 - » Experience with GEO-600 laser, reliability, packaging
 - » German GEO Group contributing laser to Advanced LIGO
- 2004: Full injection locked master-slave system running, 200 W, linear polarization, single frequency, many hours of continuous operation

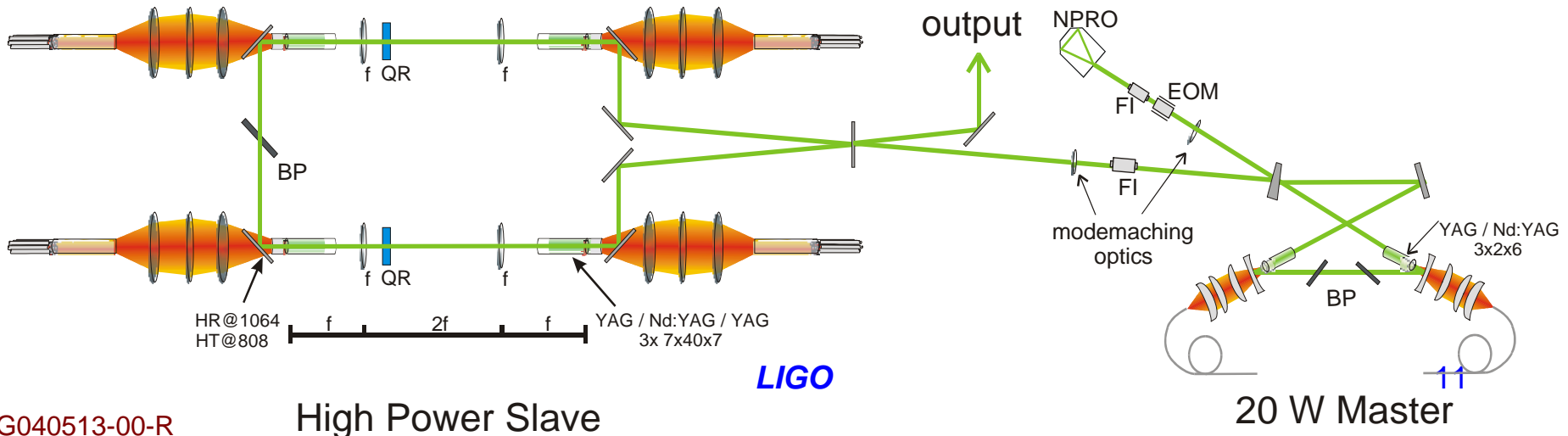

Test Masses

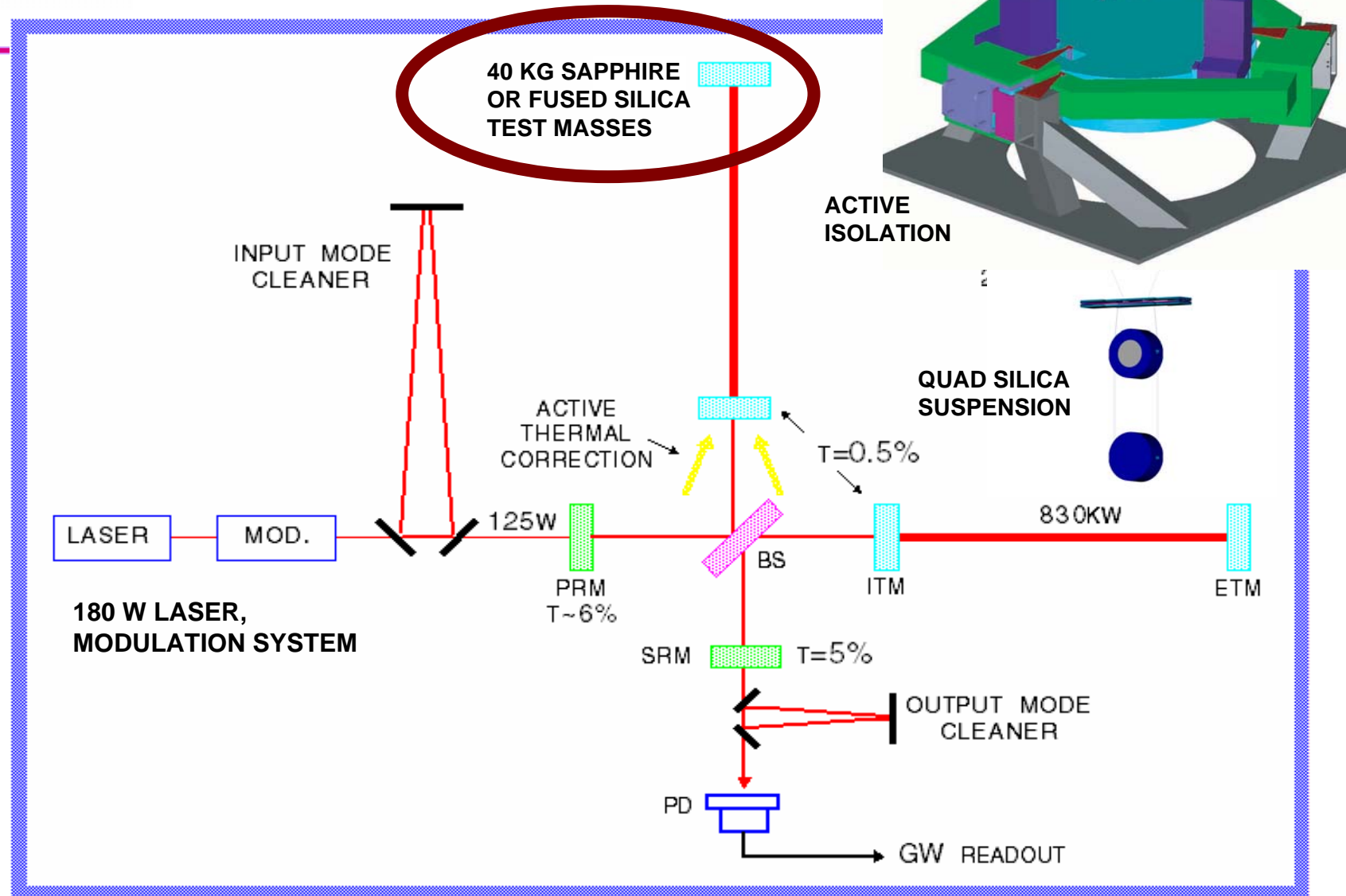

Sapphire Substrates

- Fabrication of Sapphire:
 - » Full-size Advanced LIGO boules grown (Crystal Systems); 31.4 x 13 cm
- Most parameters suitable in large pieces
- 2004: Growing realization of increased risk, uncertainty in getting completed sapphire test masses installed in suspension
- Bulk Absorption:
 - » 2004: further measurement of large pieces
 - » Average level ~60 ppm, 40 ppm desired
 - » Variations large, relatively abrupt, 10-130 ppm
 - » Annealing shown to reduce losses
- 2004: Growing experience with optical coatings
 - » Indications that net optical absorption is greater for best effort; suspect cleanliness or quality of polish
- Mechanical losses: requirement met
 - » Highest Q measured at >250 million
 - » 2004: Direct measurement of thermoelastic noise

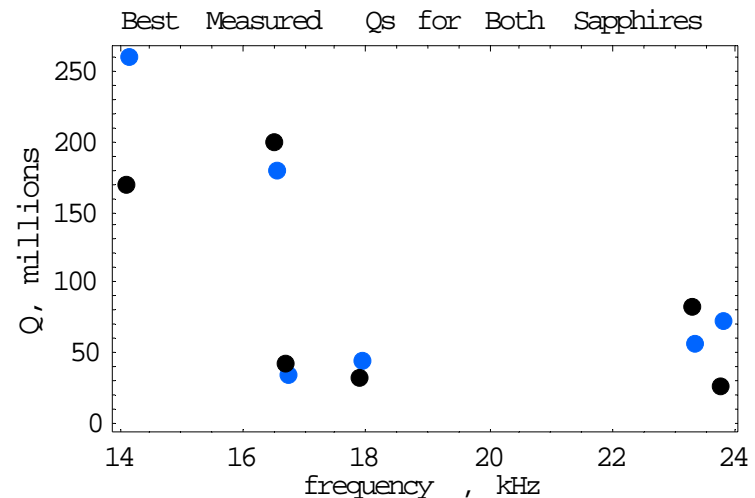
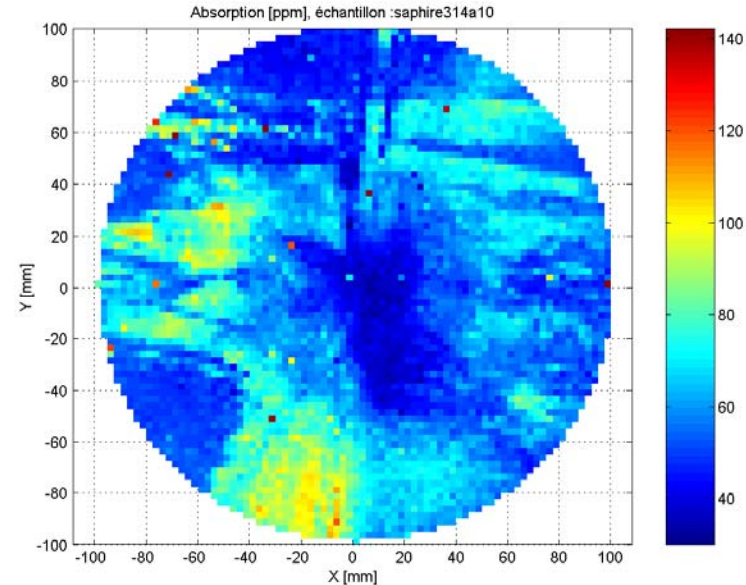

Thermoelastic noise in Sapphire

- Thermoelastic noise – fluctuations in mirror surface due to statistical variations in temperature and coefficient of thermal expansion
- Significant in Sapphire, negligible in Fused Silica
- 2004: **Elegant direct measurements** at Caltech confirm model; followup by Japanese group also agrees
- ‘Pins’ the noise level from a Sapphire-based interferometer

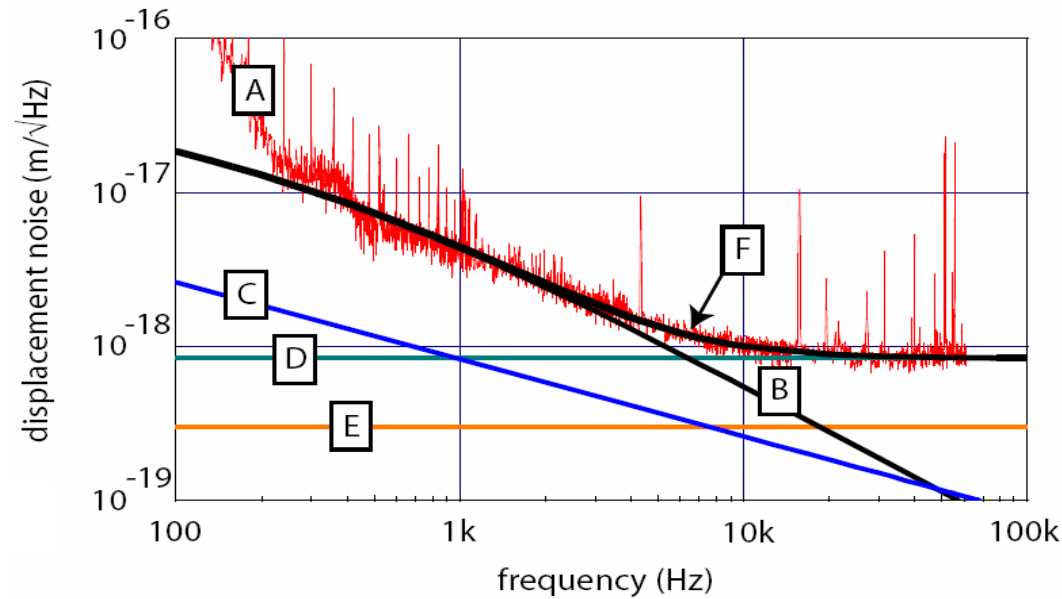
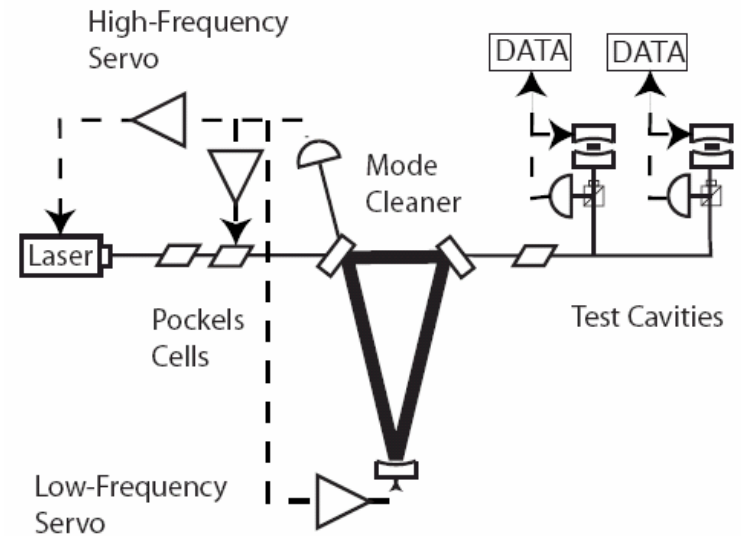



Fused Silica Substrates

- Production of 40 kg pieces with absorption, homogeneity straightforward
- Familiar; fabrication, polishing, coating processes well refined
- Development program to reduce mechanical losses, understand frequency dependence
 - » Annealing proven on small samples, needs larger sample tests and optical post-metrology
- 2004: Assembly of available data of Q vs. Freq, volume/surface (Penn)
 - » Consistent with theory for relaxation process in silica
- Greater range of performance between pessimistic and optimistic parameters

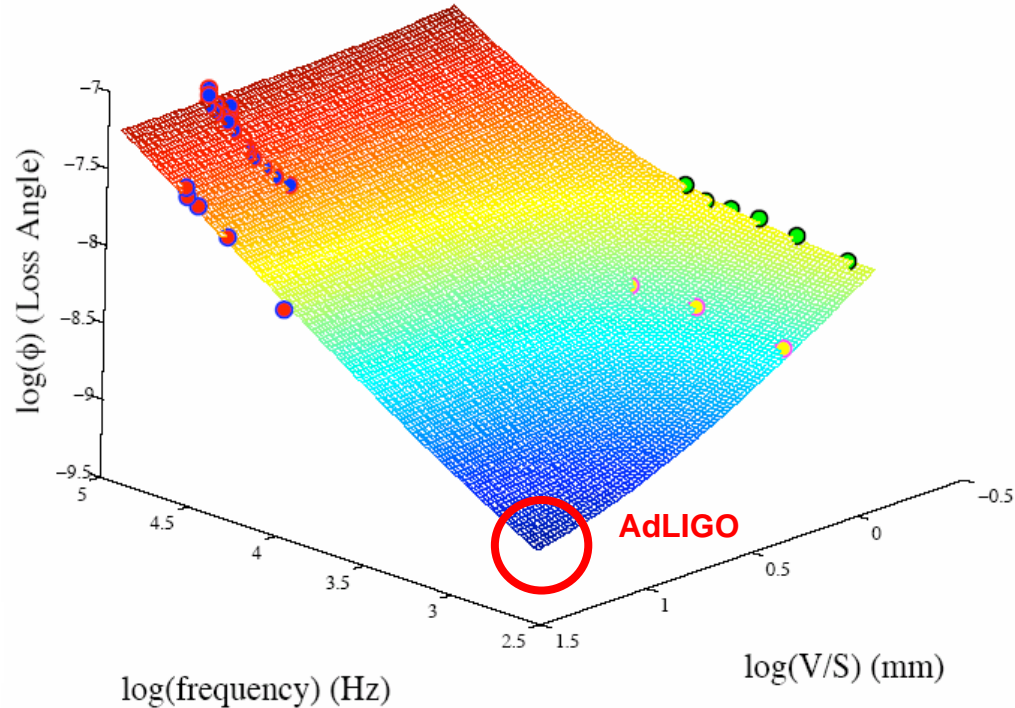
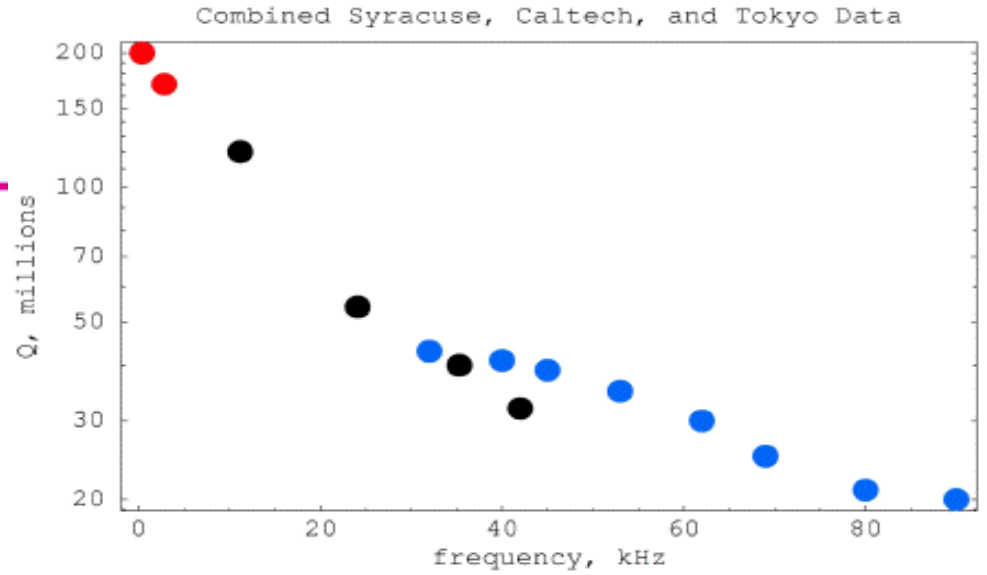



Test Mass downselect

- Delayed
 - » Driven by suspension schedule (UK funding)
 - » Always possible to learn more
- Astrophysics advantages for both substrates
- Risks in production greater for sapphire
- Recent new ingredient: thermal compensation
- Basic suspension design could accommodate either substrate
- Recommendation in coming months

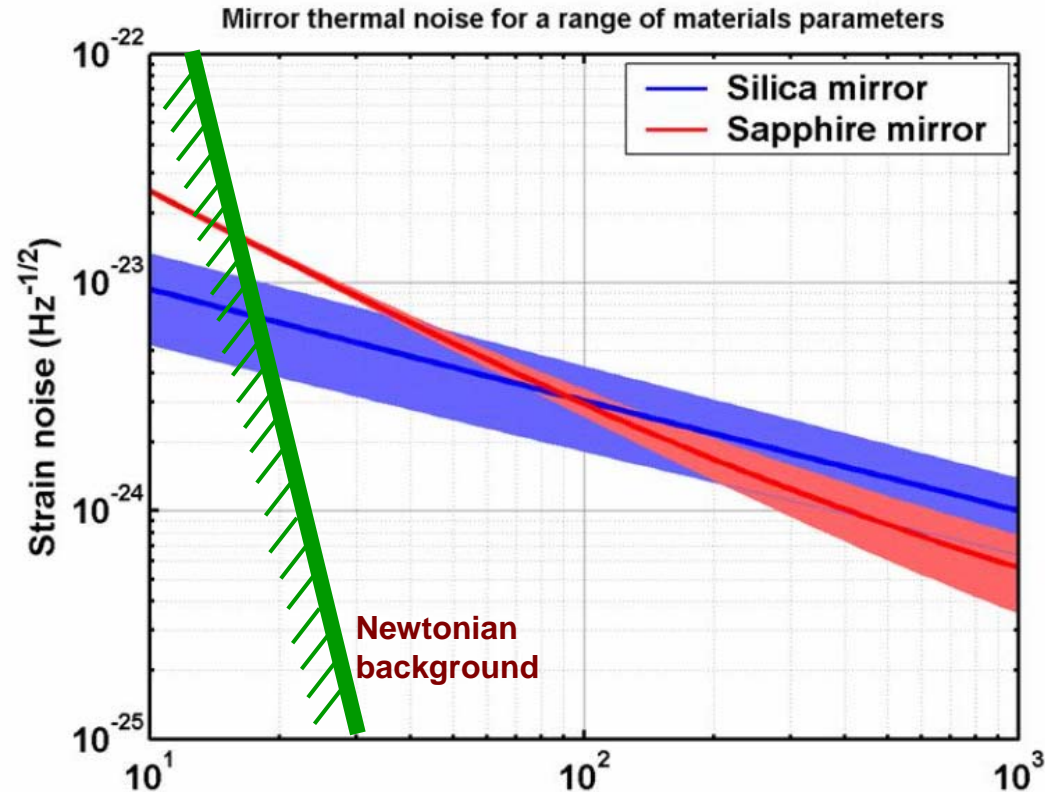

		pessimist - baseline - optimist
NS-NS Mpc	sapphire	165 - 191 - 208
	silica	153 - 191 - 254
10Ms BHBH Mpc	sapphire	762 - 923 - 1016
	silica	775 - 1052 - 1510
XRB, 730 Hz $\times 10^{-25}$	sapphire	9.6 - 6.8 - 4.5
	silica	16 - 12 - 7.2
Stochastic $\times 10^{-9}$	sapphire	1.7 - 1.7 - 1.6
	silica	1.9 - 1.2 - 1.1

- Require low average absorption (0.5 ppm) to limit gaussian-shaped thermal distortion
- Also require freedom from point absorbers to limit inhomogeneous distortion
- 2004: Maps of low-absorption coatings measured in same class-10 room as coating machine (LMA)
- Best results: Average absorption 0.32 ppm
- Only 10 points greater than 0.5 ppm
- Doped coatings and coatings on sapphire need work to match this result (few samples)

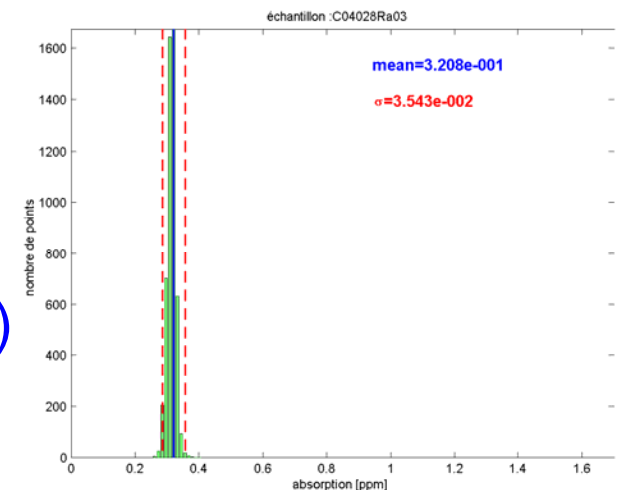
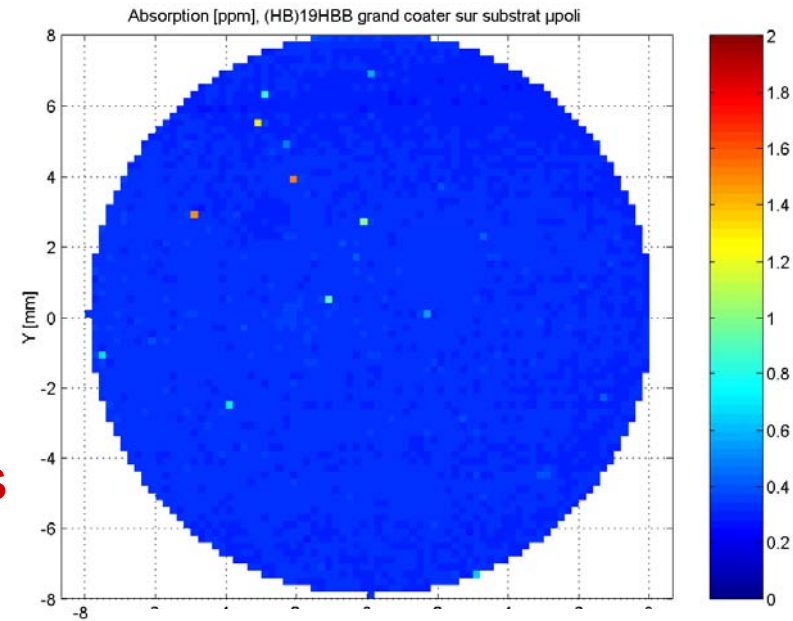

Thermal Compensation

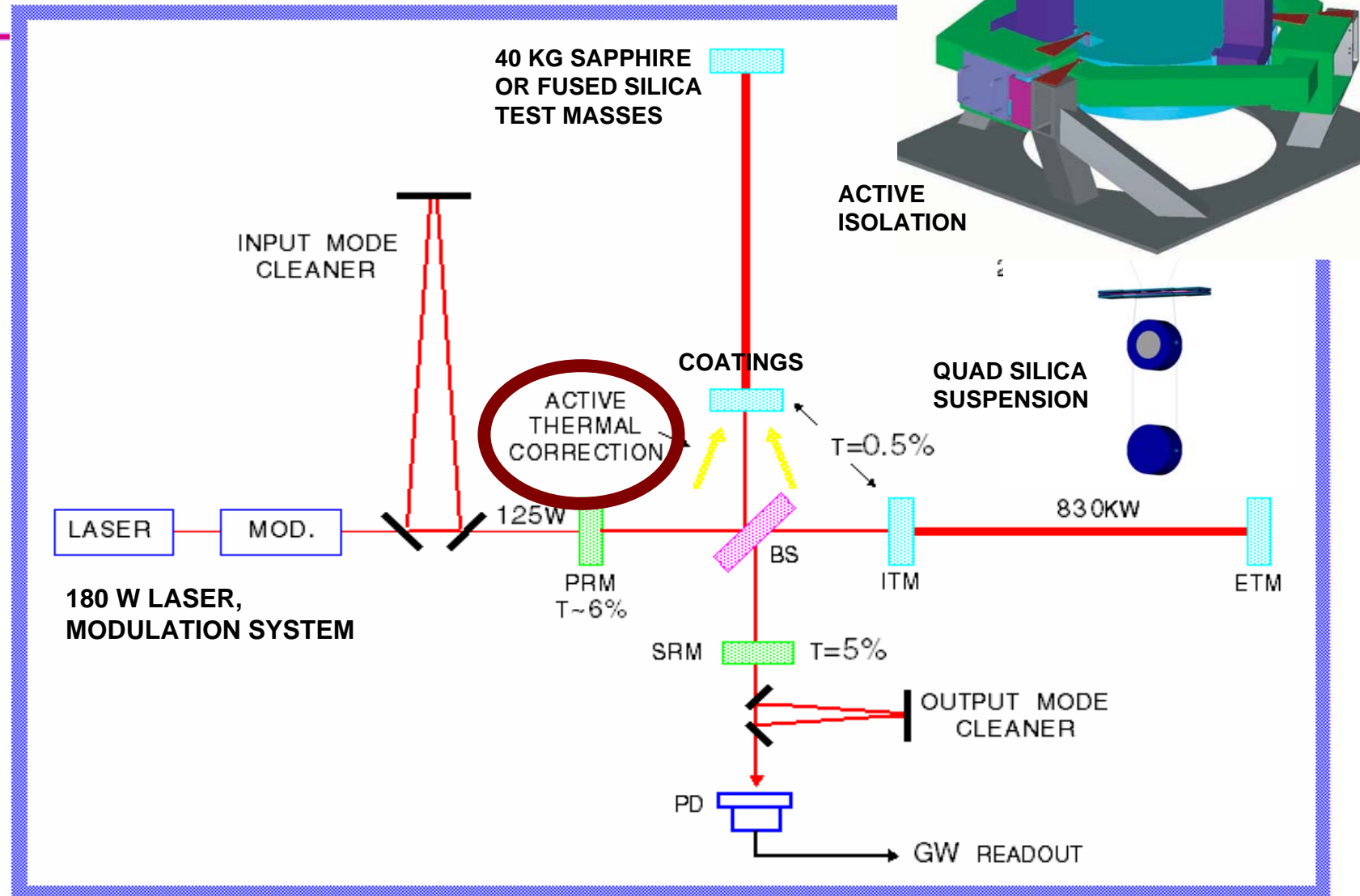

Active Thermal Compensation

- Removes excess 'focus' due to absorption in coating, substrate
- Allows optics to be used at all input powers
- Sophisticated thermal model ('Melody') developed to calculate needs and solution
- 2004: Successful application to initial LIGO using new 'staring' approach
- 2004: Modeling, investigating effect on sidebands and point absorbers
 - » Silica and Sapphire behave differently due to thermal expansion, thermal conductivity differences;
 - » Some (dis)advantages for each, with Silica better on balance for 'clean' coatings

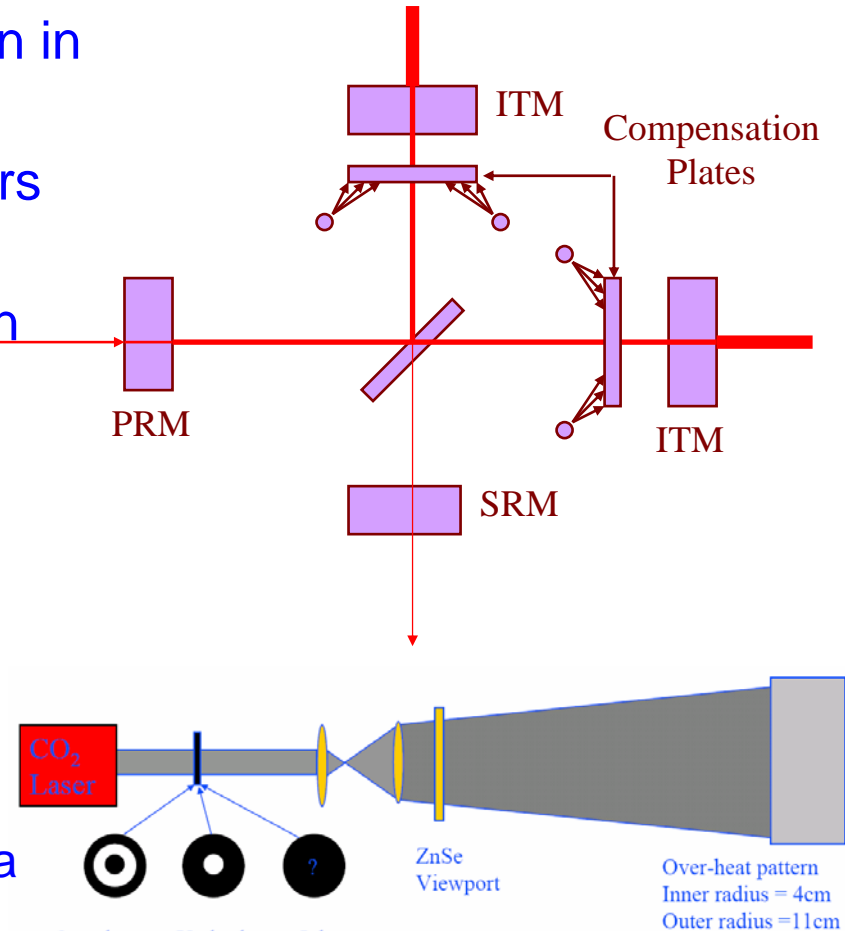

Seismic Isolation

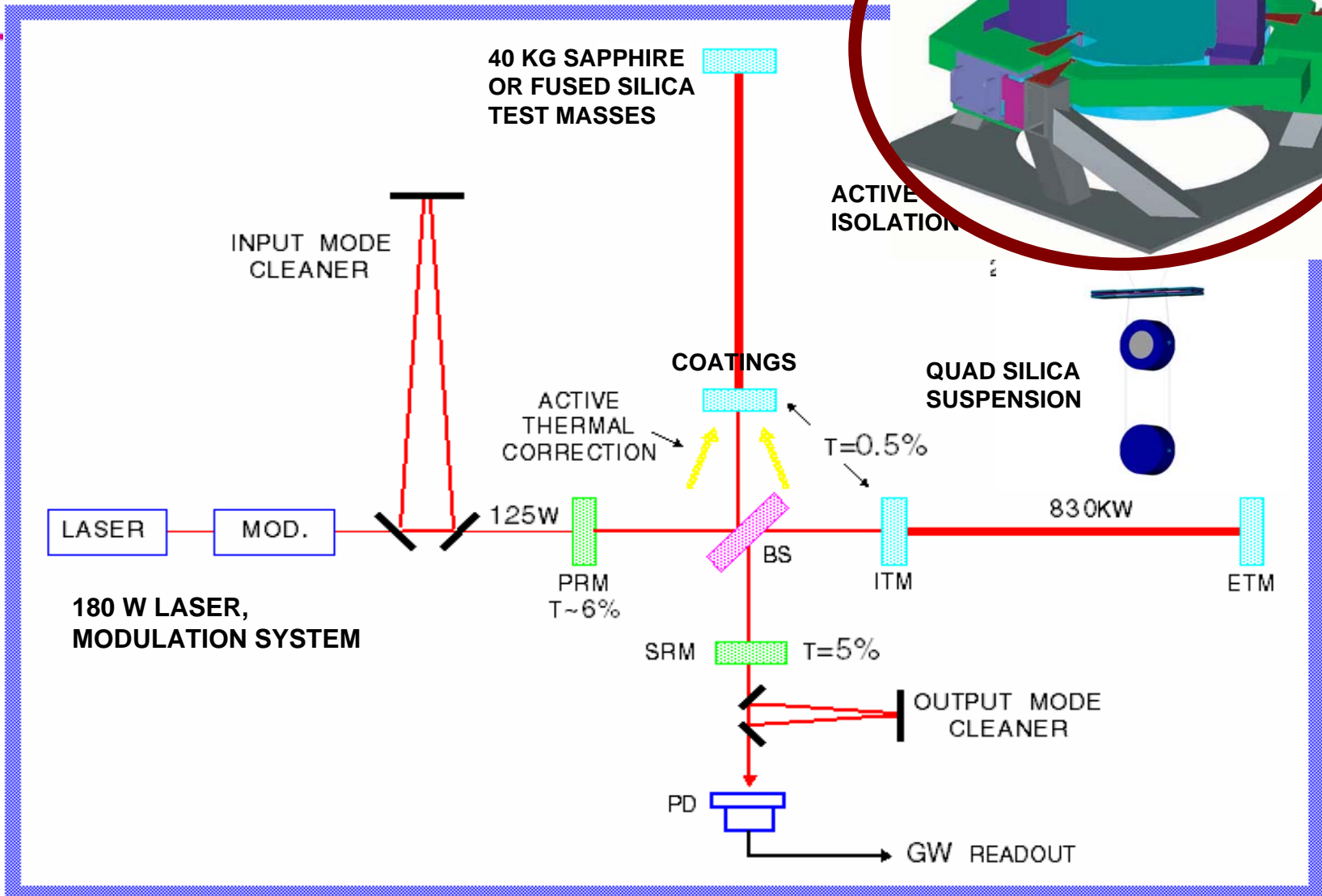
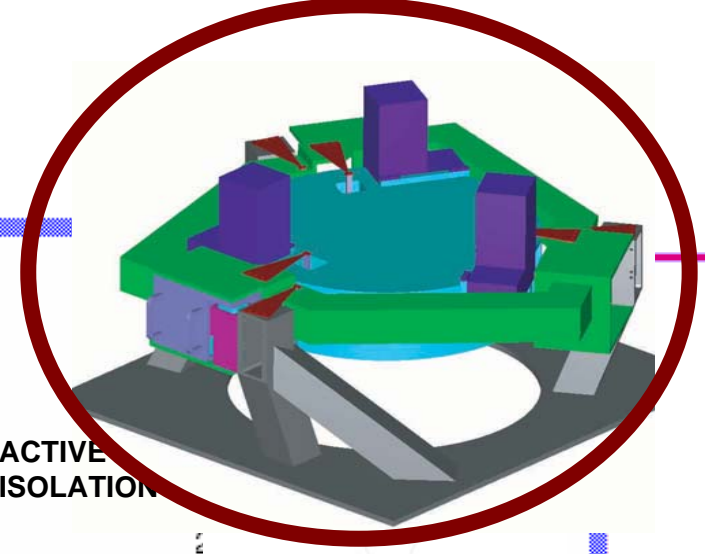

Isolation: multi-stage solution

- Choose an active approach:
 - » high-gain servo systems, two stages of 6 degree-of-freedom each
 - » External hydraulic actuator pre-isolator
 - » Allows extensive tuning of system after installation, operational modes
- Lead at LSU, strong Stanford participation
- 2004: External pre-isolator installed, in commissioning at Livingston
 - » System performance meets initial needs
 - » Exceeds Advanced LIGO requirements

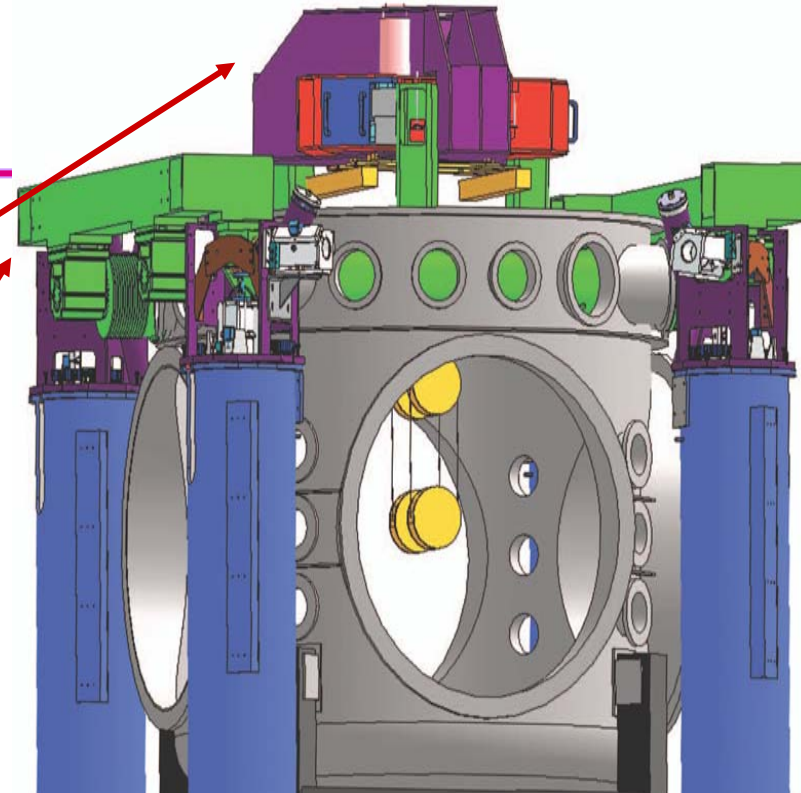

X-arm length disturbance, noisy afternoon

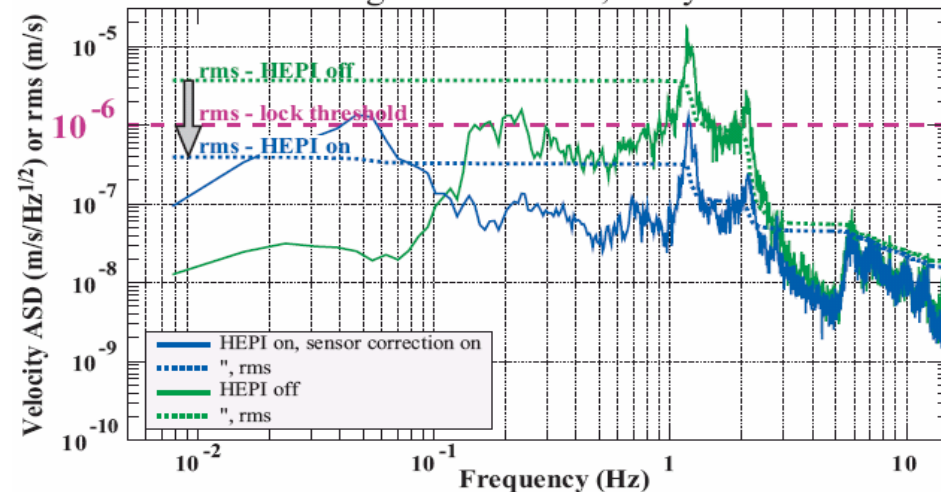

Full-scale prototypes

- 2004: Technology Demonstrator at Stanford in characterization
 - » 1000x Isolation at GW frequencies demonstrated
 - » 1-10 Hz performance next
- Vendor contract for next generation prototype design and prototypes: significant progress in design, but cost increases and schedule delays
- LIGO has chosen to terminate contract at end of design, with plan to take advantage of juncture to review subsystem status and approach and re-bid accordingly
- Critical review Jan-Feb 2005
- Possible that a major shift in direction comes from this review



ETF Performance: X

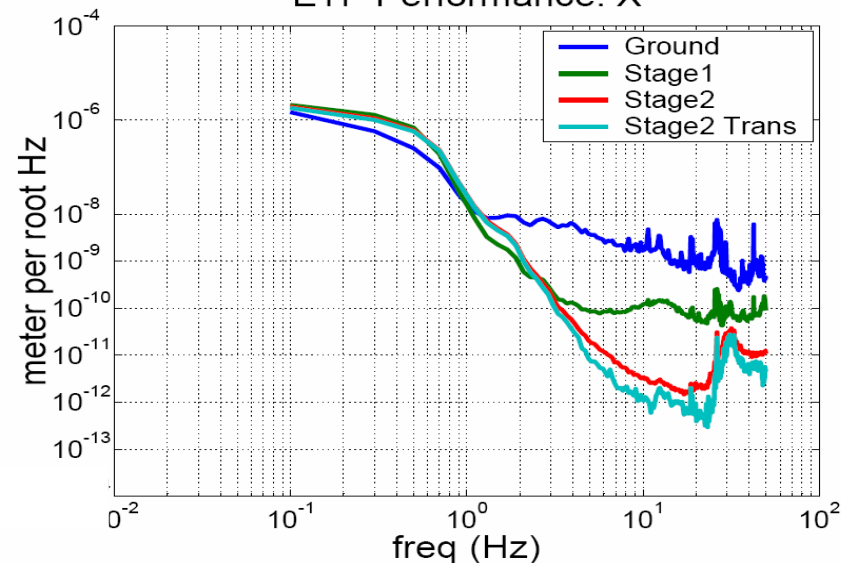

Suspension

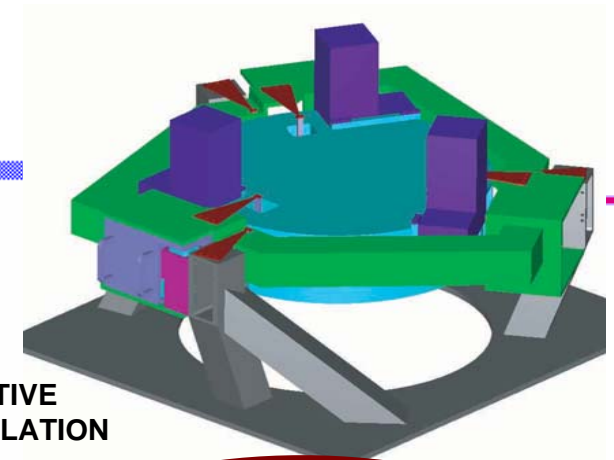
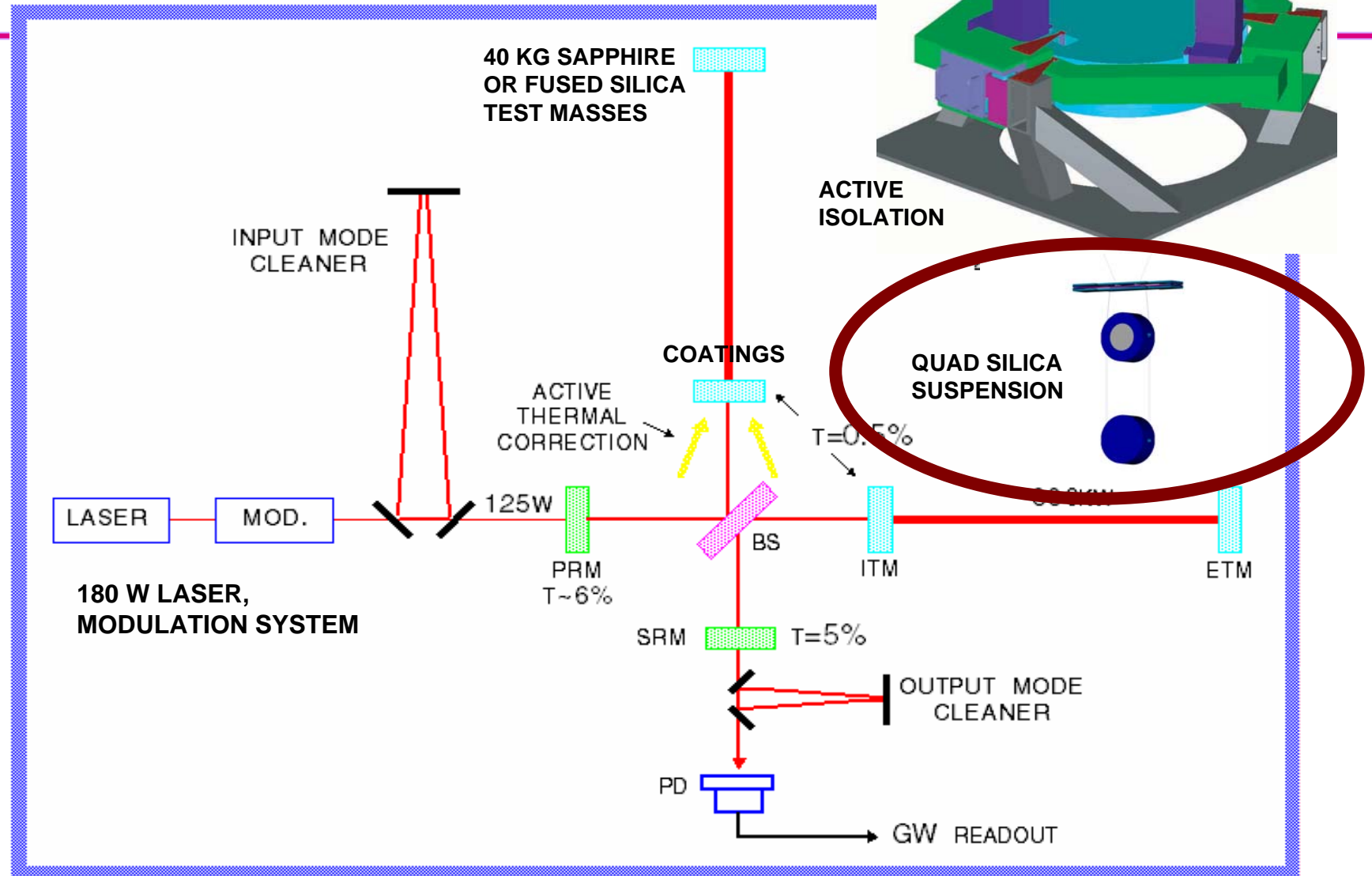

Suspensions: Triples

- Triple suspensions for auxiliary optics
 - » Relaxed performance requirements
- Uses same fused-silica design, control hierarchy
- 2004: Mode Cleaner suspension installed in LASTI full-scale testbed
- Uses HEPI as 'shake table' for excitation
- Characterization of modes, isolation match model nicely



Organization

- LIGO Lab provides management, structure; carries grant for construction and integration/test from NSF
- LSC has key roles in Project phase:
 - » PSL subsystem: Max Planck, anticipated capital partner
 - » Test mass suspensions: U. Glasgow/Rutherford, capital partner
 - » Input Optics: University of Florida
 - » Isolation: Science lead LSU (contracts in-Lab)
 - » Output Optics: ACIGA Australia, anticipated capital partner
- Restructuring of Lab/LSC facilitates assigning responsibility, authority, accountability
- Would like to facilitate additional smaller roles, continuum of LSC contributions through design, fabrication, installation, integration/test
- May require more contracts with Lab, or ‘peeling off’ more smaller tasks to more smaller groups

Next

- Test mass selection (Dec 2004), pathfinder fabrication of test mass optics (all of 2005)
- Critical review of BSC seismic isolation (Jan/Feb 2005), contracting for final prototype (all of 2005); review of HAM approach (mid-2005)
- Installation/test of all-metal quad suspension in LASTI testbed (May 2005 and onward)
- Locking (imminent), exploitation of 40m interferometry testbed (all of 2005)
- Continued cost/schedule refinement, linking with Caltech finances, flexible planning for melding with Operations support
- Probable internal (Lab/ review of Advanced LIGO technical and programmatic status (mid-2005)
- Really looking forward to wind-down of initial LIGO commissioning and wind-up of Advanced LIGO!