

LASER INTERFEROMETER GRAVITATIONAL WAVE OBSERVATORY
- LIGO -
CALIFORNIA INSTITUTE OF TECHNOLOGY
MASSACHUSETTS INSTITUTE OF TECHNOLOGY

LIGO-T980080-A - E 09-08-98
LIGO CONTROL & MONITORING SYSTEM RELIABILITY PREDICTION REPORT
LIGO Systems Engineering

This is an internal working note
of the LIGO Project.

California Institute of Technology
LIGO Project - MS 18-34
Pasadena CA 91125
Phone (626) 395-2129
Fax (626) 304-9834
E-mail: info@ligo.caltech.edu

Massachusetts Institute of Technology
LIGO Project - MS 20B-145
Cambridge, MA 01239
Phone (617) 253-4824
Fax (617) 253-7014
E-mail: info@ligo.mit.edu

WWW: <http://www.ligo.caltech.edu/>

TABLE OF CONTENTS

	ABSTRACT	4
1.0	INTRODUCTION	5
2.0	ACRONYMS	6
3.0	APPLICABLE DOCUMENTS	7
4.0	RELIABILITY REQUIREMENTS	8
5.0	RELIABILITY ANALYSES	10
5.1	RELIABILITY MODELING	10
5.2	RELIABILITY PREDICTION	11
5.3	AVAILABILITY PREDICTION	11
6.0	CONCLUSIONS	16
APPENDIX A:		
CM AVAILABILITY PREDICTION,		
HANFORD, WA		
		17
APPENDIX B:		
CM AVAILABILITY PREDICTION,		
LIVINGSTON, LA		
		29
APPENDIX C:		
LIGO 3X		
CM AVAILABILITY PREDICTION		
		38
APPENDIX D:		
LIGO 2X		
CM AVAILABILITY PREDICTION		
		40
APPENDIX E:		
LIGO 1X		
CM AVAILABILITY PREDICTION		
		42

LIST OF TABLES

Table 1:	Project Documents	7
Table 2:	Reliability Standards and Handbooks.....	7
Table 3:	Reliability Software	7
Table 4:	LIGO System Reliability Requirements.....	8
Table 5:	Subsystem Availability Allocations	9
Table 6:	Reliability Data Sources	15
Table 7:	Interferometer CM Availability Prediction Results	16
Table 8:	CM Availability Predictions For The LIGO Operating Modes	16

LIST OF FIGURES

Figure 1: CM Reliability Block Diagram For The LIGO 3X Operating Mode	12
Figure 2: CM Reliability Block Diagram For The LIGO 2X Operating Mode	13
Figure 3: CM Reliability Block Diagram For The LIGO 1X Operating Mode	14

ABSTRACT

A reliability prediction was performed on the LIGO Control and Monitoring (CM) System. Where vendor data was not available, engineering estimates were made based upon equipment complexity, NPRD-95 data and vendor data on similar equipment. In addition, LIGO and JPL Network Administrators were interviewed to utilize their experience in the determining of the failure rates assigned to computer and computer peripheral hardware.

The CM consists primarily of computer type equipment and rack mounted modular electronic assemblies. On-line diagnostics capabilities and fault indications have been designed into the CM to ease the fault detection, fault localization and fault isolation process. It is assumed that a sufficient electronic module spares inventory will be available at each observatory. Taking into consideration the on-line diagnostics capability, the modular design concept and the availability of spares, the Mean-Down-Time (MDT) associated with a CM repair action should be minimal. Therefore, a CM MDT value of 8.0 hours was used for the availability predictions.

A fault tree was developed and an Availability prediction was performed on the CM at the Washington Observatory. The Washington Observatory CM consists of the HIF1 CM, the HIF2 CM, and the HCMN CM. A fault tree was also developed and an Availability prediction was also performed on the CM at the Louisiana Observatory. The CM at the Louisiana Observatory consists of the LIF1 CM.

The fault tree and detailed calculations for the HIF1 CM, the HIF2 CM, and the HCMN CM are provided in Appendix A. The fault tree and detailed calculations for the LIF1 CM are provided in Appendix B. Availability predictions were then performed for the three LIGO operating modes. The fault trees and Availability predictions for the three LIGO operating modes are provided in Appendices C through E. The results of the CM availability predictions for each of the LIGO operating modes are summarized in the table below.

CM Availability Predictions For The LIGO Operating Modes

<i>Mode of Operation</i>	<i>Allocated Annual Availability</i>	<i>Predicted Annual Availability</i>
3X	0.9959	0.9937
2X	0.9980	0.9959
1X	1.0000	1.0000

1.0 INTRODUCTION

Reliability, repair time and availability calculations were performed on the Control & Monitoring System (CM) of the Laser Interferometer Gravitational Wave Observatory (LIGO). Failure rate data was obtained from the following sources:

- Vendor data
- “Non-Electronic Parts Reliability Data 1995,” NPRD-95, Reliability Analysis Center
- Engineering estimates predicated upon experience with equipments of similar complexity.

The calculations were predicated upon the design information available at the time this report was prepared. This report will be updated to reflect the current design if the differences in design or material/part selection are likely to significantly impact reliability or availability.

2.0 ACRONYMS

A	Operational Availability
ADC	Analog/Digital Converter
ASC	Alignment Sensing and Control
Assy	Assembly
CMN	Common
CM	Control & Monitoring
FPMH	Failures Per Million Hours
FTA	Fault Tree Analysis
GPS	Global Positioning System
H	Hanford, Washington site
IFODS	Interferometer Diagnostics System
IF1	Interferometer, 4 km long
IF2	Interferometer, 2 km long
L	Livingston, Louisiana site
LIGO	Laser Interferometer Gravitational Wave Observatory
LVEA	Laser Vacuum Equipment Area
MDT	Mean Down Time
MTBF	Mean Time Between Failure (λ^{-1})
N/A	Not Applicable
OSB	Operational Support Building
P.C.	Personal Computer
Q	Operational Unavailability (1 - A)
λ	Failure Rate

3.0 APPLICABLE DOCUMENTS

The documents containing CM design requirements, CM design, LIGO reliability requirements and guidelines, reliability modeling and prediction methods, and the software used to perform the reliability predictions and availability calculations are listed in the tables below.

Table 1: Project Documents

LIGO-E960099-B-E	LIGO Reliability Program Plan
LIGO-T950054-01-Cxx	CDS Control and Monitoring Design Requirements
LIGO-T970171-00-CFD	CDS Control and Monitoring Final Design
LIGO-G970289-00-C	CDS Control & Monitoring Final Design Review (FDR)
LIGO - E950018-02-E	LIGO Science Requirements Document

Table 2: Reliability Standards and Handbooks

MIL-STD-785	Reliability Program for Systems and Equipment Development and Prediction
MIL-STD-756	Reliability Modeling and Prediction
NRPD-95	Non-Electronic Parts Reliability Data 1995, Reliability Analysis Center

Table 3: Reliability Software

ITEM Software FaultTree+	Fault tree analysis software; Availability calculations
--------------------------	---

4.0 RELIABILITY REQUIREMENTS

The LIGO top level system availability requirements are summarized in Table 4 below:

Table 4: LIGO System Reliability Requirements

<i>Mode of Operation</i>	<i>Annual Availability</i>	<i>Minimum Continuous Operating Period</i>
3X	75%	100 hours
2X	85%	100 hours
1X	90%	40 hours

The Modes of Operation are defined as:

- a. Triple Operations Mode (3X): All three interferometers are operational.
- b. Double Operations Mode (2X): At least two interferometers are operational. One of which must be the Louisiana interferometer.
- c. Single Operations Mode (1X): At least one of the three interferometers is operational.

As described in the LIGO Reliability Program Plan, the allocated subsystem availability requirements were derived from the observatory availability requirements for the 3X mode of operation. With respect to availability, the 3X mode of operation represents the worst case operating scenario. For the reader's convenience, the subsystem availability requirements are presented in Table 5 on page 9. The CM availability requirements are highlighted. In the process of allocating the subsystem availability requirements, it was assumed that the 4 km and the 2 km interferometers were of equal complexity. Therefore, since there are two interferometers at the Washington Observatory, the subsystems at the Washington Observatory were assumed to be twice as complex as the respective subsystems at the Louisiana Observatory. As a result, the Washington Observatory subsystem Mean-Time-Between-Mission-Critical-Failure (MTBMCF) values are half of the respective subsystem MTBMCF values at the Louisiana Observatory. The Beam Tube, Facilities Monitoring and Control System, Heating, Ventilation and Air Conditioning, and Electrical Power are exceptions to this rule. These four subsystems were considered to be of equal complexity at each observatory.

MTBMCF is the mean time between subsystem failures which would jeopardize the collection and validation of science data. The MTBMCF takes into consideration equipment redundancies which might be present within the subsystem.

Table 5: Subsystem Availability Allocations

<i>SUBSYSTEM</i>	<i>OBSERVATORY</i>					
	<i>LOUISIANA</i>			<i>WASHINGTON</i>		
	<i>MTBMCF (Op. Hours)</i>	<i>MDT (Hours)</i>	<i>A</i>	<i>MTBMCF (Op. Hours)</i>	<i>MDT (Hours)</i>	<i>A</i>
CDS C&M	17, 600	24	0.9986	8, 800	24	0.9973
CDS CM	17, 600	24	0.9986	8, 800	24	0.9973
CDS Infrastructure	17, 600	24	0.9986	8, 800	24	0.9973
VCMS	17, 600	24	0.9986	8, 800	24	0.9973
ASC	20, 000	72	0.9964	10, 000	72	0.9929
LSC	20, 000	72	0.9964	10, 000	72	0.9929
COC	26, 000	72	0.9972	13, 000	72	0.9945
COS	24, 000	72	0.9970	12, 000	72	0.9940
IOO	10, 000	72	0.9929	5, 000	72	0.9858
PSL	5, 000	72	0.9858	2, 500	72	0.9720
SEI	13, 000	72	0.9945	6, 500	72	0.9890
SUS	13, 000	72	0.9945	6, 500	72	0.9890
PEM	17, 600	24	0.9986	8, 800	24	0.9973
BT	35, 000	1, 460	0.9600	35, 000	1, 460	0.9600
FMCS	17, 600	24	0.9986	17, 600	24	0.9986
HVAC	17, 600	72	0.9959	17, 600	72	0.9959
ELEC. PWR.	8, 800	24	0.9973	8, 800	24	0.9973
VE	8, 800	72	0.9919	4, 400	72	0.9839

Mean-Down-Time (MDT) is the total preventive and corrective maintenance time divided by the total number of preventive and corrective maintenance actions for a given subsystem. Logistic delays are included in the calculation of preventive and corrective maintenance times. The subsystem MDT requirements are based upon subsystem size, complexity, and the fact that some subsystems may require a bake-out following maintenance actions. The MDT requirement should be used as a guide in the development of on-site spares and maintenance support policies.

Availability is defined as the ability of an item, under the combined aspects of its reliability and maintenance, to perform its required function over a given period of time. Mathematically, Availability is approximated as:

$$A = \frac{MTBMCF}{MTBMCF + MDT}$$

Therefore, since availability allows for trade-offs between reliability (MTBMCF) and maintenance (MDT), the subsystem availability allocations are the design constraints which must be met in order to achieve the desired level of observatory availability.

5.0 RELIABILITY ANALYSES

CM reliability was assessed by means of:

- Reliability Modeling
- Reliability and Availability Predictions
- Fault Tree Analysis

5.1 RELIABILITY MODELING

The CM Reliability Block Diagram for the LIGO 3X Operating Mode is shown in Figure 1. The Reliability Block Diagram depicts a series model in which it is necessary for the CM at both of the observatories to be operational for successful LIGO 3X operation. At the Hanford Observatory, CM equipment interfaces with and provides real-time control of the LIGO equipment peculiar to the 4km Interferometer (HIF1 CM) and the 2km Interferometer (HIF2 CM). In addition, there is CM equipment that is common to the interface and real-time control of both interferometers (HCMN CM). At the Livingston Observatory, CM equipment interfaces with and provides real-time control of the LIGO equipment peculiar to a 4km Interferometer (LIF1 CM).

The CM Reliability Model for the LIGO 2X Operating Mode is shown in Figure 2. The combination series/parallel model illustrates that at least the HIF1 CM or the HIF2 CM must be operational along with the HCMN CM and the LIF1 CM for successful LIGO 2X operation.

The CM Reliability Model for the LIGO 1X Operating Mode is shown in Figure 3. This combination series/parallel model depicts that one, or more, of the following conditions must be met for successful LIGO 1X operation:

- HIF1 CM “AND” HCMN CM
- HIF2 CM “AND” HCMN CM
- LIFI CM

5.2 RELIABILITY PREDICTION

A reliability prediction was performed on the CM. Where vendor data was not available, engineering estimates were made based upon equipment complexity, NPRD-95 data and vendor data on similar equipment. In addition, LIGO and JPL Network Administrators were interviewed to utilize their experience in the determining of the failure rates assigned to computer and computer peripheral hardware.

Table 6 on page 15 identifies the various CM equipments, the equipment MTBFs and the source of the MTBF values.

5.3 AVAILABILITY PREDICTION

Availability predictions were performed by developing fault trees using the FaultTree+ software. A fault tree was developed and an Availability prediction was performed on the CM at the Washington Observatory. The Washington Observatory CM consists of the HIF1 CM, the HIF2 CM, and the HCMN CM. A fault tree was also developed and an Availability prediction was also performed on the CM at the Louisiana Observatory. The CM at the Louisiana Observatory consists of the LIFI CM.

The CM consists primarily of computer type equipment and rack mounted modular electronic assemblies. On-line diagnostics capabilities and fault indications have been designed into the CM to ease the fault detection, fault localization and fault isolation process. It is assumed that a sufficient electronic module spares inventory will be available at each observatory. Taking into consideration the on-line diagnostics capability, the modular design concept and the availability of spares, the MDT associated with a CM repair action should be minimal. Therefore, a CM MDT value of 8.0 hours was used for the availability predictions rather than the previously allocated MDT of 24.0 hours.

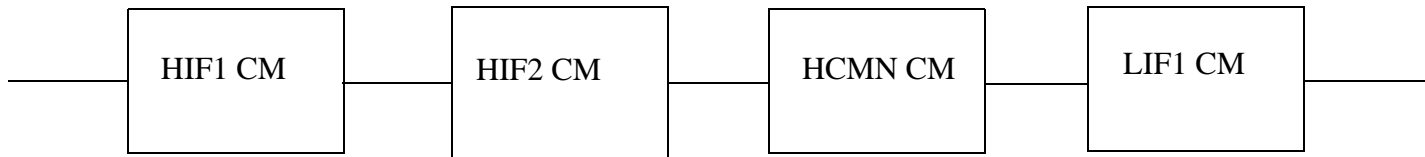

Figure 1: CM Reliability Block Diagram For The LIGO 3X Operating Mode

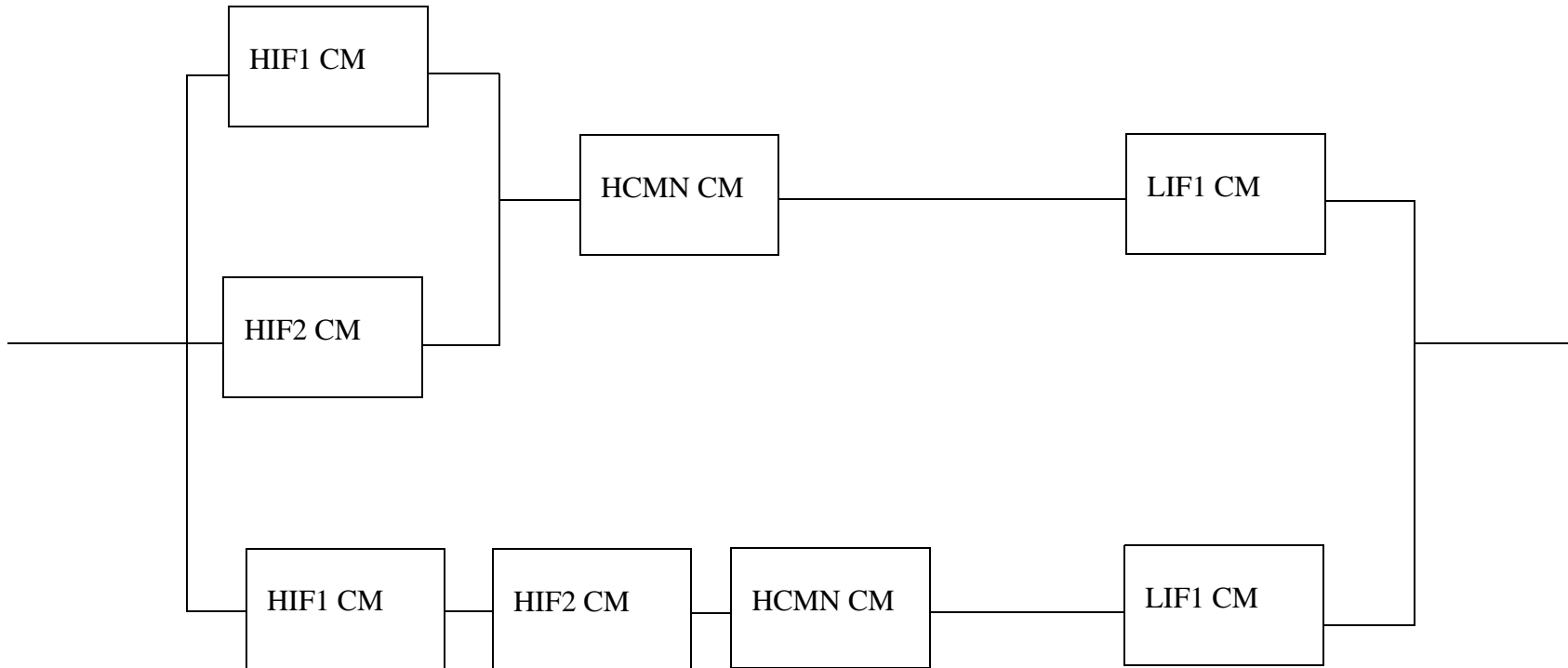

Figure 2: CM Reliability Block Diagram For The LIGO 2X Operating Mode

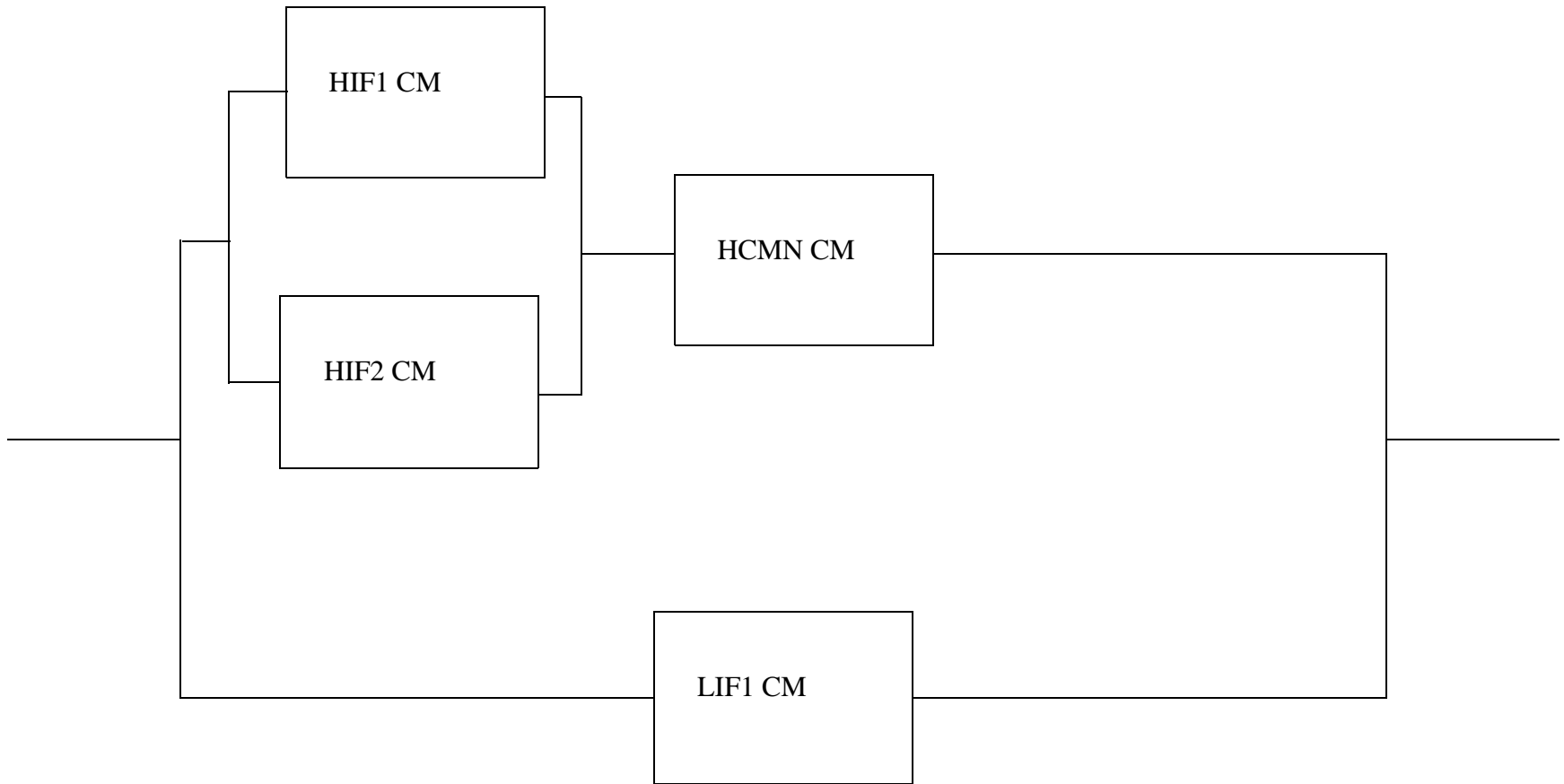

Figure 3: CM Reliability Block Diagram For The LIGO 1X Operating Mode

Table 6: Reliability Data Sources

<i>Description</i>	<i>Failure Rate (λ) (FPMH)</i>	<i>MTBF (Hours)</i>	<i>Source</i>
ASX-1000 ATM Switch	22.8311	43, 800	Engineering Estimate
AVA-300 Video Uplink	22.8311	43, 800	Engineering Estimate
ES-3810 Ethernet Switch	22.8311	43, 800	Engineering Estimate
Baja 4700 CPU Module	2.8454	351, 448	Vendor
Xycom 212 Binary Input Module	10.0000	100, 000	Vendor
ICS-110B ADC Module	23.8095	42, 000	Vendor
Filter, Signal Conditioning	10.3520	96, 600	Engineering Estimate
Antenna, GPS	3.7272	268, 298	NPRD-95
Brandywine GPS Module	20.0000	50, 000	Engineering Estimate
Keyboard, Computer	38.0518	26, 280	Engineering Estimate
Knob Box, Computer	38.0518	26, 280	Engineering Estimate
Memory, Hard Disk, Computer	45.6621	21, 900	Engineering Estimate
Monitor, Computer	32.6158	30, 660	Engineering Estimate
Mouse, Computer	38.0518	26, 280	Engineering Estimate
Workstation, P.C.	91.3242	10, 950	Engineering Estimate
Workstation / Server, UNIX	22.8311	43, 800	Engineering Estimate

The fault tree and detailed calculations for the HIF1 CM, the HIF2 CM, and the HCMN CM are provided in Appendix A. The fault tree and detailed calculations for the LIF1 CM are provided in Appendix B. A summary of the results is shown in Table 7 below:

Table 7: Interferometer CM Availability Prediction Results

<i>CM</i>	<i>Unavailability (Q)</i>	<i>Availability (A = 1-Q)</i>
HIF1	1.110e-3	0.9989
HIF2	1.110e-3	0.9989
HCMN	1.494e-3	0.9985
LIF1	2.603e-3	0.9974

Availability predictions were then performed for the three LIGO operating modes. Fault trees for the three LIGO operating modes were developed using the results of the HIF1 CM, HIF2 CM, HCMN CM and the LIF1 CM availability predictions. The fault trees and Availability predictions for the three LIGO operating modes are provided in Appendices C through E. The results of the CM availability predictions for each of the LIGO operating modes are summarized in Table 8 below.

Table 8: CM Availability Predictions For The LIGO Operating Modes

<i>Mode of Operation</i>	<i>Allocated Annual Availability</i>	<i>Predicted Annual Availability</i>
3X	0.9959	0.9937
2X	0.9980	0.9959
1X	1.0000	1.0000

6.0 CONCLUSIONS

The CM predicted availability for the LIGO 3X and 2X operating modes is slightly less than the CM allocated availability. However, for all practical purposes, the predicted CM availability equals the allocated CM availability. As the maintenance and spares policy becomes more defined and as additional vendor reliability data becomes available, refinements to this analysis will be made which should help increase the overall CM availability even further.

In addition, a CM prototype has been operating at the 40M Model since approximately August 1995. The CM prototype has been operating 24 hours per day and has not experienced a hardware failure. The prototype is very similar to the CM to be deployed at the observatories with the primary difference being that the prototype has fewer interface points to monitor. The feasibility of incorporating CM prototype test data into the reliability/availability analyses will be evaluated. Utilization of test data, in the determination of equipment and module MTBF values, may result in a more accurate reliability/availability assessment of the CM.

***APPENDIX A:
CM AVAILABILITY PREDICTION,
HANFORD, WA***

NOTES:

1. M = Mean-Time-Between-Failure (MTBF) in hours.
2. F = Fixed Unavailability
3. MDT = Mean-Down-Time = 8.0 hours unless stated otherwise.

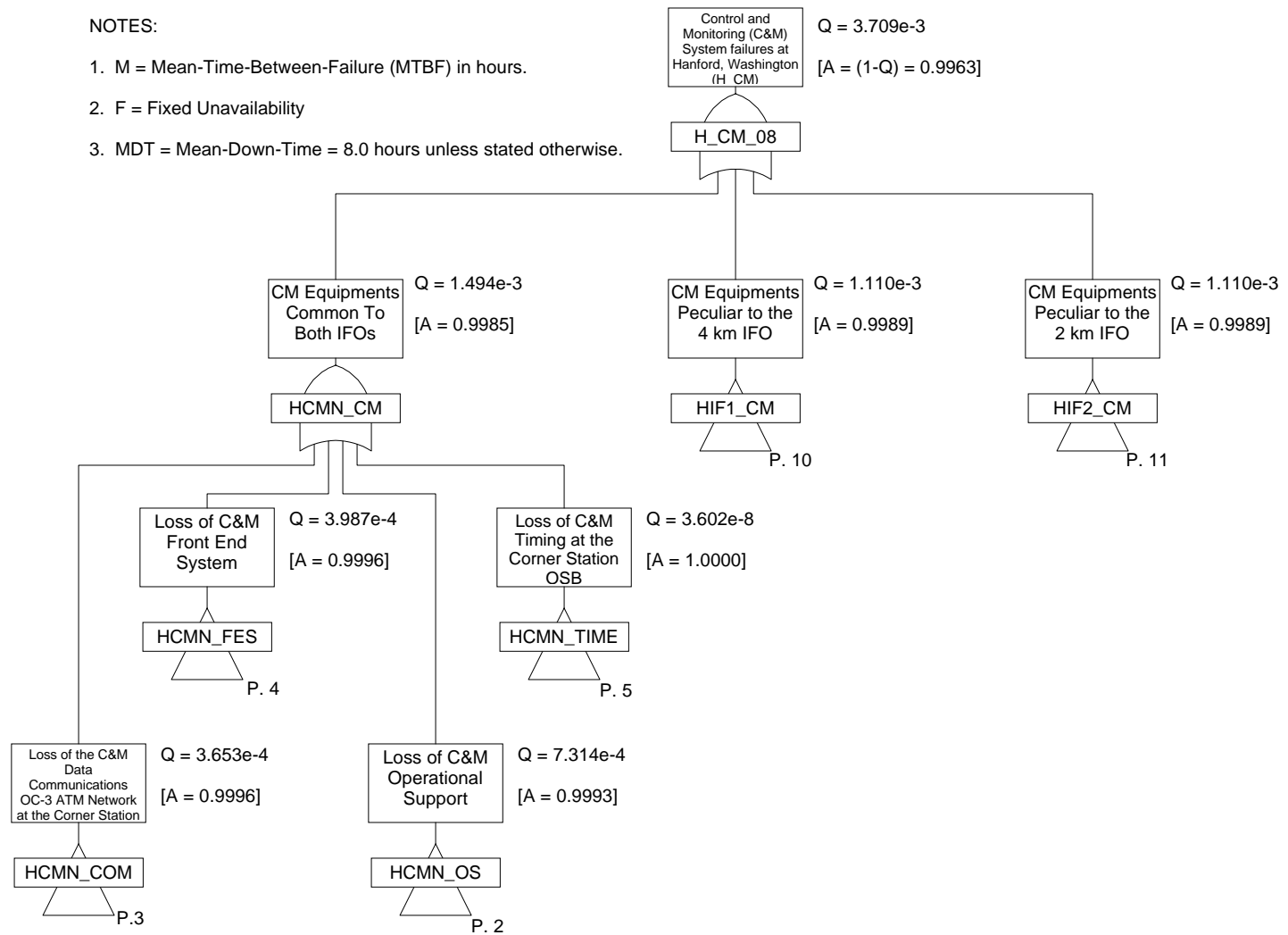

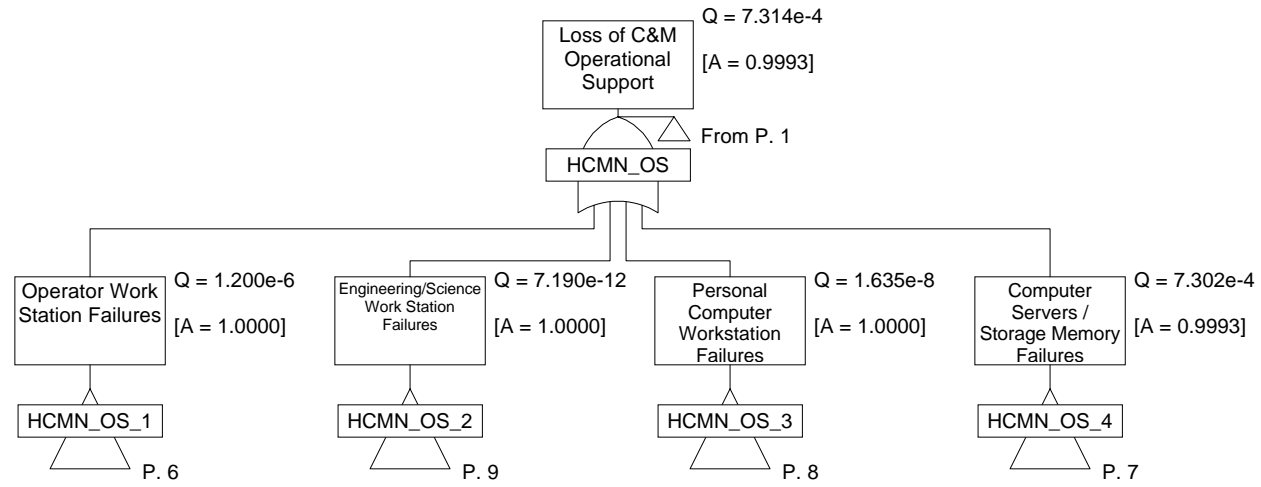

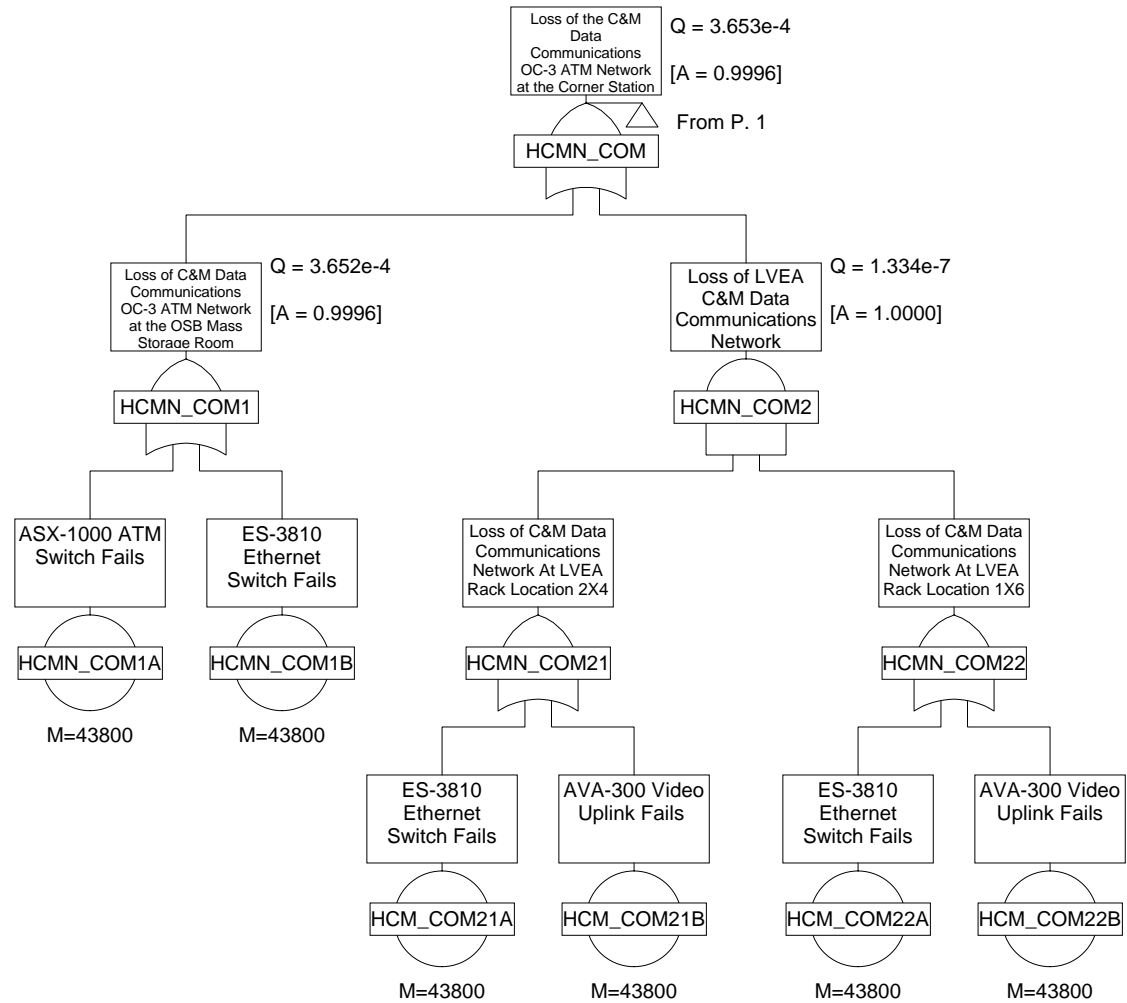

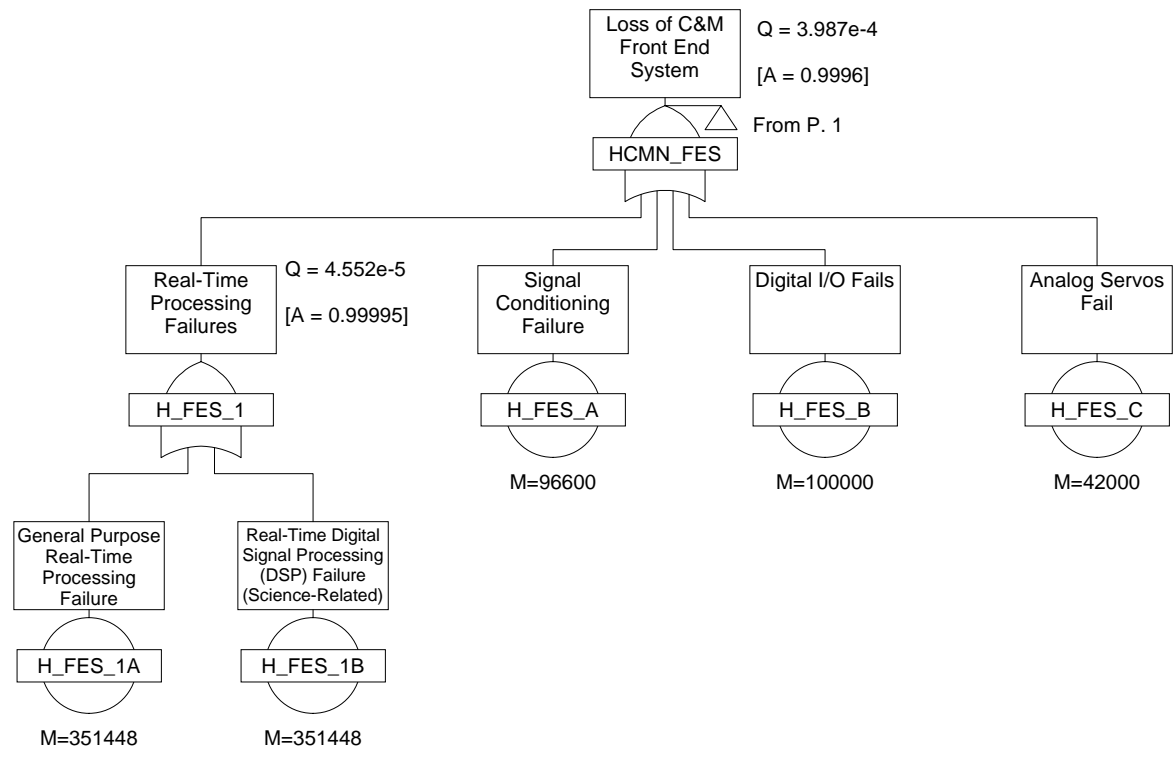

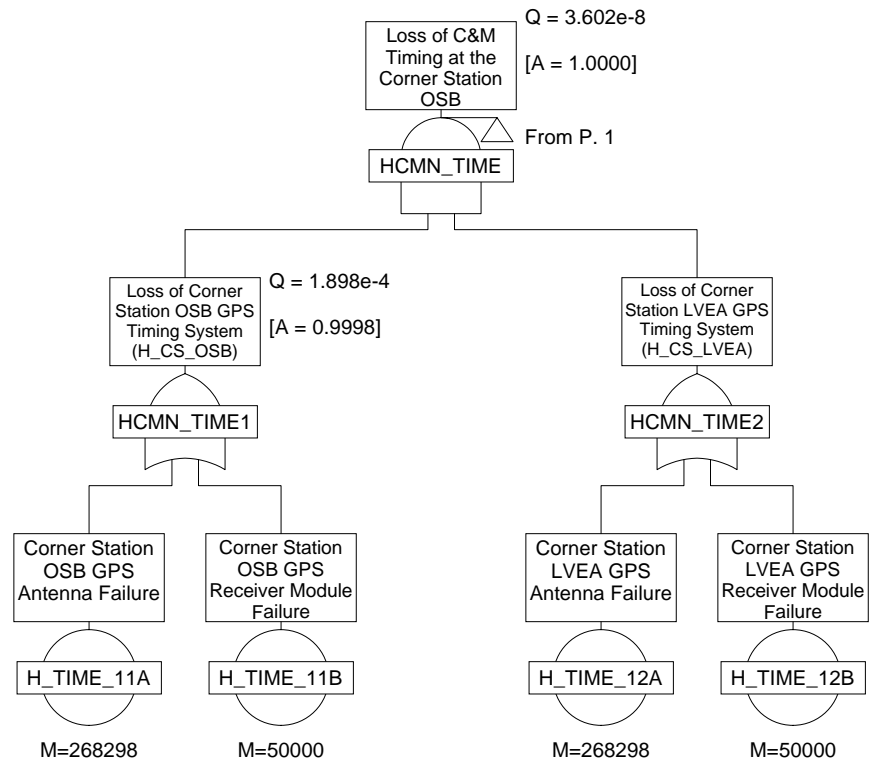

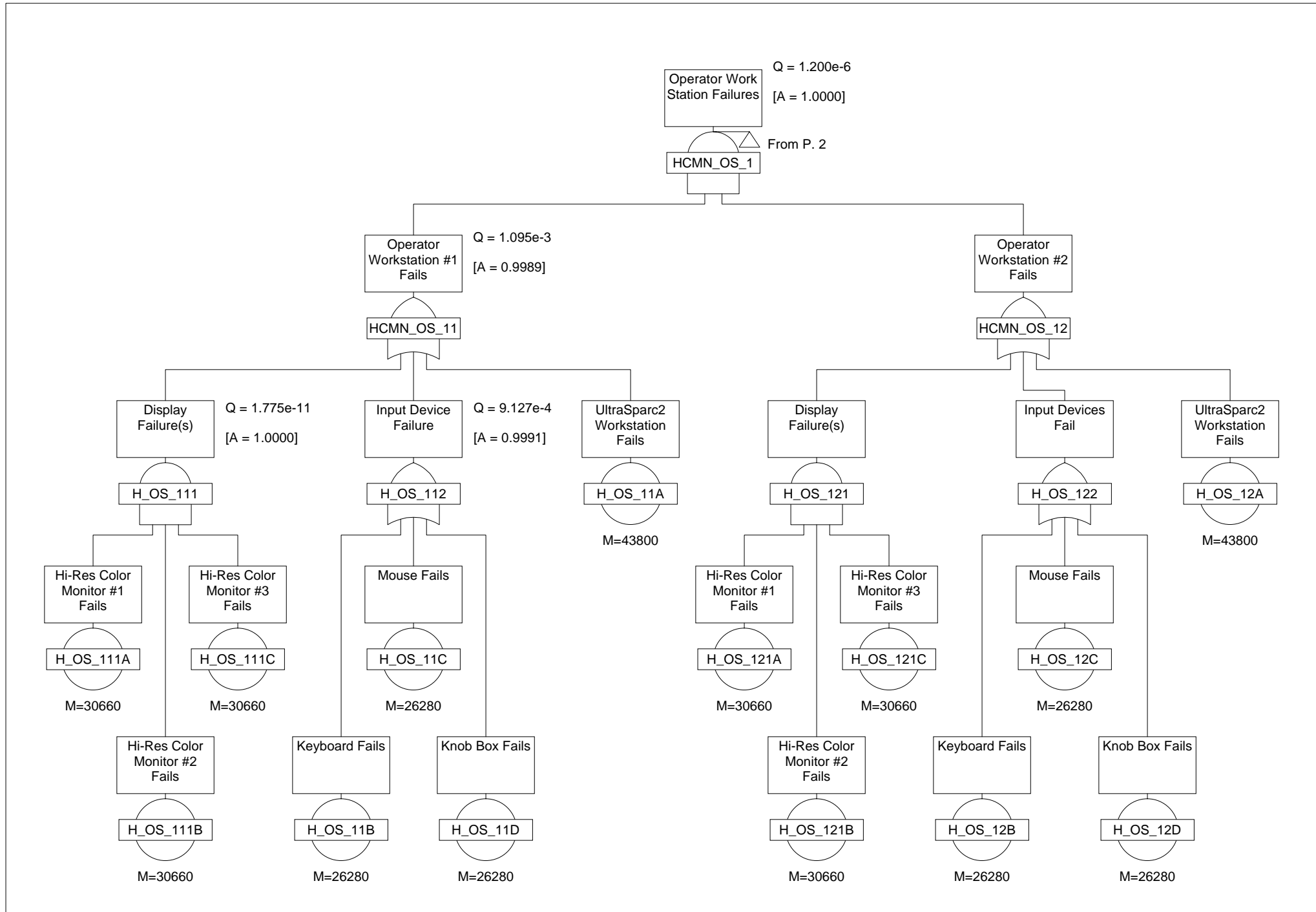

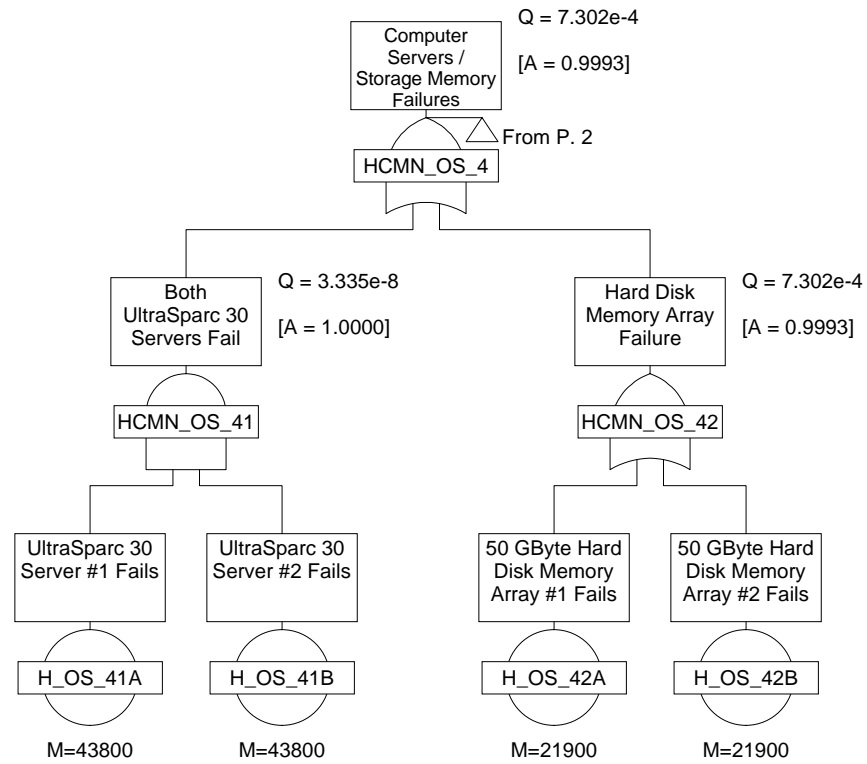

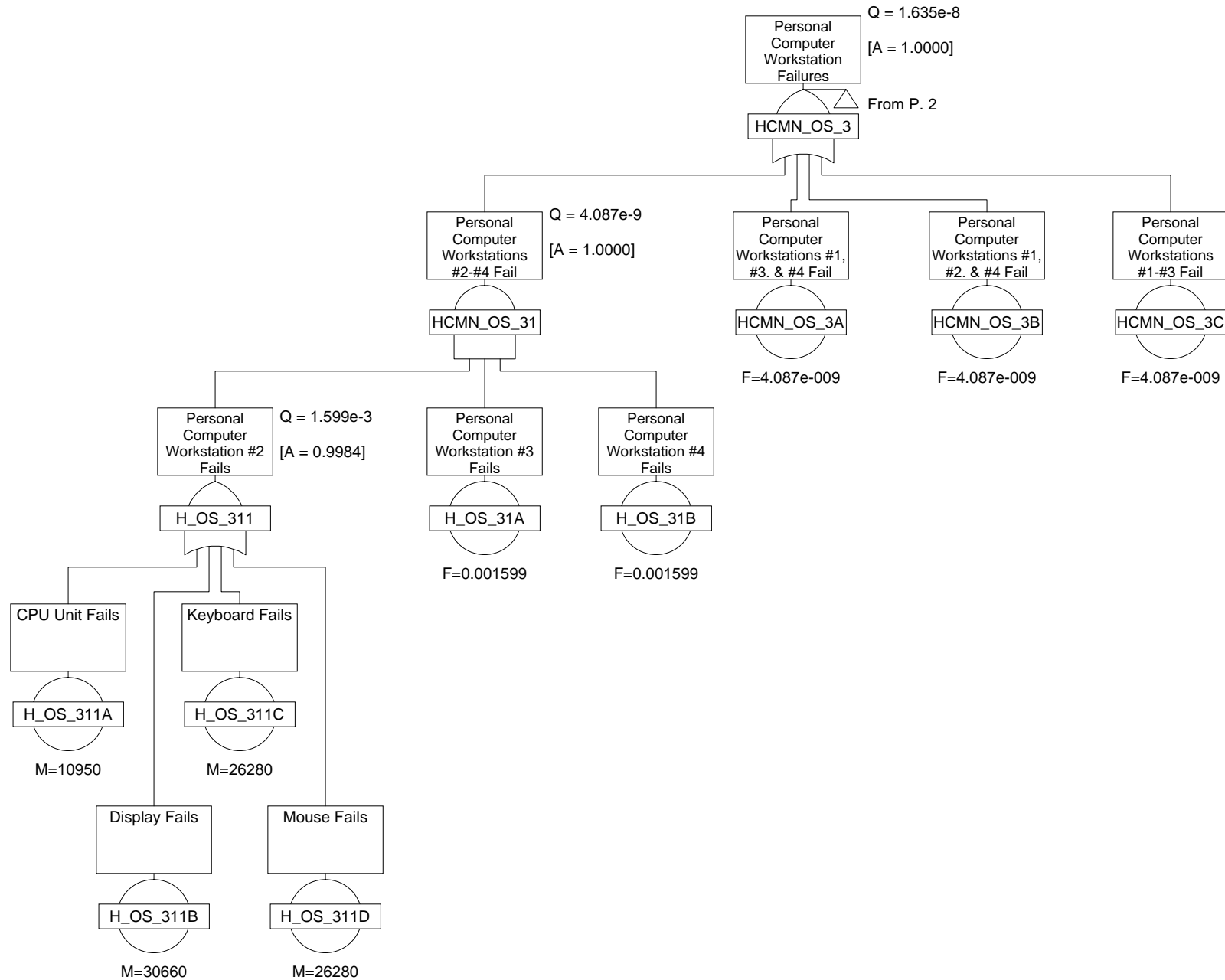

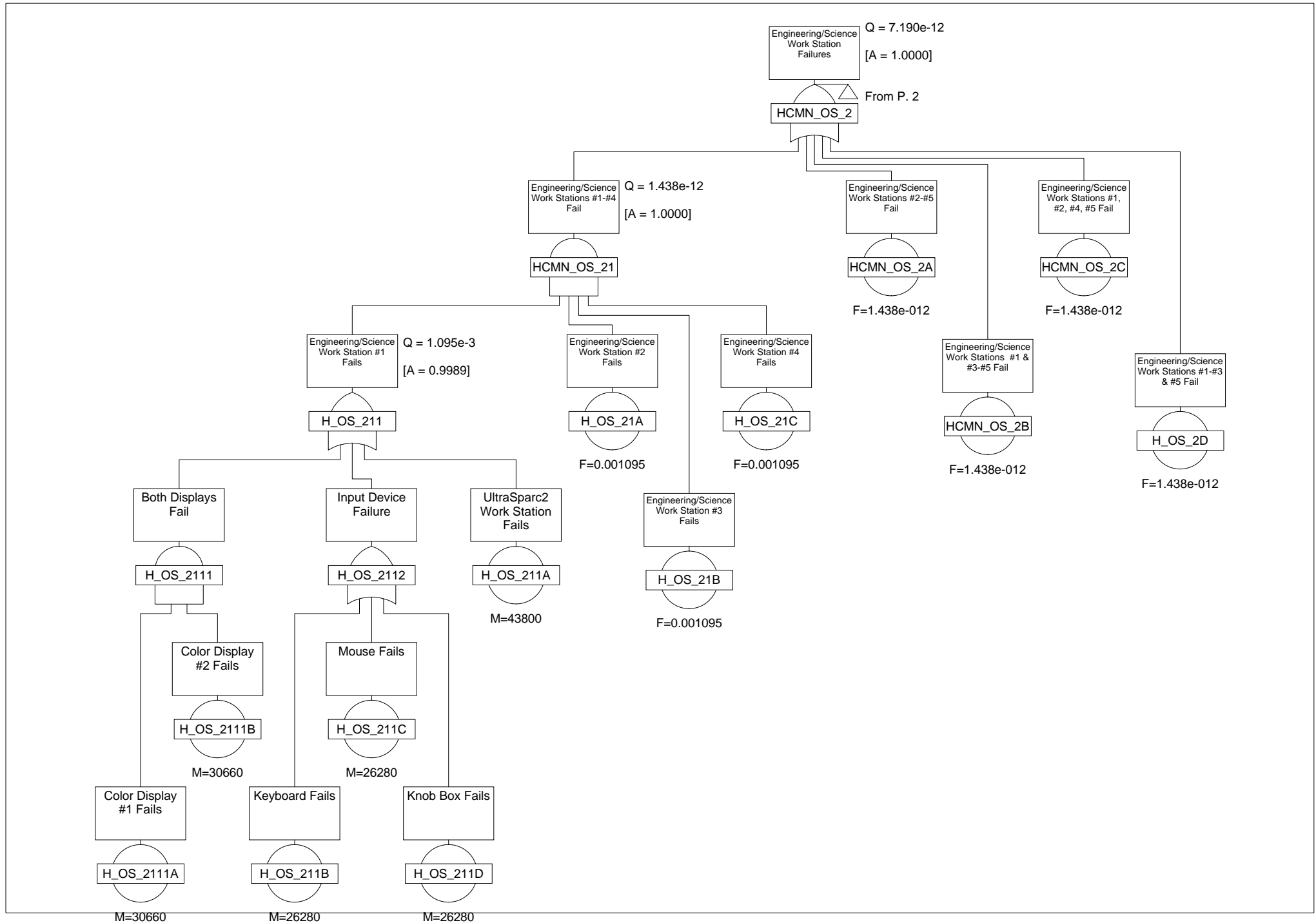

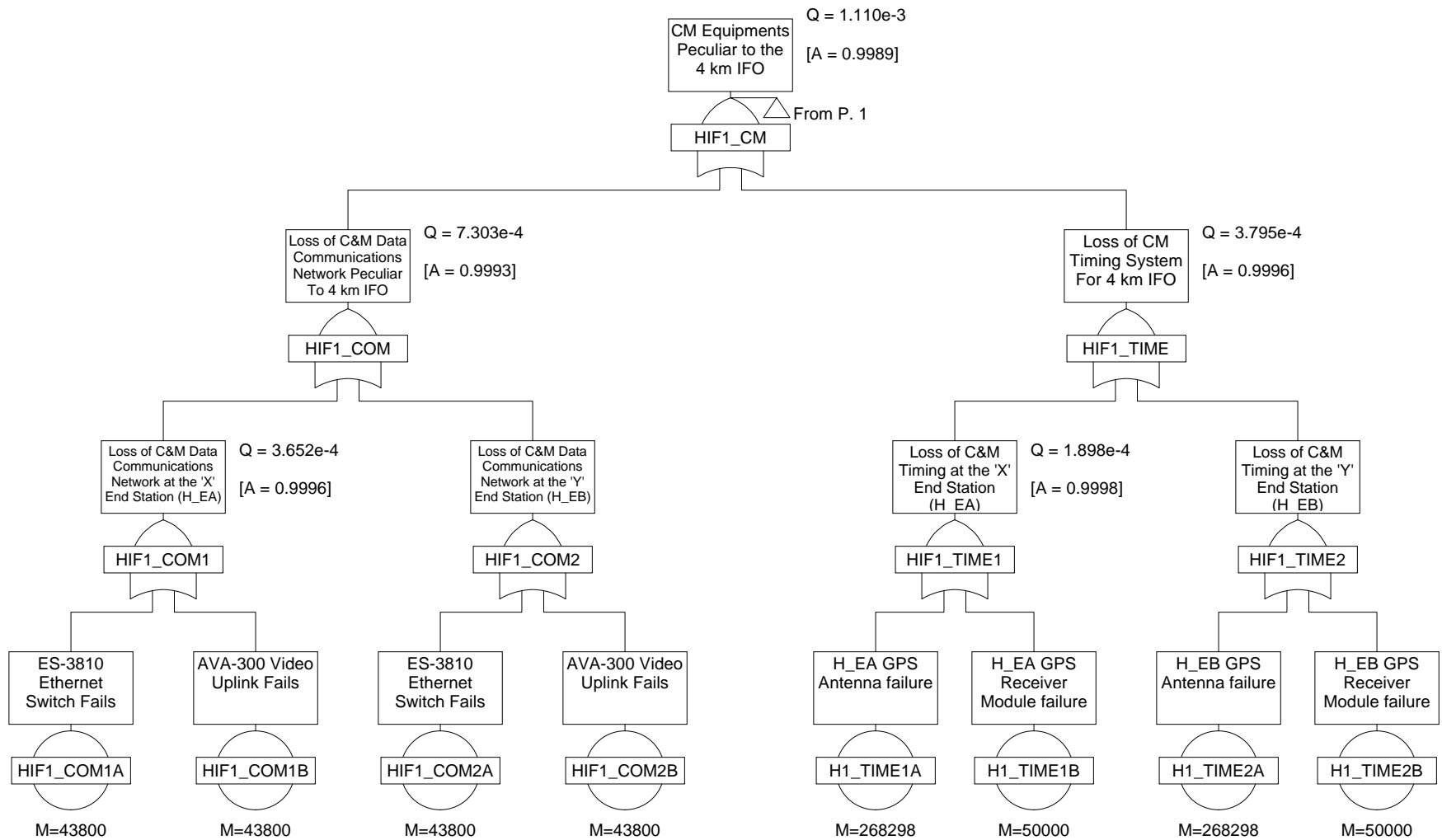

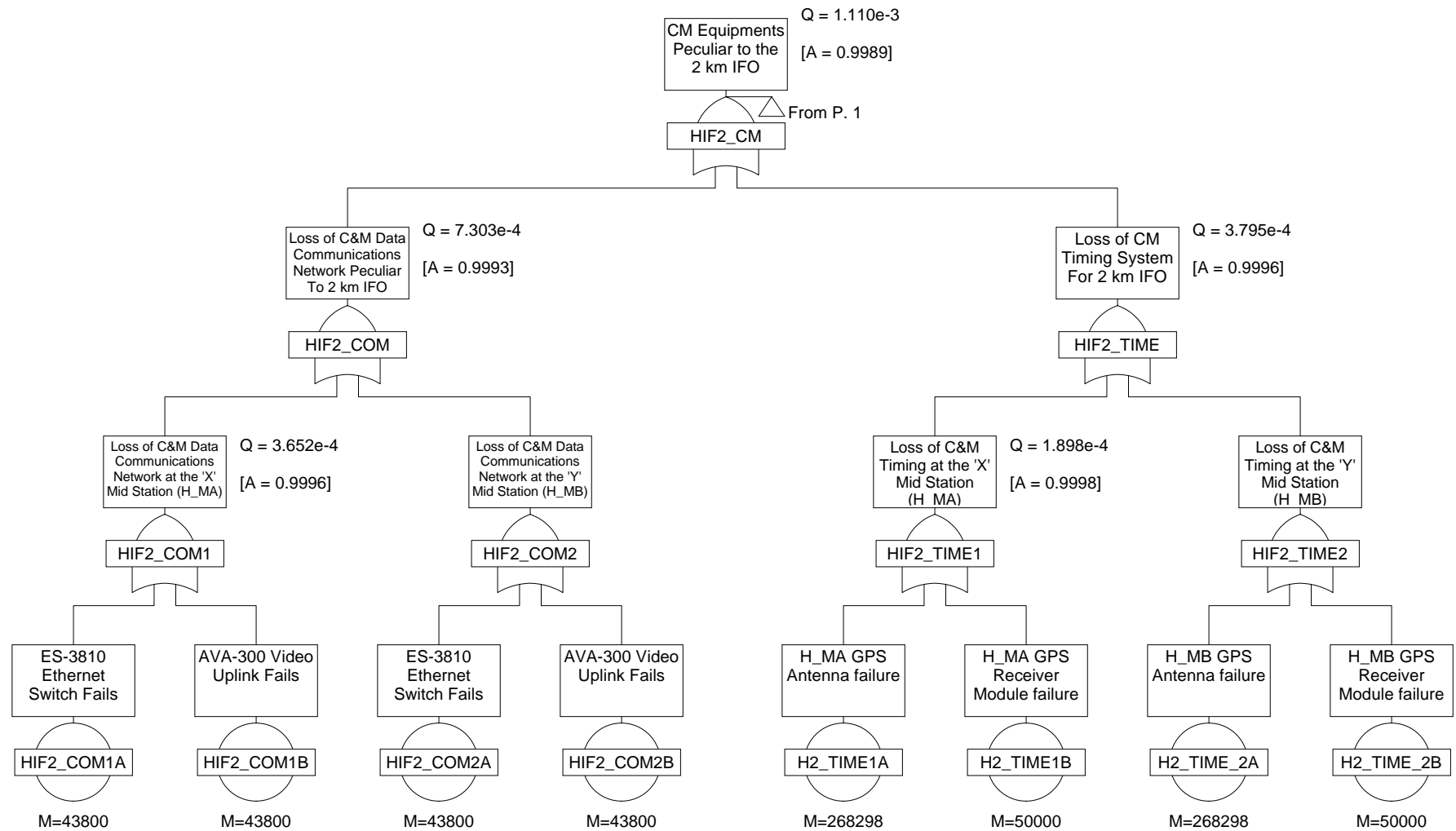

***APPENDIX B:
CM AVAILABILITY PREDICTION,
LIVINGSTON, LA***

NOTES:

1. M = Mean-Time-Between-Failure (MTBF) in hours.
2. F = Fixed Unavailability
3. MDT = Mean-Down-Time = 8.0 hours unless stated otherwise.

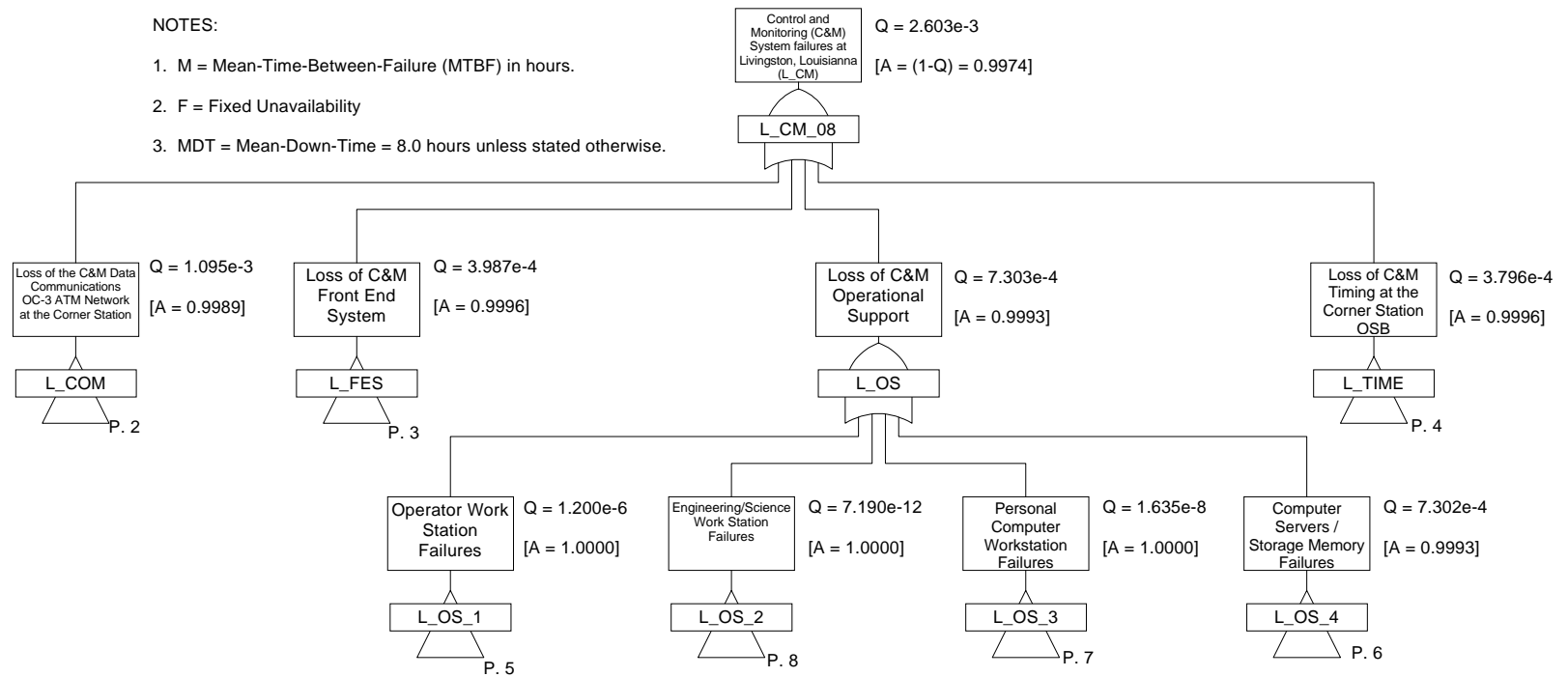

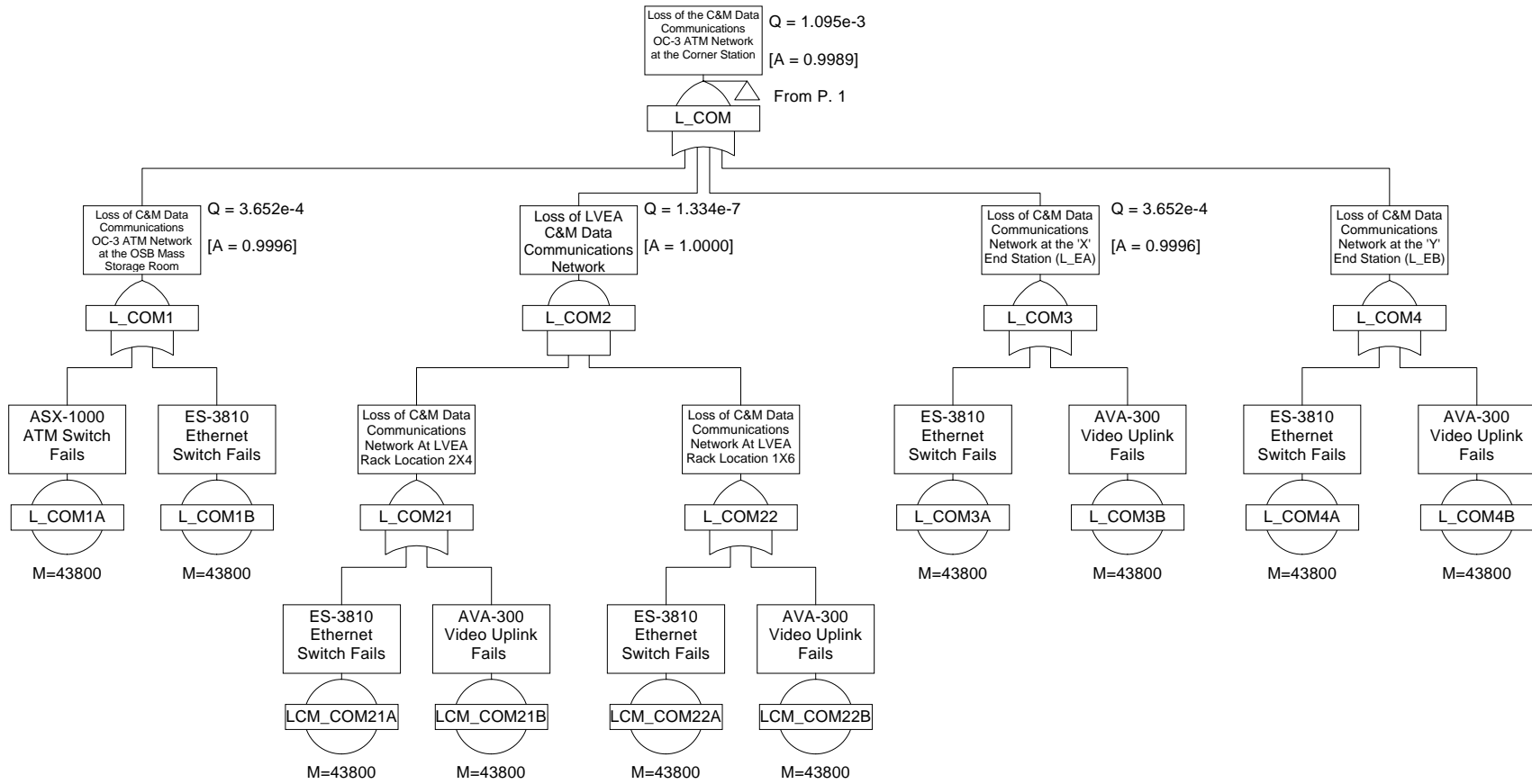

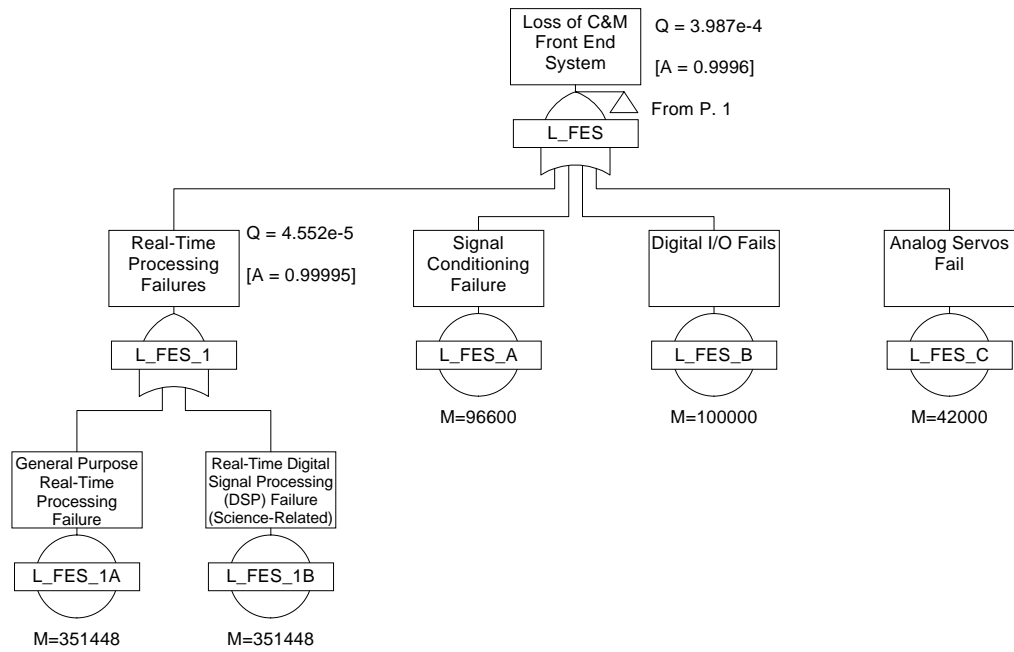

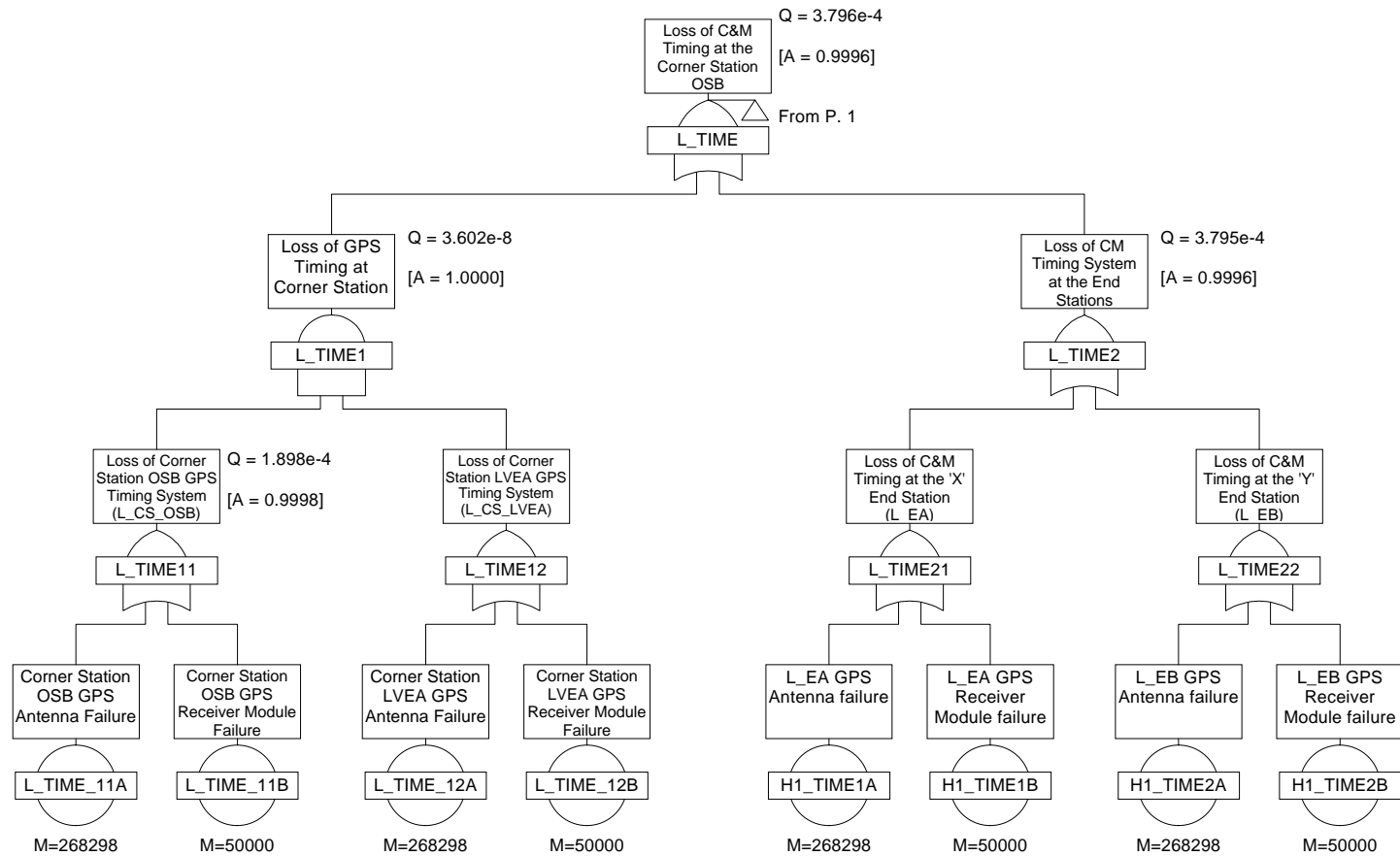

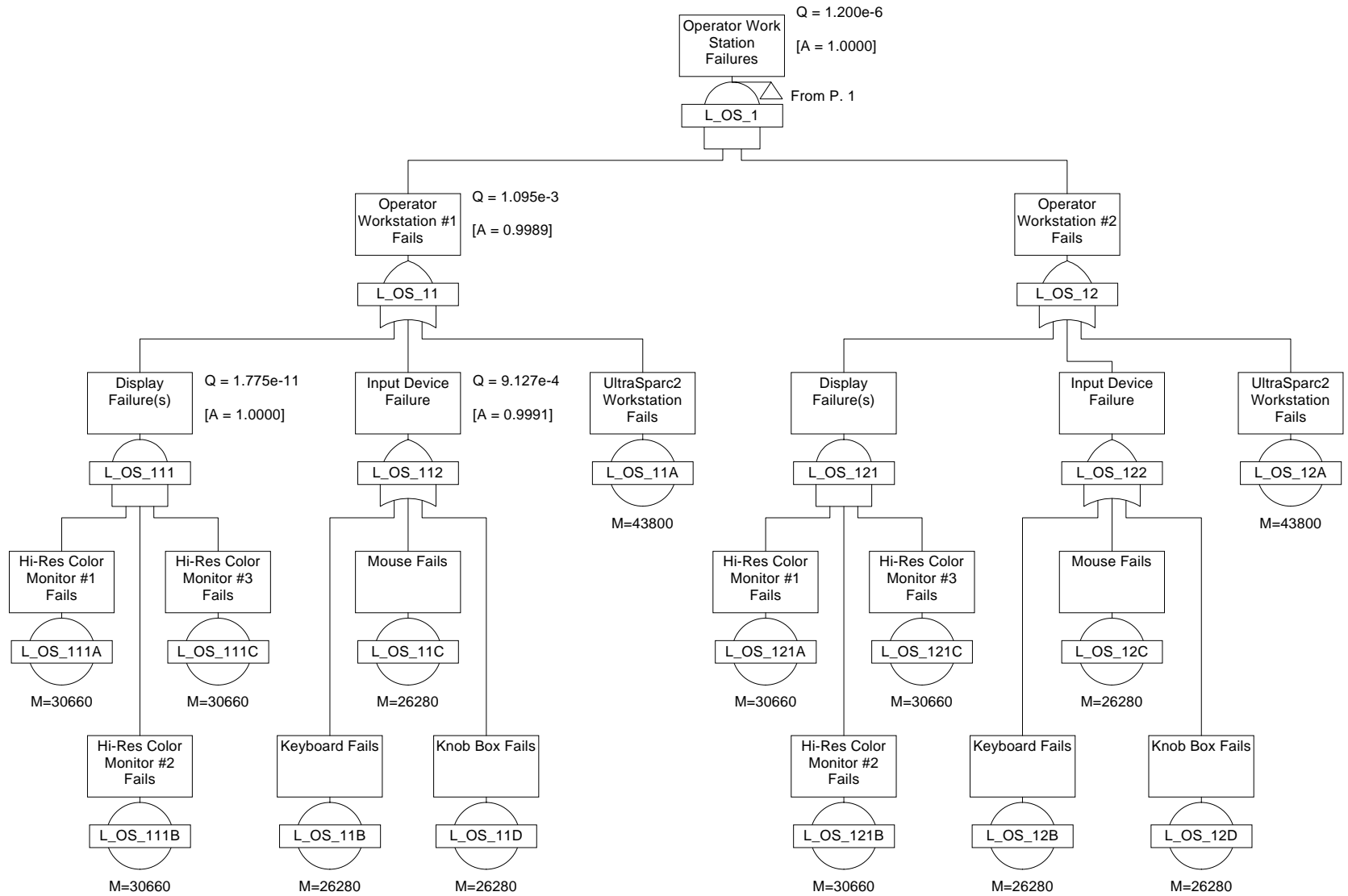

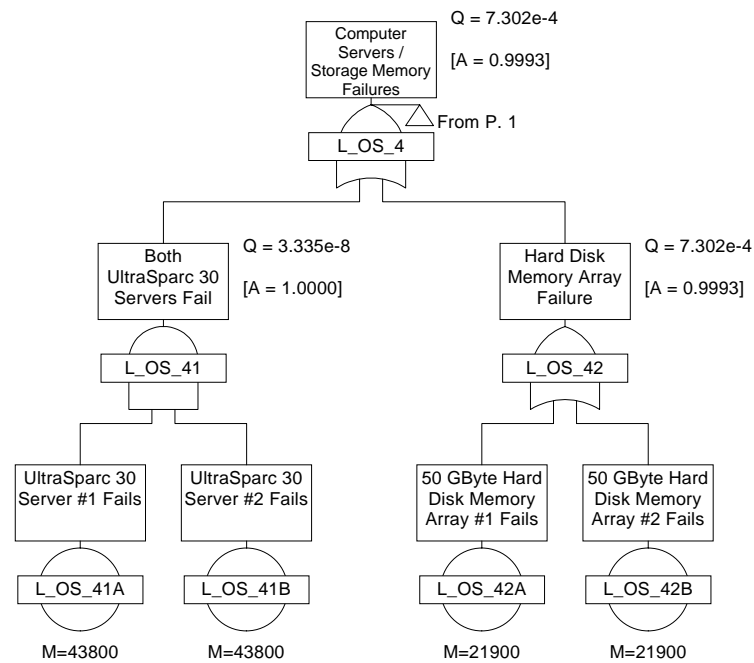

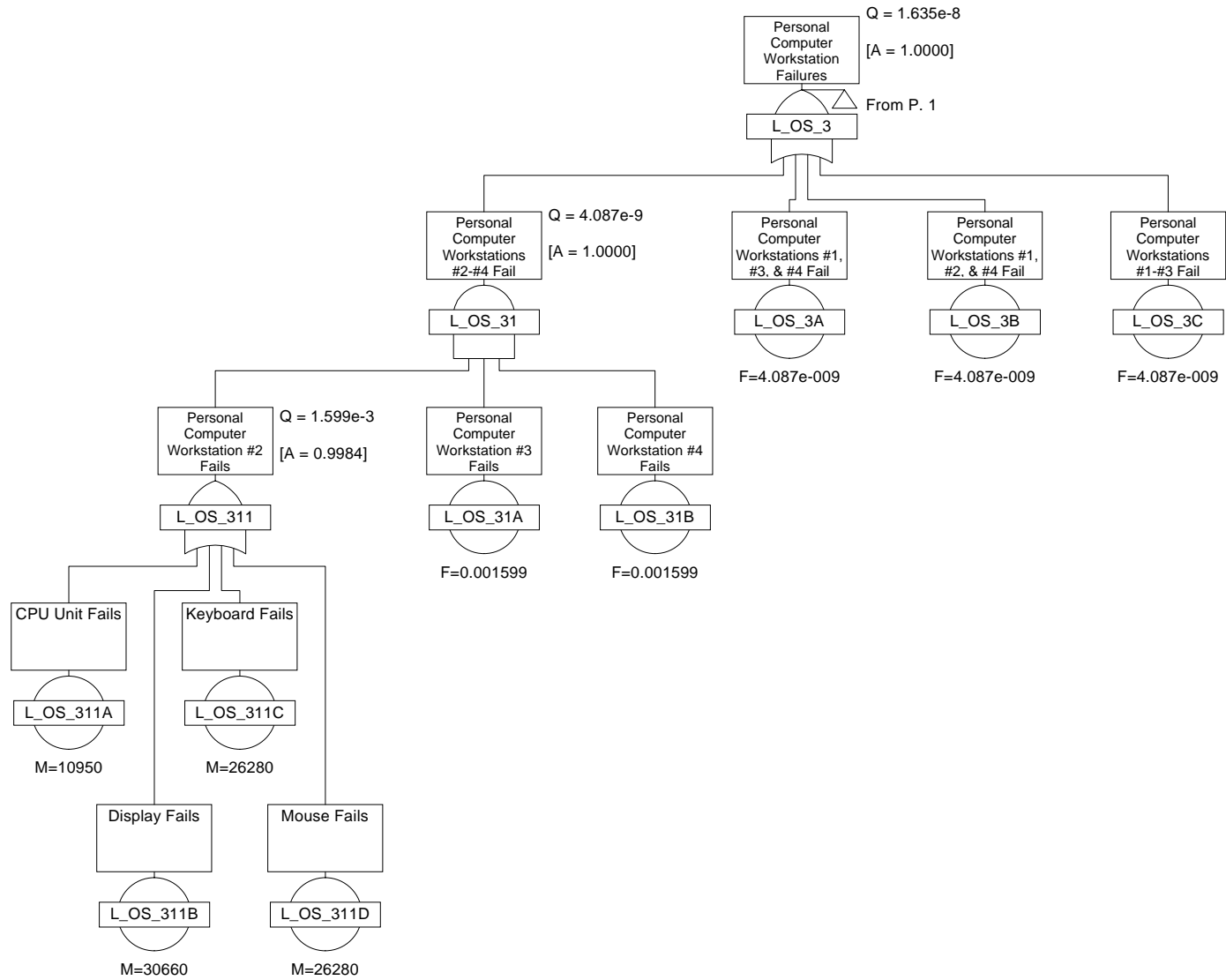

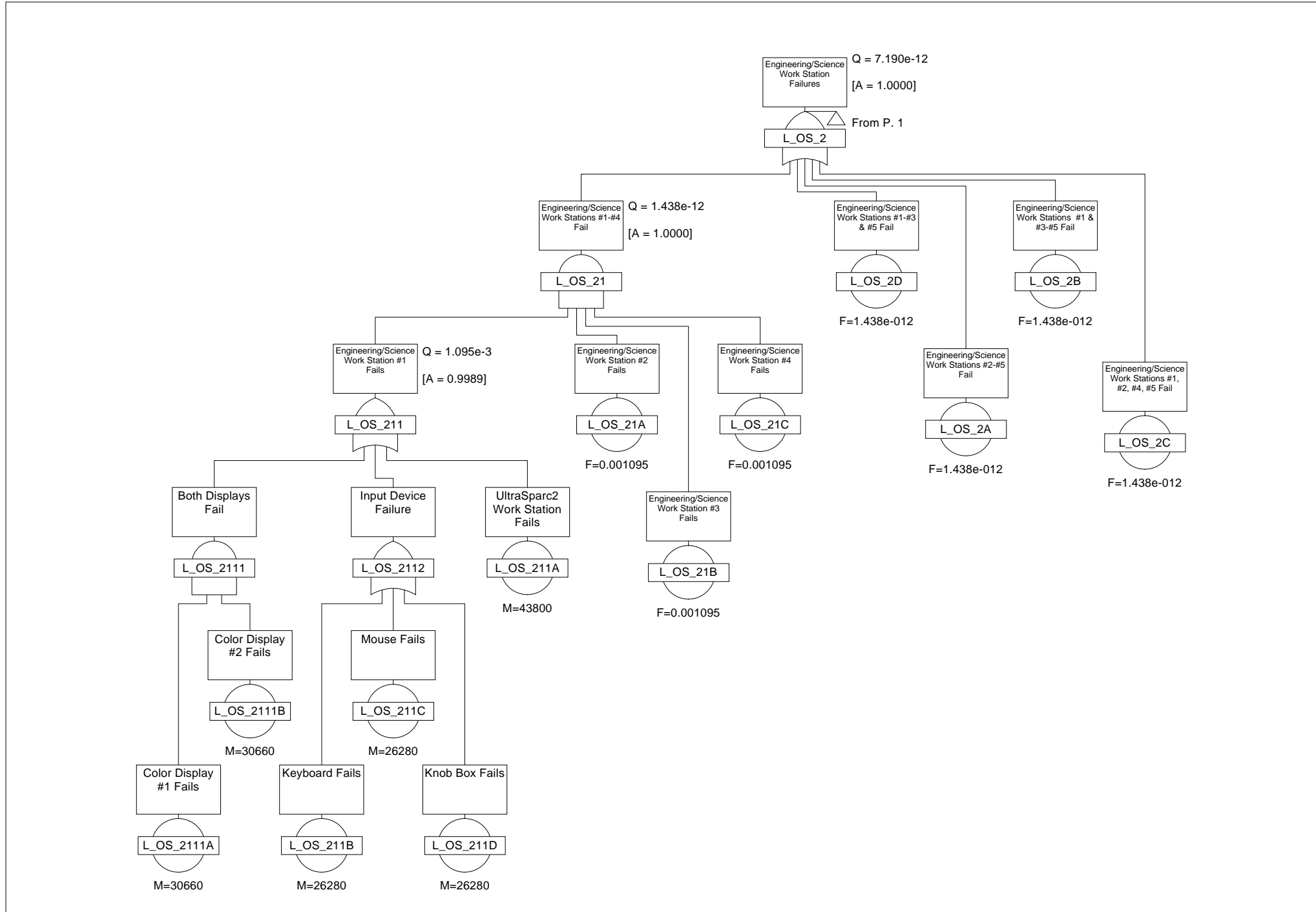

***APPENDIX C:
LIGO 3X
CM AVAILABILITY PREDICTION***

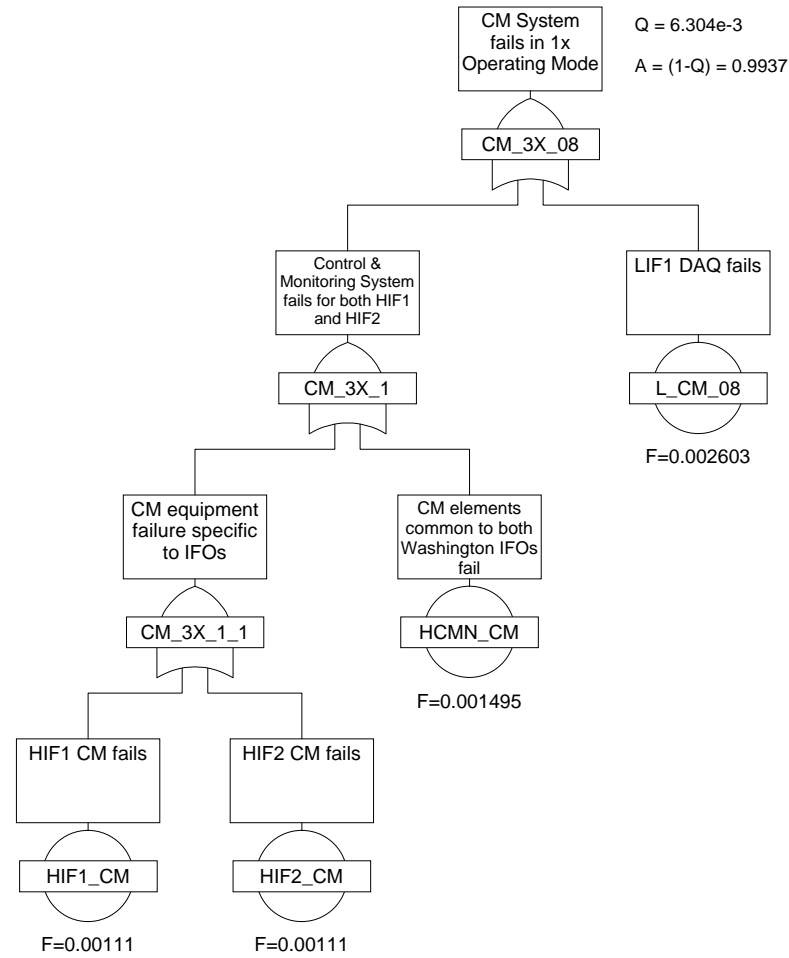

***APPENDIX D:
LIGO 2X
CM AVAILABILITY PREDICTION***

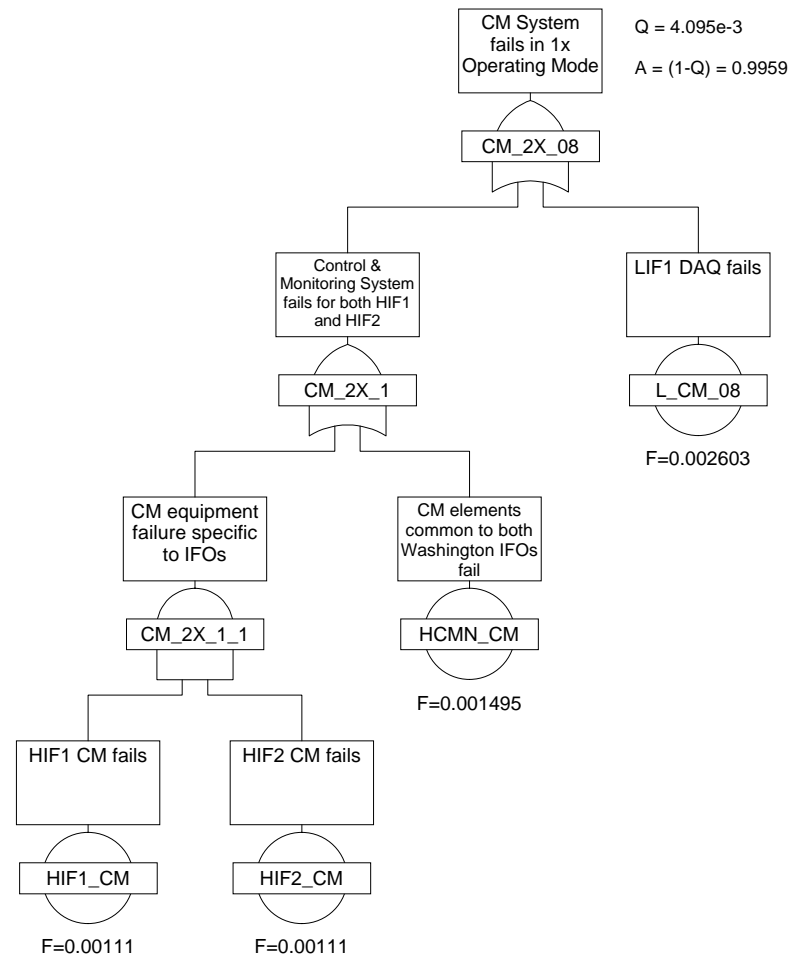

***APPENDIX E:
LIGO 1X
CM AVAILABILITY PREDICTION***

