

New Folder Name Effects of Pockels Cell

Misalignment

EFFECT OF POCKELS CELL MISALIGNMENT

Seiji Kawamura 9-22-90

1) MODEL

A linear model of the effect of Pockels cell (PC) misalignment on the strain signal is shown in the figure in the next page.

The frequency of the light out of the mode cleaner (f_{MC}) is compared with the appropriate resonance frequency of the primary cavity (f_1) to produce the frequency deviation (Δf_1). Δf_1 is fed back to the PC as f_{PC} through the primary servo (A), while the measurable frequency deviation ($\Delta f_1'$) is contaminated with the intensity noise around 12MHz on the primary photodetector, which is related linearly to f_{PC} by B_1 .

The stabilized frequency (f_0) is, this time, compared with the appropriate resonance frequency of the secondary cavity (f_2). The frequency deviation (Δf_2) is contaminated with the intensity noise around 12MHz on the secondary photodetector, which comes from f_{PC} through B_2 .

For simplicity, all quantities are expressed in frequencies in the figure, and PZT path in the primary servo is omitted.

2) ANALYSIS

According to the linear model, the measurable frequency deviation with the secondary cavity ($\Delta f_2'$) is degraded in two ways, one through the residual frequency noise due to B_1 in f_0 , and the other through the intensity noise on the secondary photodetector (f_{B2}).

$$\begin{aligned}\Delta f_2' &= (f_1 - f_2) + (\text{residual frequency noise}) + (\text{intensity caused frequency noise}) \\ &= (f_1 - f_2) + \frac{f_{MC} - f_1}{1 + \left(\frac{A}{1 - AB_1}\right)} + \frac{f_{MC} - f_1}{1 + \left(\frac{A}{1 - AB_1}\right)} \left(\frac{AB_2}{1 - AB_1}\right)\end{aligned}$$

The effect of PC misalignment is significant only when $AB_{1,2} \gg 1$, and at that time,

$$\Delta f_2' = (f_1 - f_2) + \frac{f_{MC} - f_1}{1 - \frac{1}{B_1}} + \frac{f_{MC} - f_1}{1 - \frac{1}{B_1}} \left(-\frac{B_2}{B_1}\right)$$

On the other hand, when $AB_{1,2} \ll 1$, that is, when the effect of PC misalignment is negligible,

$$\Delta f_2' = (f_1 - f_2) + \frac{f_{MC} - f_1}{1 + A}$$

Therefore the effect of the residual frequency noise due to B_1 can be considered to reduce the gain of the primary frequency stabilization A to $(-1/B_1)$. And the effect of the intensity noise on the secondary photodetector is just the same except for the coefficient $(-B_2/B_1)$. If $B_1=B_2$, the two effects will cancel out each other, which is, however, unrealistic..

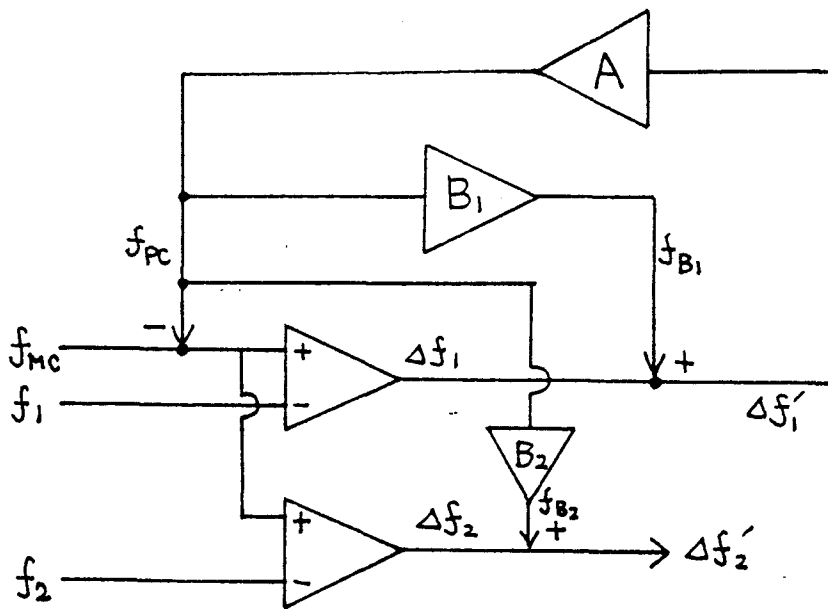

f_{MC} : Frequency of the light out of the mode cleaner

f_1 : Resonance frequency of the primary cavity

f_0 : Stabilized frequency

Δf_1 : True frequency deviation (between f_0 and f_1)

$\Delta f_1'$: Measurable frequency deviation (between f_0 and f_1)

A : Open loop transfer function of the primary servo

f_{PC} : Equivalent correction frequency to the PC

B_1 : Transfer function from PC correction frequency to deviation frequency (in the primary) due to PC misalignment (through intensity noise around 12MHz)

f_{B1} : False frequency deviation due to PC misalignment

f_2 : Resonance frequency of the secondary cavity

Δf_2 : True frequency deviation (between f_0 and f_2)

$\Delta f_2'$: Measurable frequency deviation (between f_0 and f_2)

B_2 : Transfer function from PC correction frequency to deviation frequency (in the secondary) due to PC misalignment

f_{B2} : False frequency deviation due to PC misalignment

LIGO PROJECT

CALIFORNIA INSTITUTE OF TECHNOLOGY

TO Distribution

DATE 11-13-90

FROM Seiji Kawamura

SUBJECT Effect of Pockels cell misalignment on frequency suppression

Abstract

Frequency suppression by the primary cavity servo calculated using linear model agrees well with the measured frequency suppression.

Distribution:

A. Abramovici
R. Drever
Y. Gursel
F. Raab
M. Regehr
R. Spero
R. Vogt
M. Zucker

In the model (Fig. 2) the effect of Pockels cell (PC) misalignment is just regarded as the existence of spurious feedback paths (from PC voltages to demodulation signals).

According to the model, if $f_1, f_2 \ll f_{MC}$

$$\Delta v'_2 = \frac{(D_2 - D_2 G_P X_1 + D_1 D_2 G_C C + D_1 G_P X_2) f_{MC}}{\{1 - G_P X_1 + D_1 (G_Z Z + G_P P + G_C C)\} (1 + D_2 G_2)}$$

Let's define the frequency suppression by the primary cavity servo G as:

$$\Delta v'_2(\text{with } A1) \equiv \frac{\Delta v'_2(\text{without } A1)}{1 + G}$$

where A1 is the primary cavity servo.

Then we will get:

$$G = \frac{D_1 D_2 (G_Z Z + G_P P) - D_1 G_P X_2}{D_2 + D_1 D_2 G_C C - D_2 G_P X_1 + D_1 G_P X_2}$$

The frequency suppression was calculated by measuring or reasonably guessing each component which composes G in the above equation. The ideal frequency suppression without the spurious paths was also calculated. They are shown with the measured frequency suppression in Fig.1.

The result is as follows:

(1) The effect of the PC misalignment can be treated as the existence of the spurious feedback paths.

(2) The frequency suppression is reduced by the PC misalignment effect.

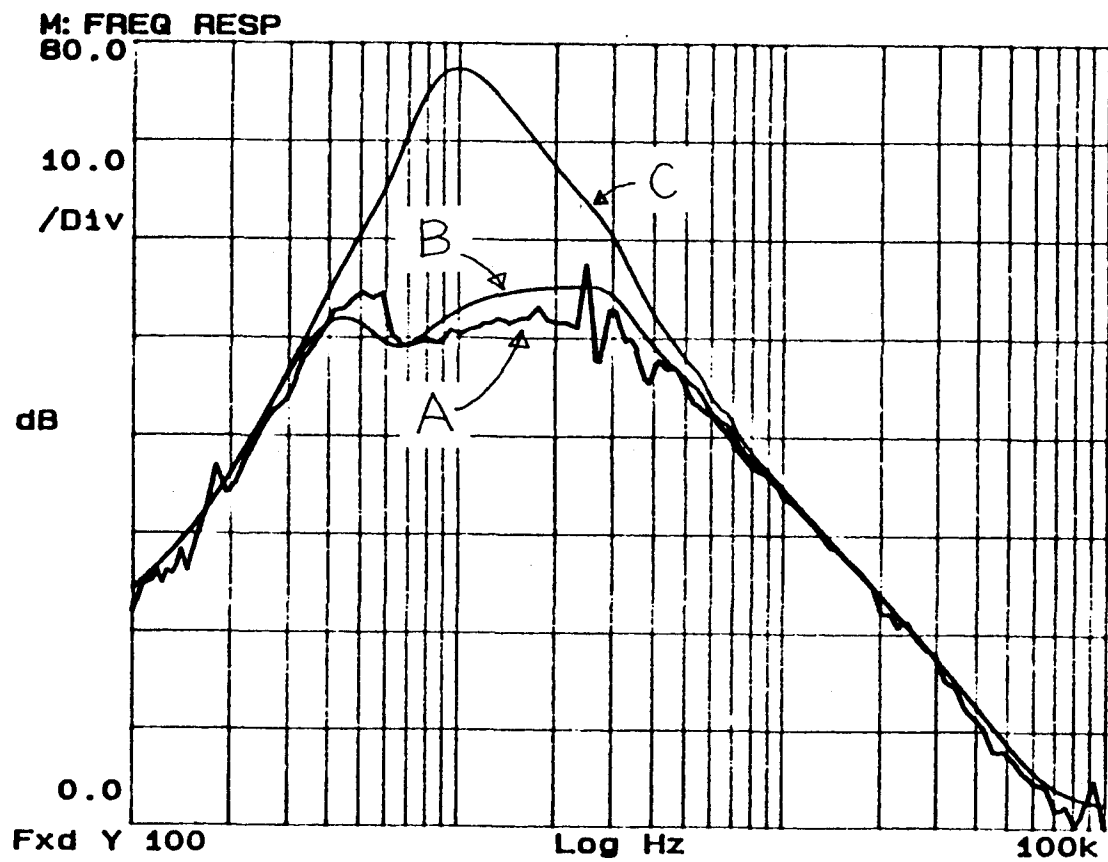

Fig. 1 Frequency suppression of the primary cavity servo.

A: Measured

B: Calculated (with spurious paths)

C: Calculated (without spurious paths)

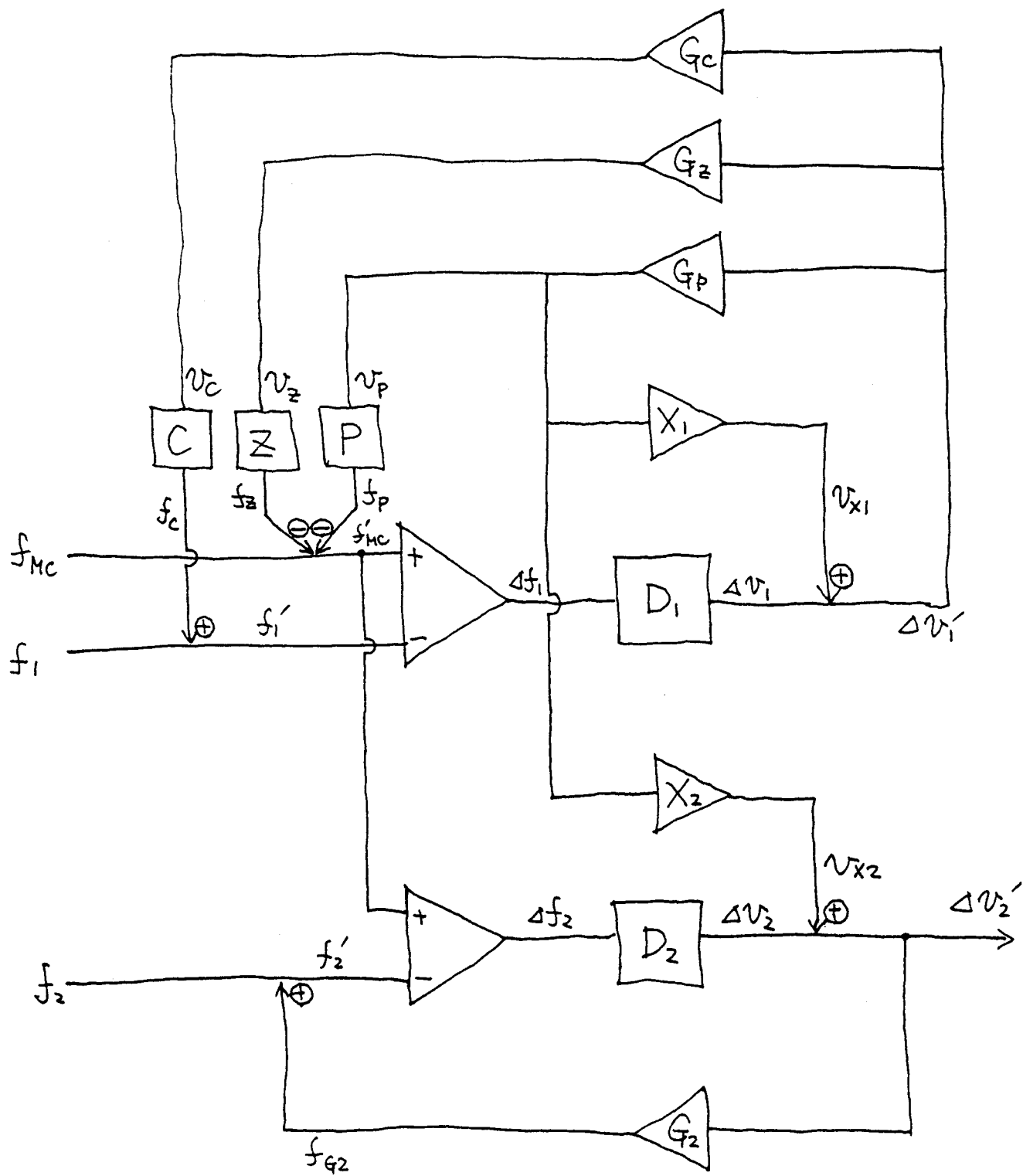

Fig. 2 Linear model of the PC misalignment effect.
 (see next page)

f_{MC} : Frequency of the light out of the mode cleaner

f_1 : Resonance frequency of the primary cavity

f_{MC}' : Stabilized frequency

f_1' : Resonance frequency of the primary cavity (when locked)

Δf_1 : True frequency deviation (between f_{MC}' and f_1')

D_1 : Transfer function from frequency changes to demodulation signal (primary)

Δv_1 : Ideal demodulation signal

$\Delta v_1'$: Measured demodulation signal

G_P : Electronics gain of the PC path

v_P : PC feedback voltages

P : PC conversion factor (from voltages to frequencies)

f_P : Equivalent correction frequency of the PC

G_Z : Electronics gain of the PZT path

v_Z : PZT feedback voltages

Z : PZT conversion factor (from voltages to frequencies)

f_Z : Equivalent correction frequency of the PZT

G_C : Electronics gain of the coil path

v_C : Coil feedback voltages

f_C : Equivalent correction frequency of the coil

X_1 : Transfer function from PC feedback voltages to demodulation signal (primary) due to PC misalignment

v_{X1} : False demodulation signal due to PC misalignment

f_2 : Resonance frequency of the secondary cavity

f_2' : Resonance frequency of the secondary cavity (when locked)

Δf_2 : True frequency deviation (between f_{MC} ' and f_2)

$\Delta f_2'$: Measurable frequency deviation (between f_0 and f_2')

D_2 : Transfer function from frequency changes to demodulation signal (secondary)

Δv_2 : Ideal demodulation signal

$\Delta v_2'$: Measured demodulation signal

G_2 : gain of the coil path (from demodulation signals to frequencies)

f_{G2} : Equivalent correction frequency of the coil (secondary)

X_2 : Transfer function from PC feedback voltages to demodulation signal (secondary) due to PC misalignment

v_{X2} : False demodulation signal due to PC misalignment

BATCH
START

STAPLE
OR
DIVIDER

LIGO PROJECT

CALIFORNIA INSTITUTE OF TECHNOLOGY

TO Distribution

DATE 11-13-90

FROM Seiji Kawamura

SUBJECT Effect of Pockels cell misalignment on frequency suppression

Abstract

Frequency suppression by the primary cavity servo calculated using linear model agrees well with the measured frequency suppression.

Distribution:

- A. Abramovici
- R. Drever
- Y. Gursel
- F. Raab
- M. Regehr
- R. Spero
- R. Vogt
- M. Zucker

In the model (Fig. 2) the effect of Pockels cell (PC) misalignment is just regarded as the existence of spurious feedback paths (from PC voltages to demodulation signals).

According to the model, if $f_1, f_2 \ll f_{MC}$,

$$\Delta v_2' = \frac{(D_2 - D_2 G_P X_1 + D_1 D_2 G_C C + D_1 G_P X_2) f_{MC}}{\{1 - G_P X_1 + D_1 (G_Z Z + G_P P + G_C C)\} (1 + D_2 G_2)}$$

Let's define the frequency suppression by the primary cavity servo G as:

$$\Delta v_2'(with A1) \equiv \frac{\Delta v_2'(without A1)}{1 + G}$$

where A1 is the primary cavity servo.

Then we will get:

$$G = \frac{D_1 D_2 (G_Z Z + G_P P) - D_1 G_P X_2}{D_2 + D_1 D_2 G_C C - D_2 G_P X_1 + D_1 G_P X_2}$$

The frequency suppression was calculated by measuring or reasonably guessing each component which composes G in the above equation. The ideal frequency suppression without the spurious paths was also calculated. They are shown with the measured frequency suppression in Fig.1.

The result is as follows:

- (1) The effect of the PC misalignment can be treated as the existence of the spurious feedback paths.
- (2) The frequency suppression is reduced by the PC misalignment effect.

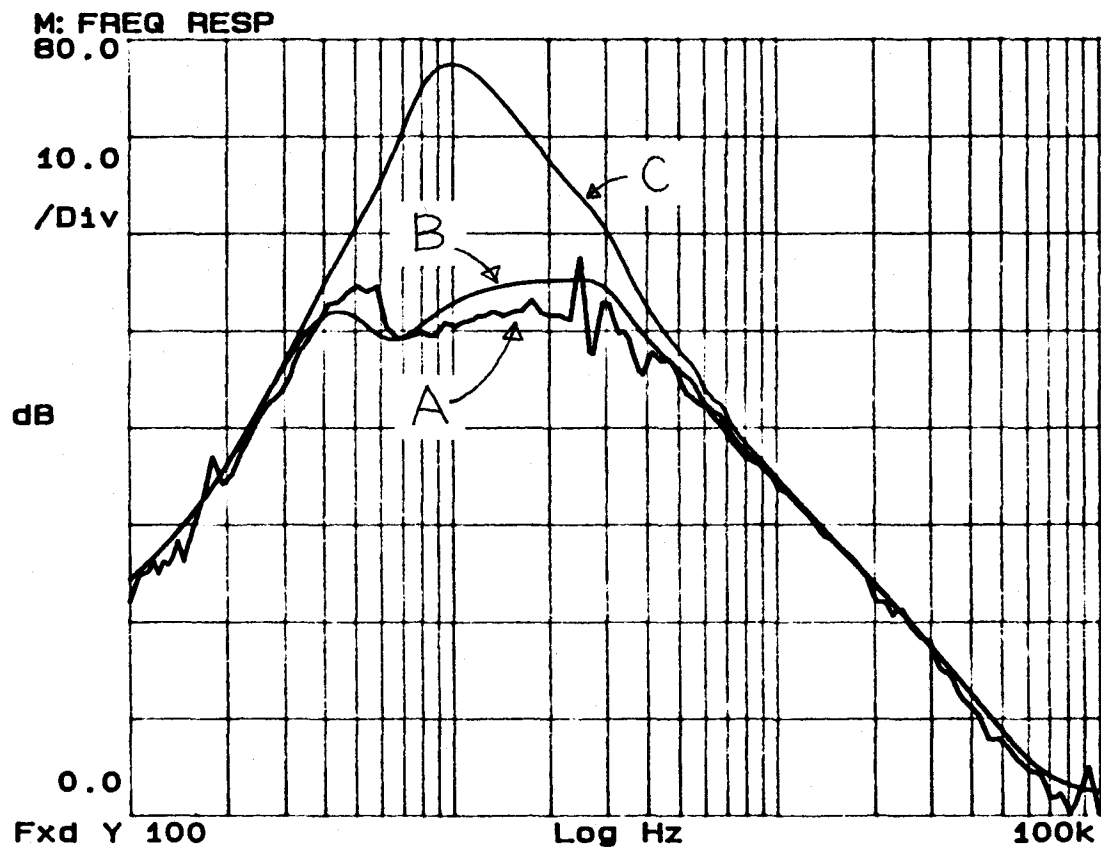

Fig. 1 Frequency suppression of the primary cavity servo.

A: Measured

B: Calculated (with spurious paths)

C: Calculated (without spurious paths)

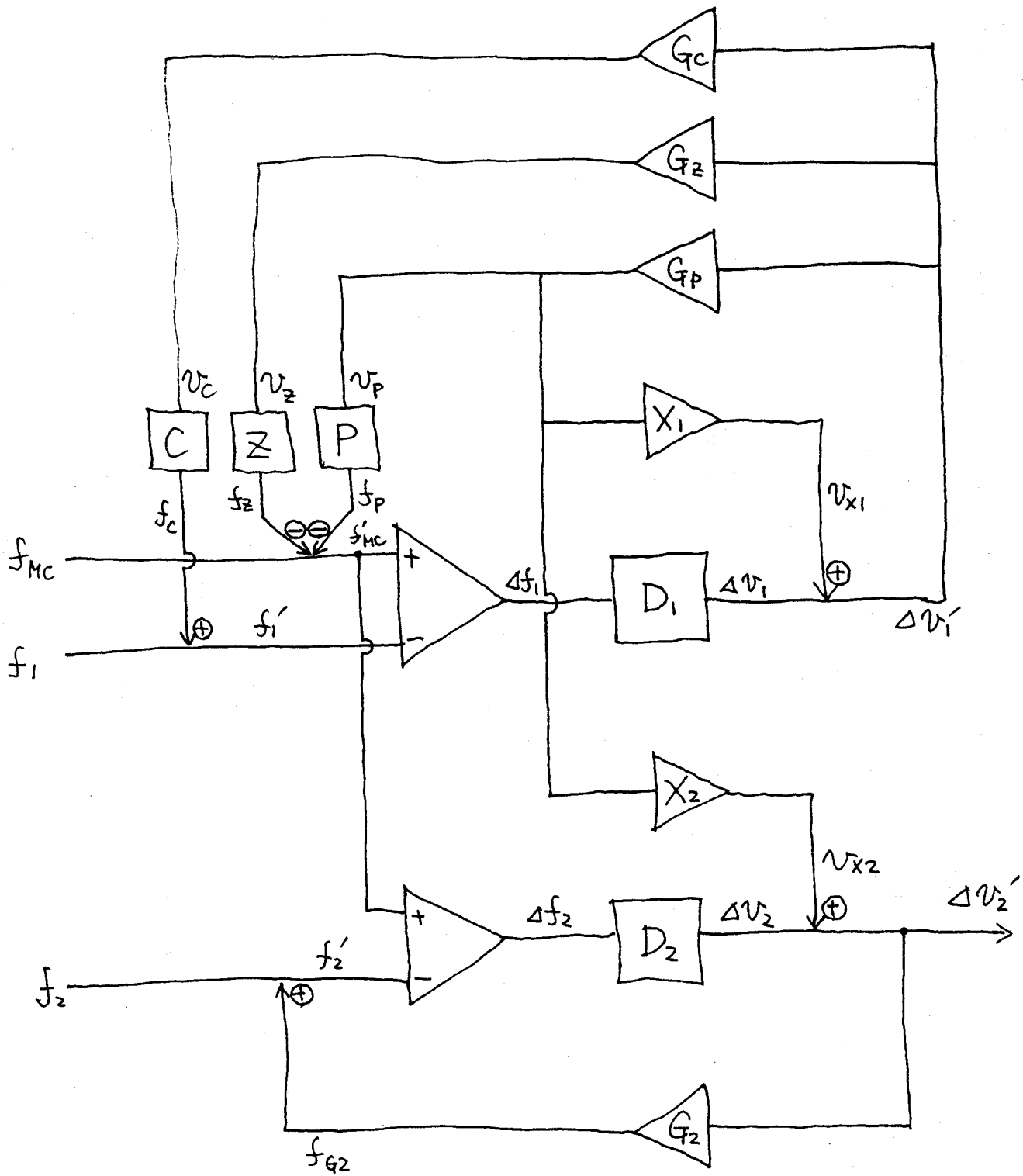

Fig. 2 Linear model of the PC misalignment effect.
 (see next page)

- f_{MC} : Frequency of the light out of the mode cleaner
- f_1 : Resonance frequency of the primary cavity
- f_{MC}' : Stabilized frequency
- f_1' : Resonance frequency of the primary cavity (when locked)
- Δf_1 : True frequency deviation (between f_{MC}' and f_1')
- D_1 : Transfer function from frequency changes to demodulation signal (primary)
- Δv_1 : Ideal demodulation signal
- $\Delta v_1'$: Measured demodulation signal
- G_p : Electronics gain of the PC path
- v_p : PC feedback voltages
- P : PC conversion factor (from voltages to frequencies)
- f_p : Equivalent correction frequency of the PC
- G_Z : Electronics gain of the PZT path
- v_Z : PZT feedback voltages
- Z : PZT conversion factor (from voltages to frequencies)
- f_Z : Equivalent correction frequency of the PZT
- G_C : Electronics gain of the coil path
- v_C : Coil feedback voltages
- f_C : Equivalent correction frequency of the coil
- X_1 : Transfer function from PC feedback voltages to demodulation signal (primary) due to PC misalignment
- v_{X1} : False demodulation signal due to PC misalignment
- f_2 : Resonance frequency of the secondary cavity
- f_2' : Resonance frequency of the secondary cavity (when locked)

Δf_2 : True frequency deviation (between f_{MC} ' and f_2)

$\Delta f_2'$: Measurable frequency deviation (between f_0 and f_2')

D_2 : Transfer function from frequency changes to demodulation signal (secondary)

Δv_2 : Ideal demodulation signal

$\Delta v_2'$: Measured demodulation signal

G_2 : gain of the coil path (from demodulation signals to frequencies)

f_{G2} : Equivalent correction frequency of the coil (secondary)

X_2 : Transfer function from PC feedback voltages to demodulation signal (secondary) due to PC misalignment

v_{X2} : False demodulation signal due to PC misalignment