

REV.	DATE	DCN #	DRAWING TREE #
v2	29 DEC 2012	E1000360	-
v3	28 MAY 2013	E1000360-v6	-
v4	22 JUL 2013	-	-

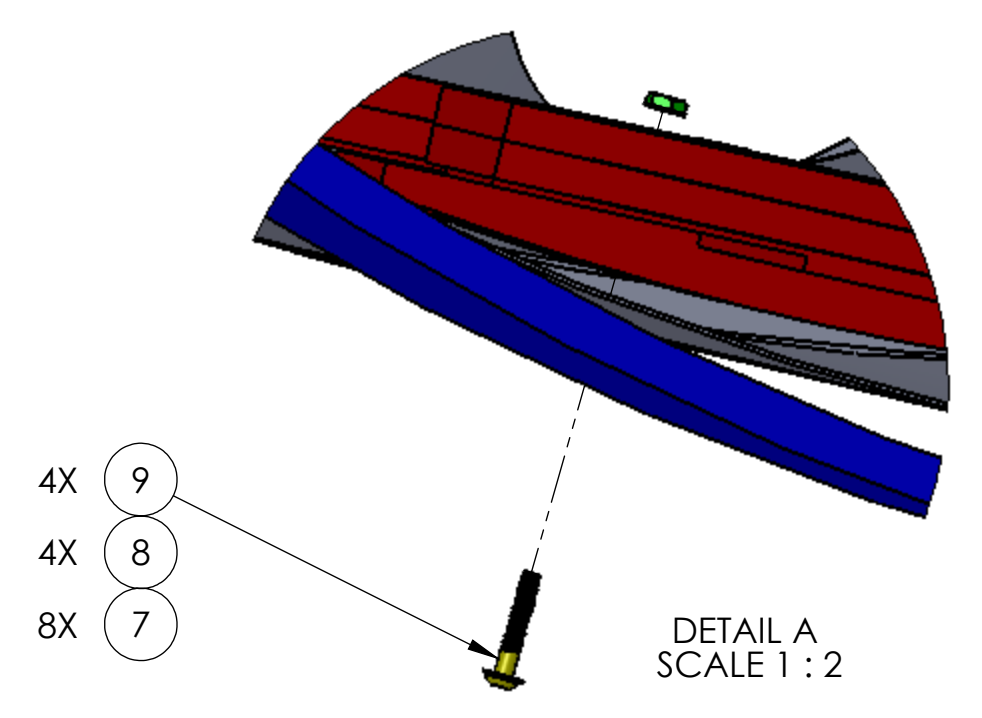
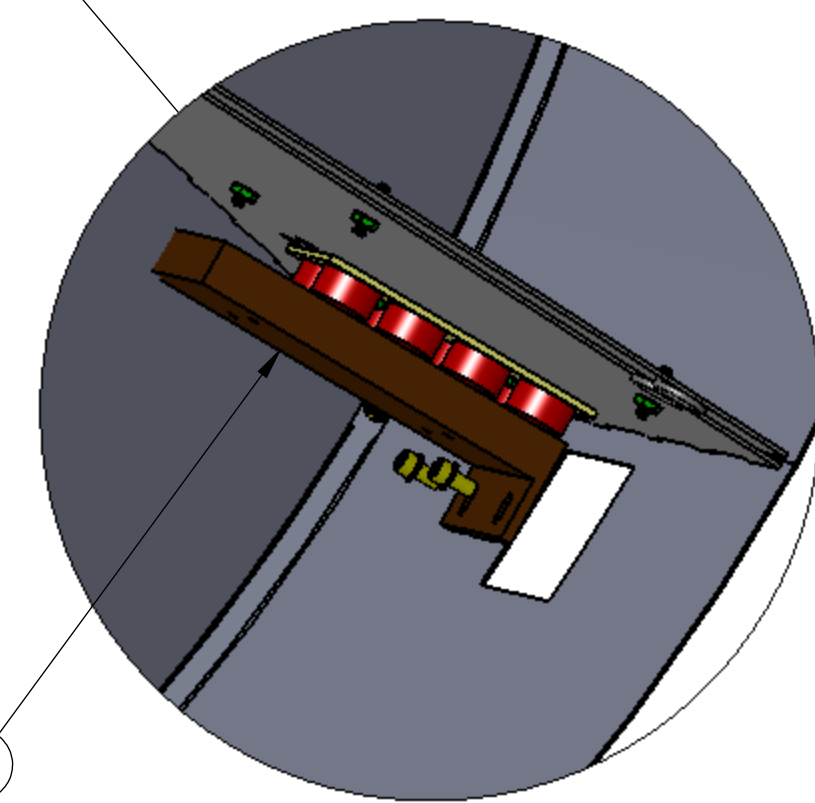
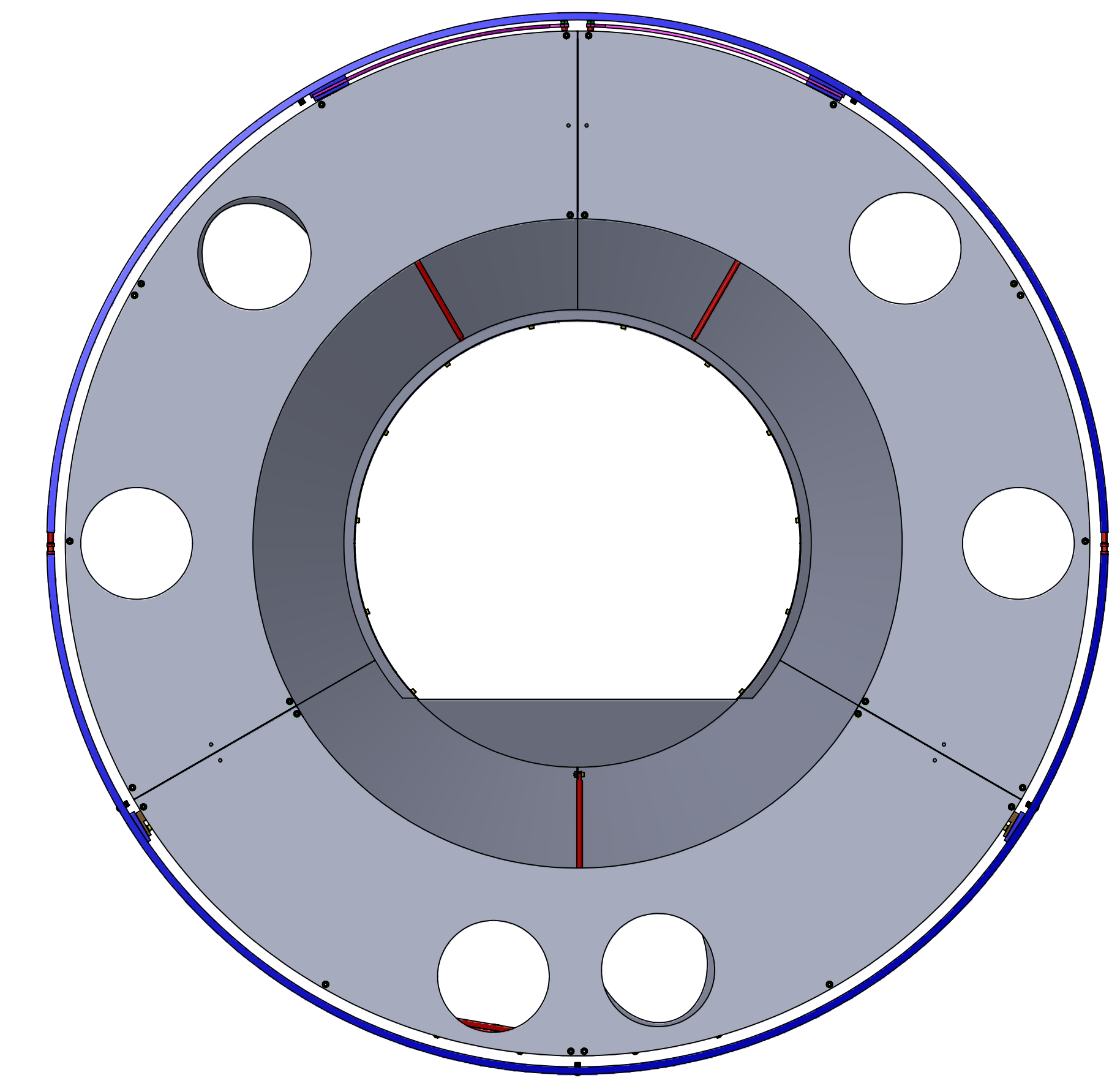
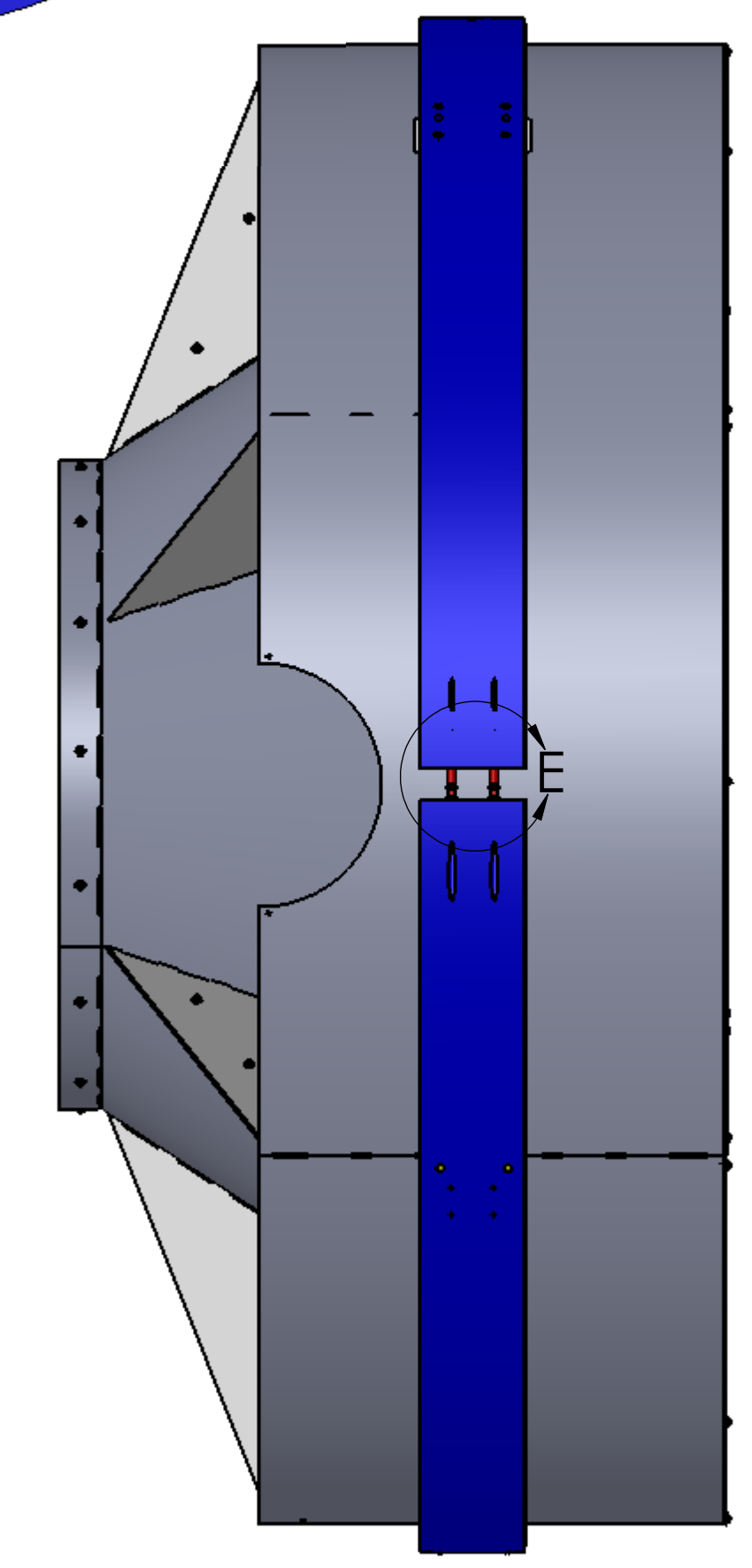
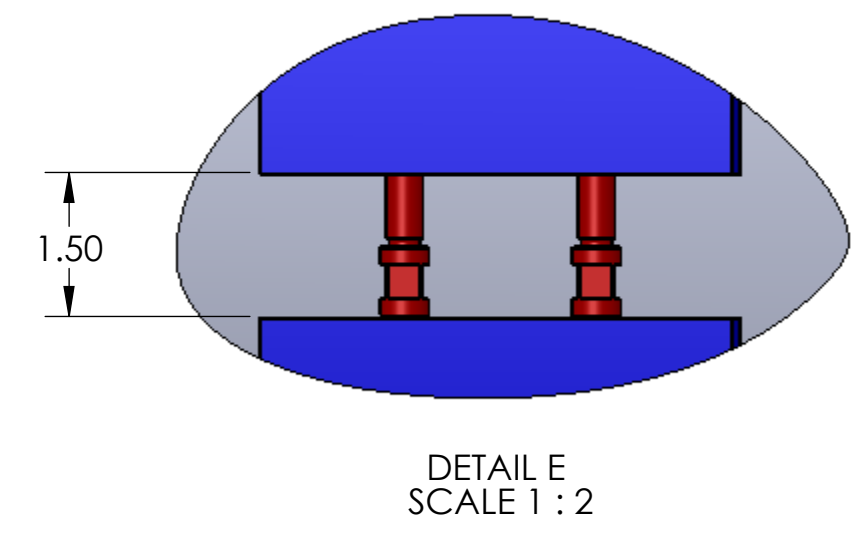
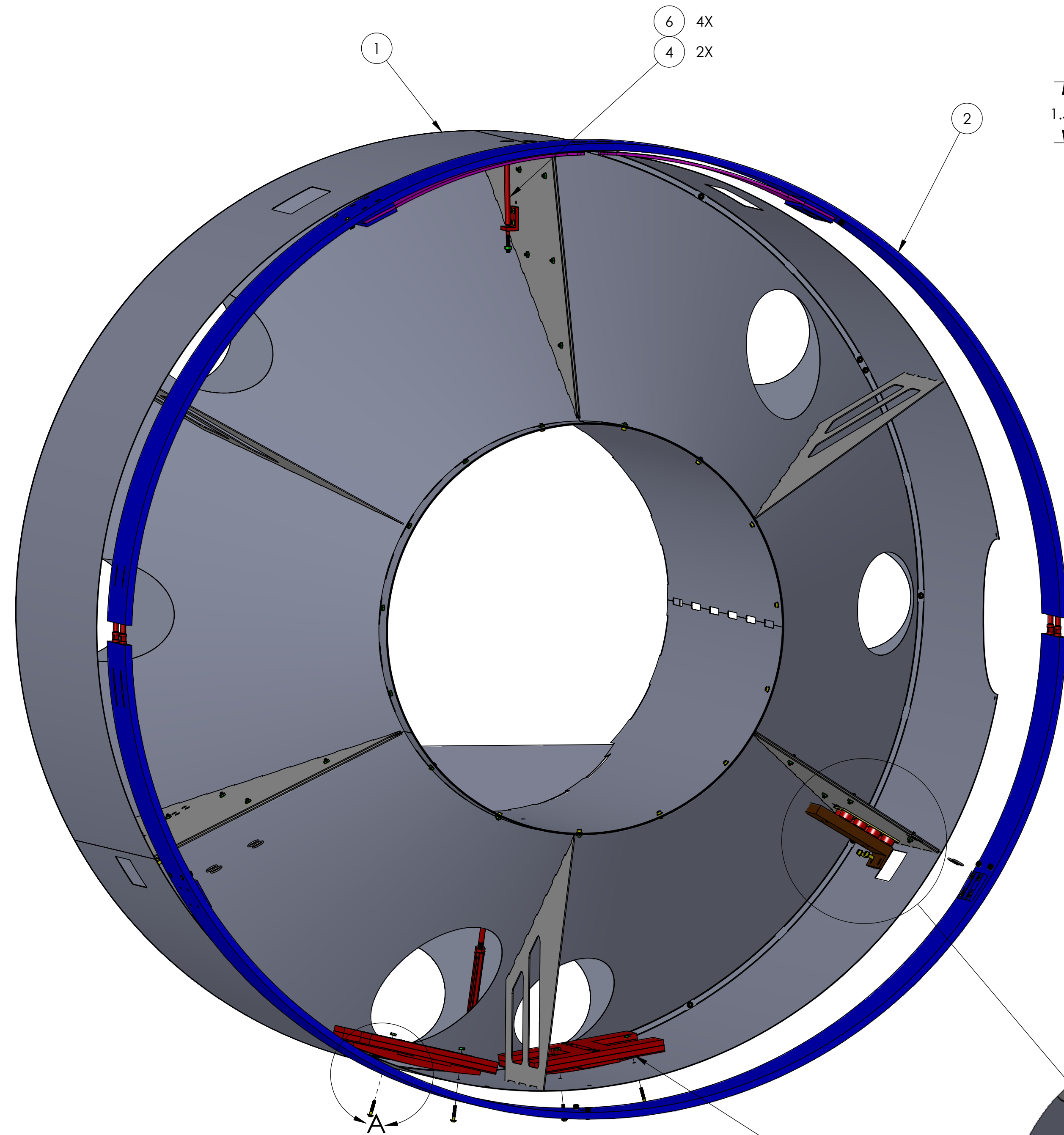

ITEM NO.	PART NUMBER	DESCRIPTION	MATERIAL	QTY	SPARE	TOTAL
12	V1156 2-116	VITON O-RING	VITON	8	0	0
11	C-2008-N	SOCKET HEAD CAP SCREW, SHC, 1/4-20 x 1/2" L	18-8 SSTL	4	0	0
10	WF-25	FLAT WASHER 1/4 SCREW SIZE	18-8 SSTL	4	0	0
9	BU-1016-N	BUTTON HEAD SOCKET CAP SCREW, #10-32 x 1" L	18-8 SSTL	4	0	0
8	N-1032-A	HEX NUT, 10-32 THRD SIZE	Ag-PLATED 300 SSTL	4	0	0
7	91241A011	FLAT WASHER No. 10 SCREW SIZE	300 SSTL	8	0	0
6	N-2520-A	HEX NUT, 1/4-20 THRD SIZE	Ag-PLATED 300 SSTL	4	0	0
5	D1100821	LOWER COPPER PLATE	COPPER	2	0	0
4	D1001970	SUSPENSION ROD	304, 316 OR 302 SSTL	2	0	0
3	D1002402	BALANCE WEIGHT ASSEMBLY	N/A	2	0	0
2	D1002084	OUTER RING ASSY	N/A	1	0	0
1	D1003227	MANIFOLD-CRYOPUMP BAFFLE RADIAL SEGMENT ASSY, ETM Y	N/A	1	0	0

NOTES AND TOLERANCES: (UNLESS OTHERWISE SPECIFIED)

DIMENSIONS ARE IN INCHES

TOLERANCES:
 .XX ± .06
 .XXX ± .010

ANGULAR ± 1.0°

1. TWO BALANCED WEIGHT ASSEMBLIES (D1002402) TO BE INSTALLED BEFORE ATTACHING BAFFLE TO SUSPENSION RING.

2. TORQUE SHCS TO VALUES SPECIFIED IN LIGO T1100066.

MATERIAL	N/A	FINISH	N/A μinch
----------	-----	--------	-----------

LIGO CALIFORNIA INSTITUTE OF TECHNOLOGY
 MASSACHUSETTS INSTITUTE OF TECHNOLOGY

SYSTEM: **ADVANCED LIGO** SUB-SYSTEM: **AOS**

MANIFOLD CRYO BAFFLE ASSY, ETM Y

DESIGNER	TG. NGUYEN	2 JUL 2011	SIZE	DWG. NO.	REV.
DRAFTER	TG. NGUYEN	12 OCT 2010	D	D1003228	v4
CHECKER	M. SMITH				
APPROVAL	D. COYNE				

SCALE: 1:12 PROJECTION:

SHEET 1 OF 5

D1003228.dwg: Manifold_Cryo_Baffle_Assembly_ETM_Y11_PART_PDM_REV_X025_DRAWING_PDM_REV_X012

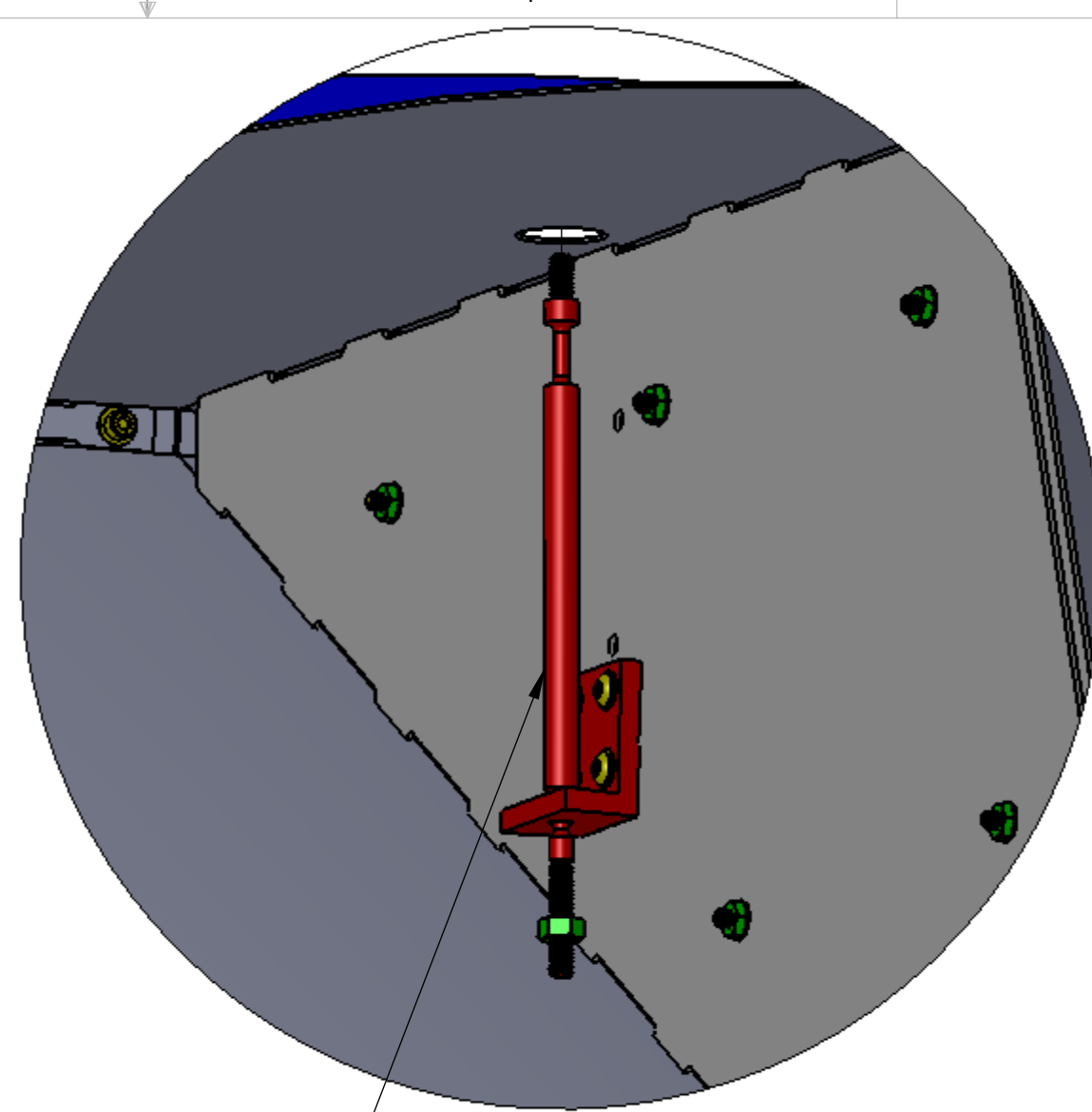
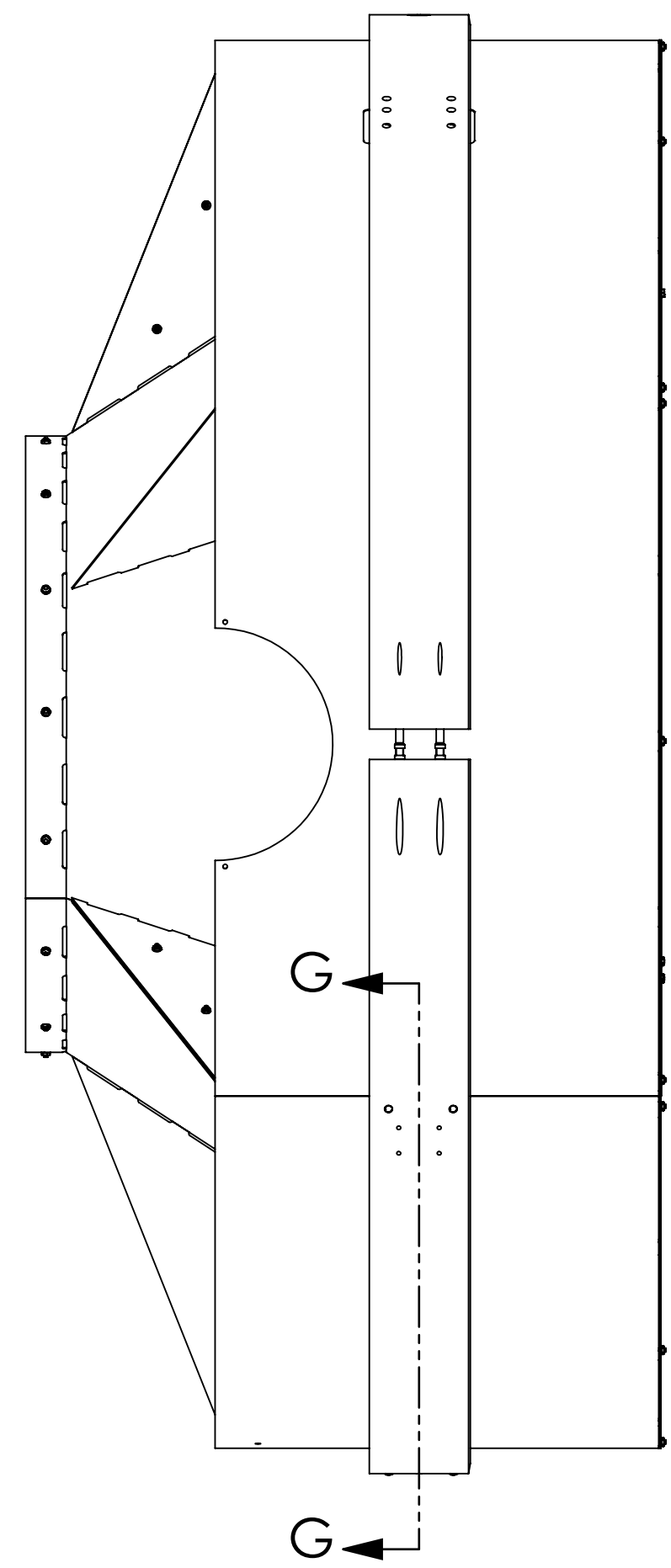
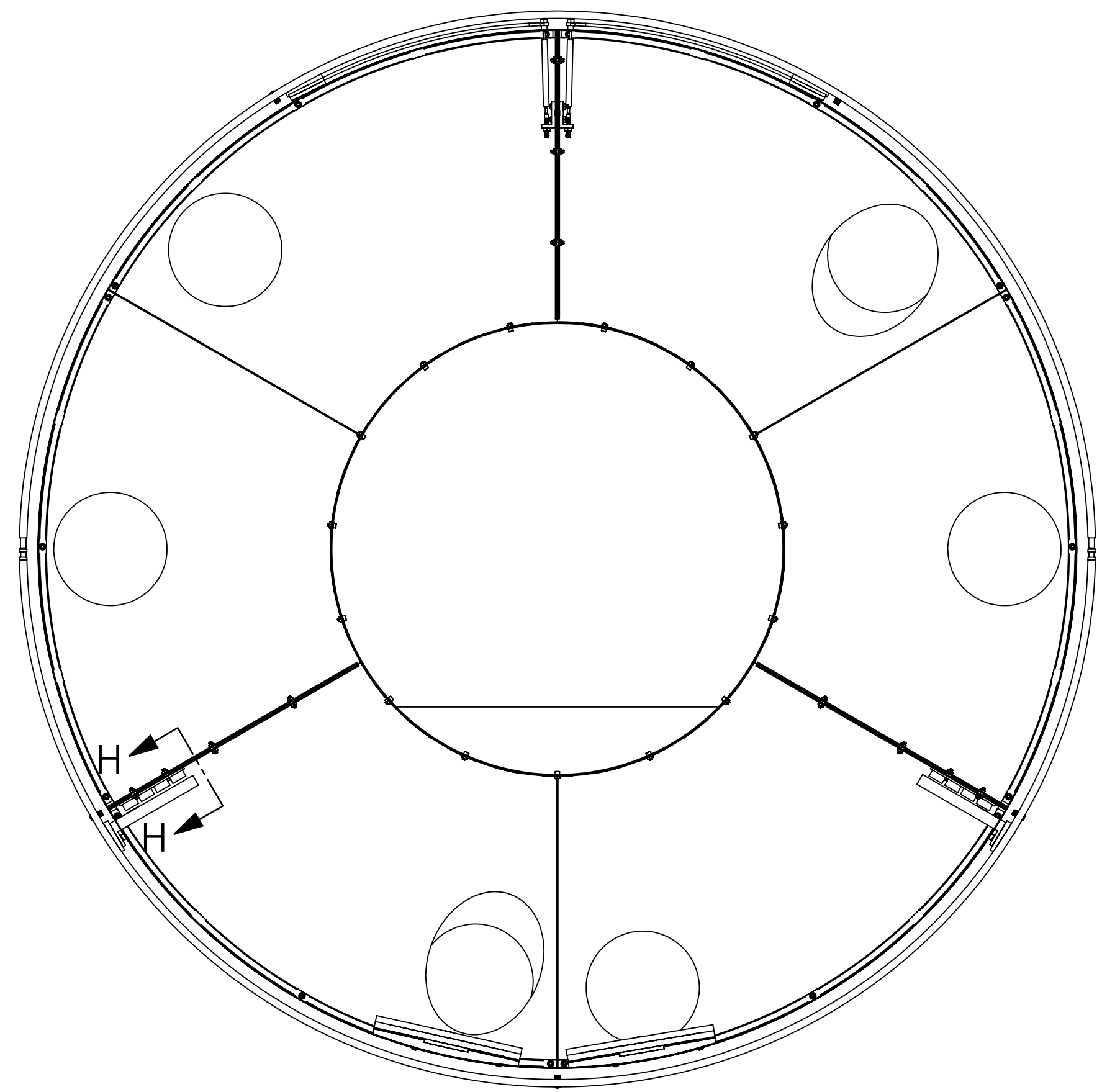

DETAIL C
SCALE 1 : 2

INSERT SUSPENSION ROD AND SECURE IT WITH WASHER & NUT BEFORE BRING BAFFLE IN TO MOUNT ON SUSPENDED SPRING PLATES.

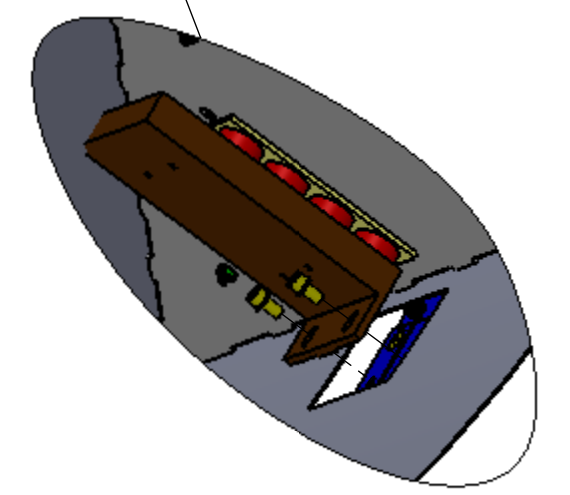
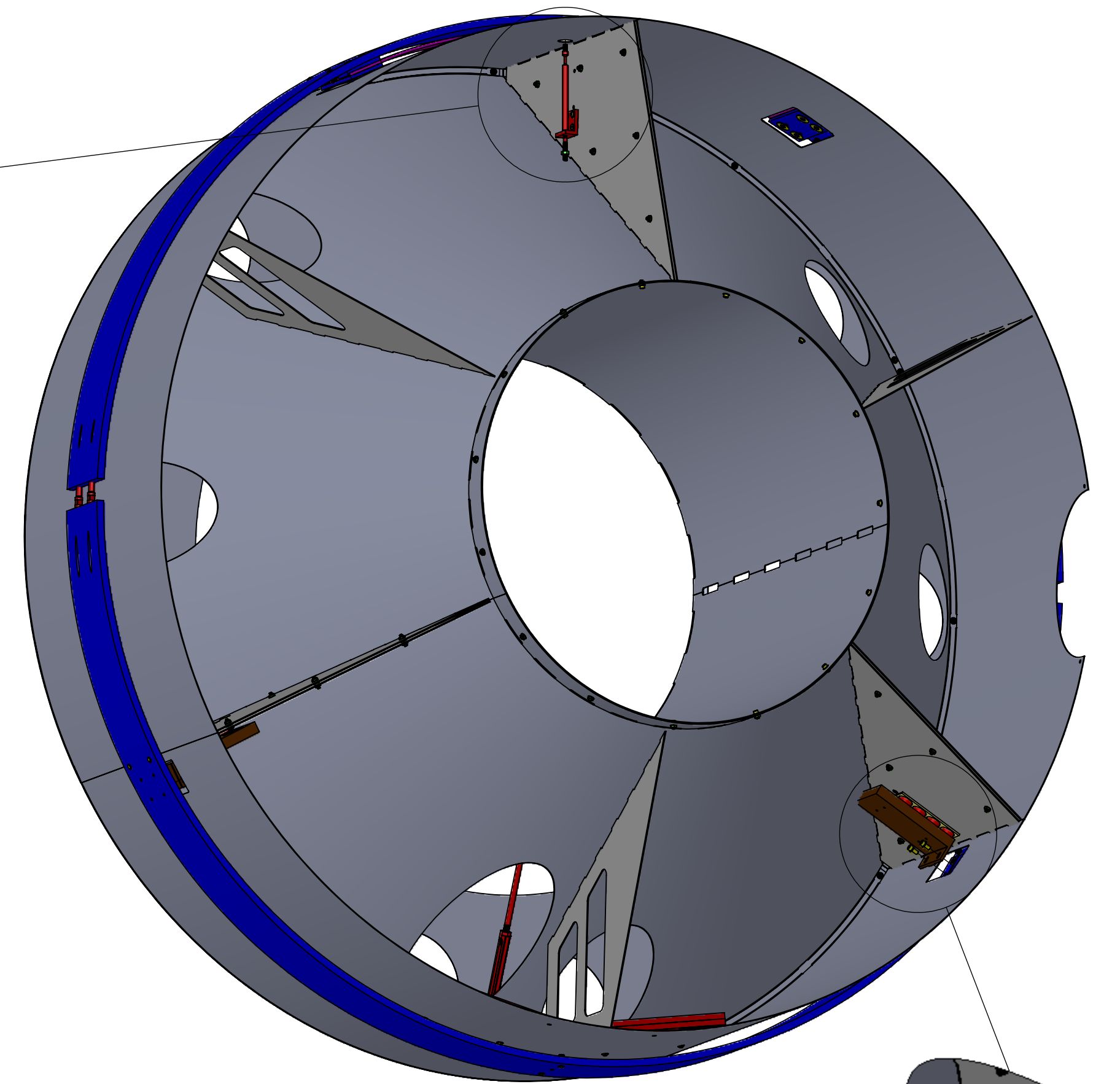

DETAIL D
SCALE 1 : 4

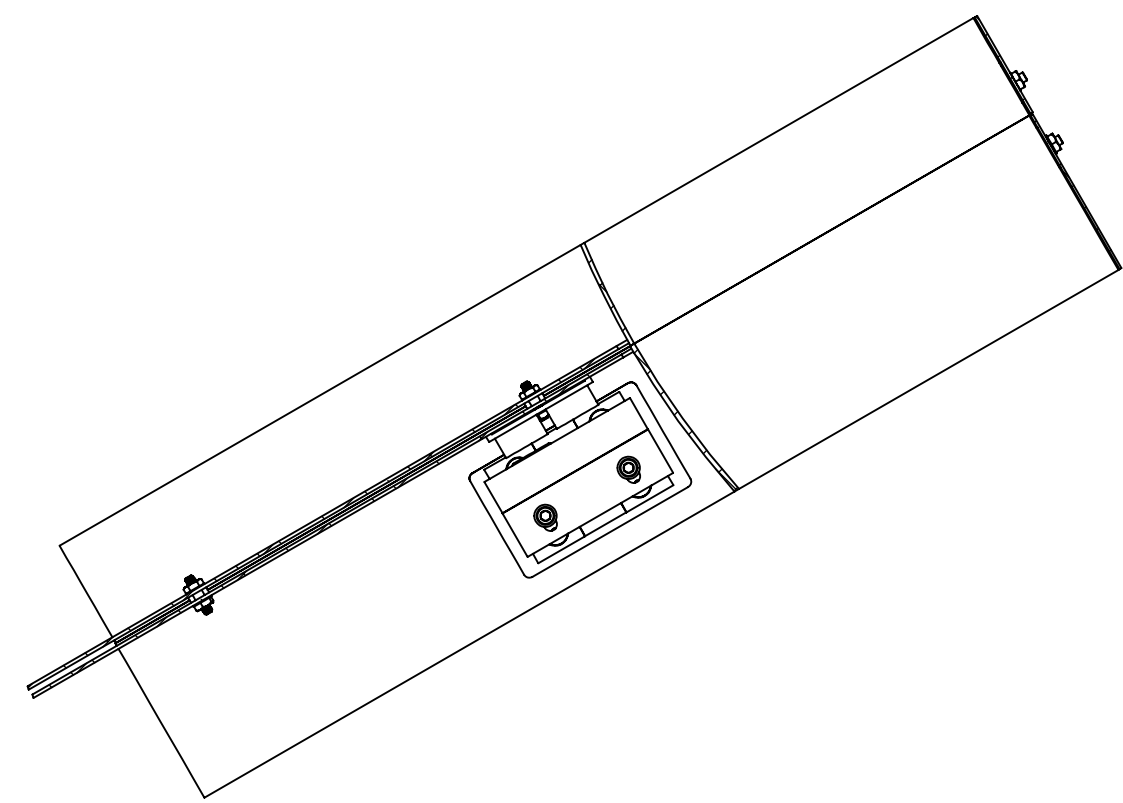

SECTION H-H
SCALE 1 : 4

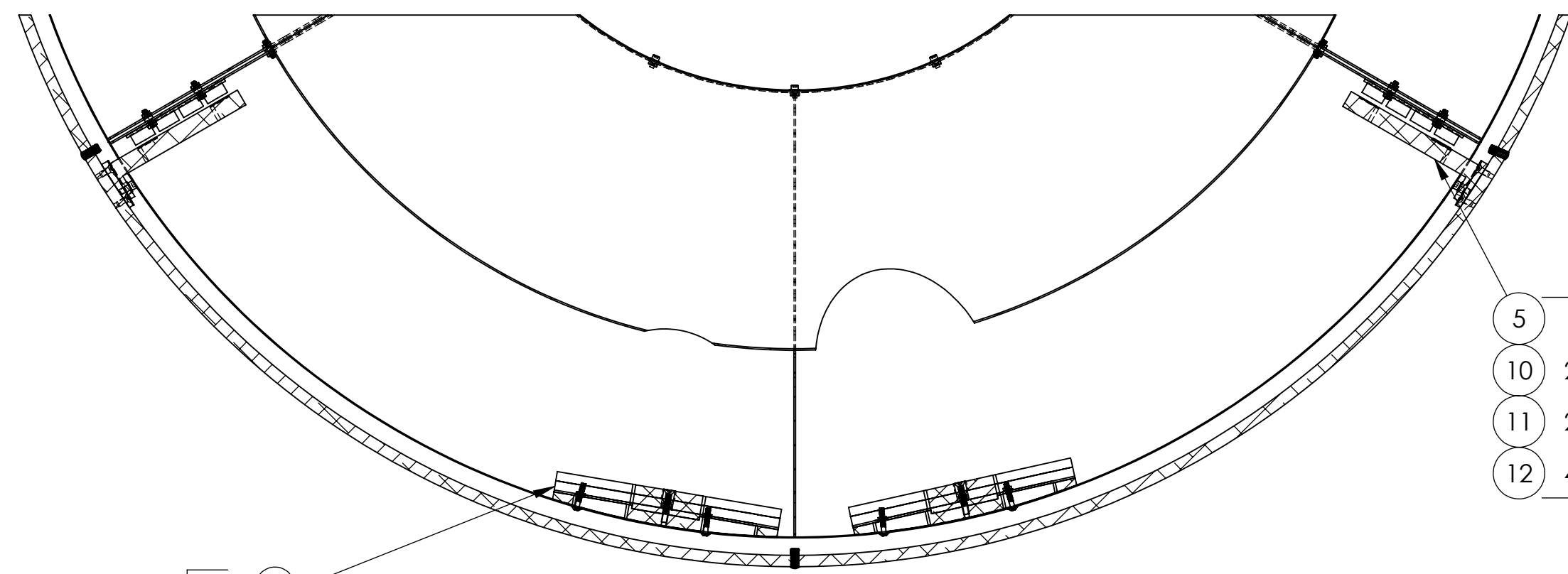

SECTION G-G
SCALE 1 : 6

- 3
- 2X 8
- 4X 7
- 2X 9

- 5
- 10 2X
- 11 2X
- 12 4X

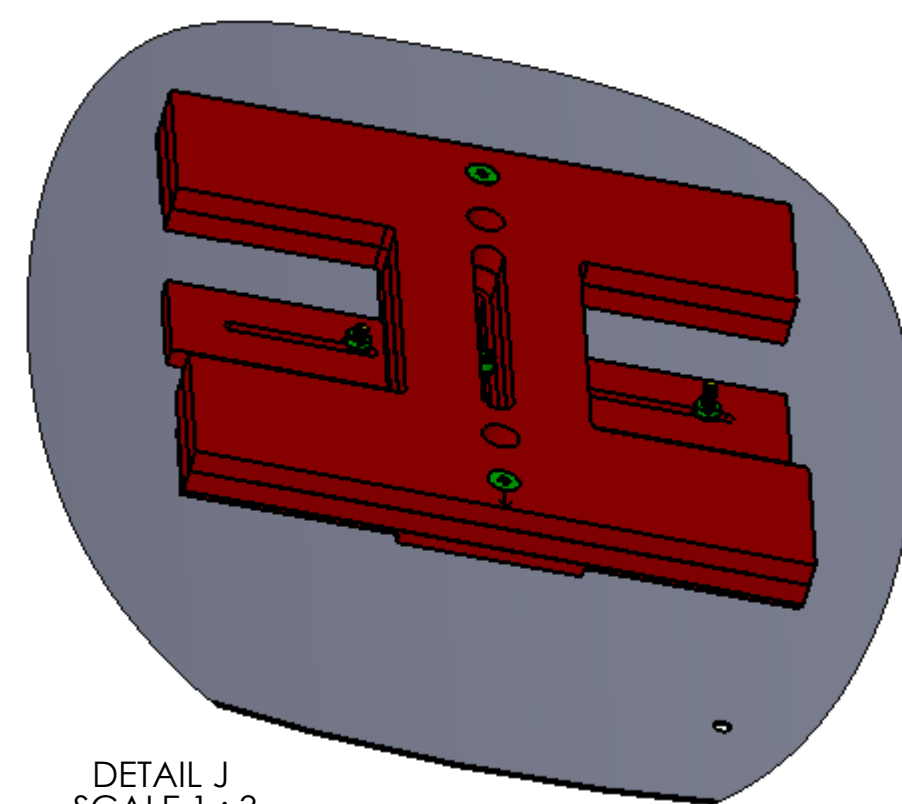

DETAIL J
SCALE 1 : 3

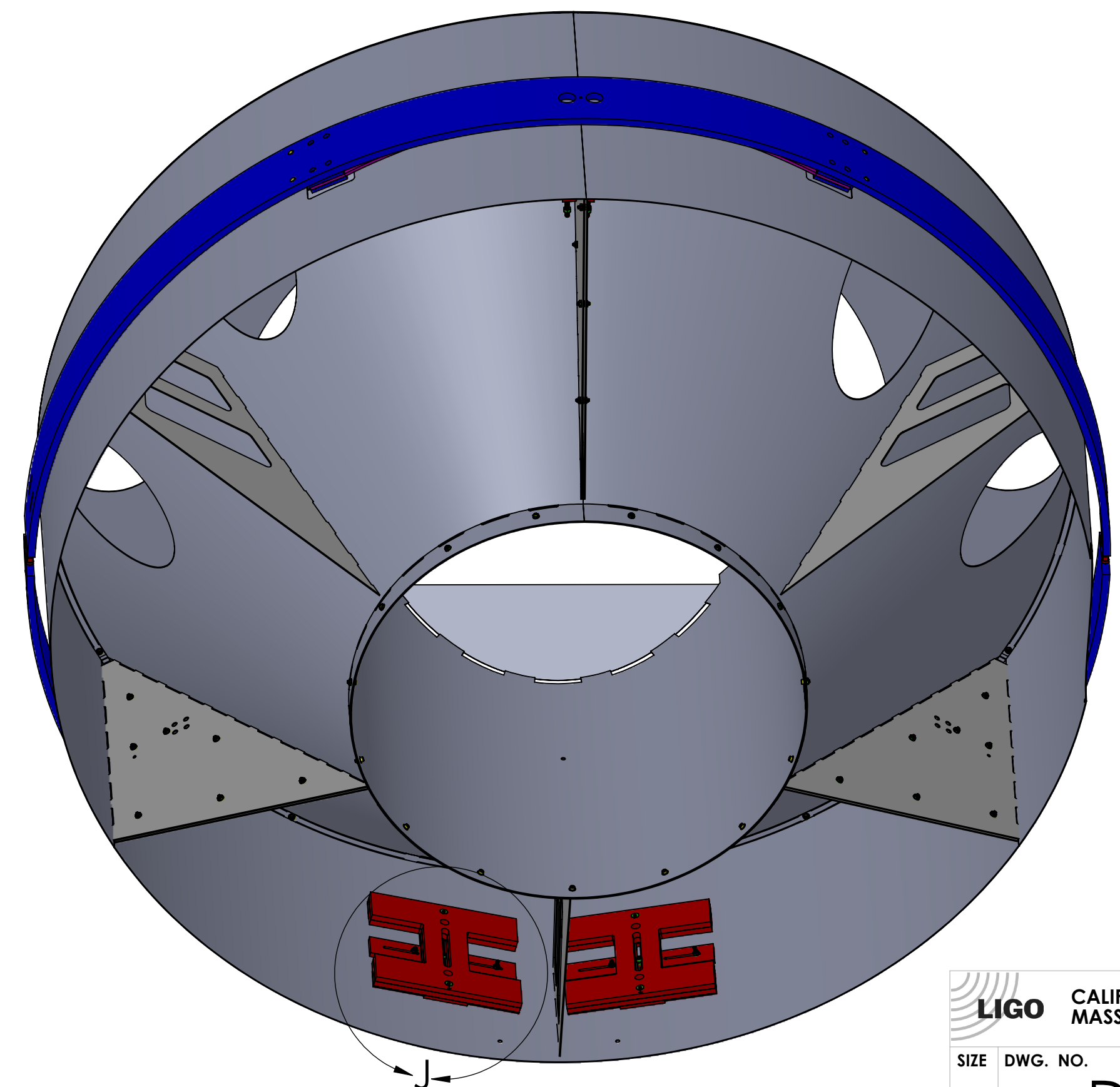

LIGO CALIFORNIA INSTITUTE OF TECHNOLOGY
MASSACHUSETTS INSTITUTE OF TECHNOLOGY

SIZE	DWG. NO.	REV.
D	D1003228	v4
SCALE: 1:8	PROJECTION:	SHEET 2 OF 5

D1003228.dwg_Montréal_Cryo_Baffle_Assembly_EIWI_H11_PART_PDM_REV_X-025_DRAWING_PDM_REV_X-012

INSTALLATION OF MANIFOLD CRYOPUMP BAFFLE INTO A-7 ADAPTER (LHO & LLO Y-END STATION)

1) PARTIAL VE LAYOUT (LHO & LLO Y-END STATION)

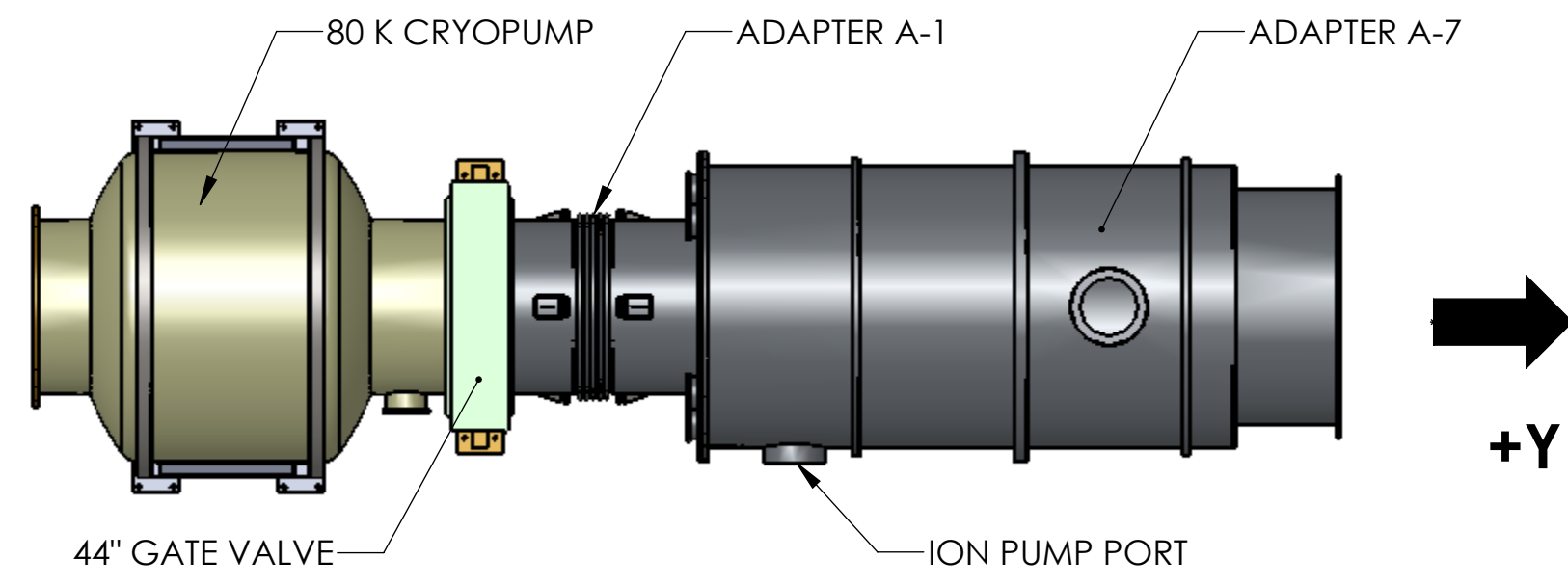

3) INSTALL FLANGE PROTECTOR & ALIGNMENT TOOLING AT A-7 ADAPTER

USING TEMPORARILY THE SAME HARDWARE (BOLT, NUT & WASHER) USED WHEN A-1 ADAPTER IS ATTACHED TO A-7 ADAPTER, INSTALL FLANGE PROTECTOR & ALIGNMENT TOOLING AS SHOWN IN DETAIL VIEW.

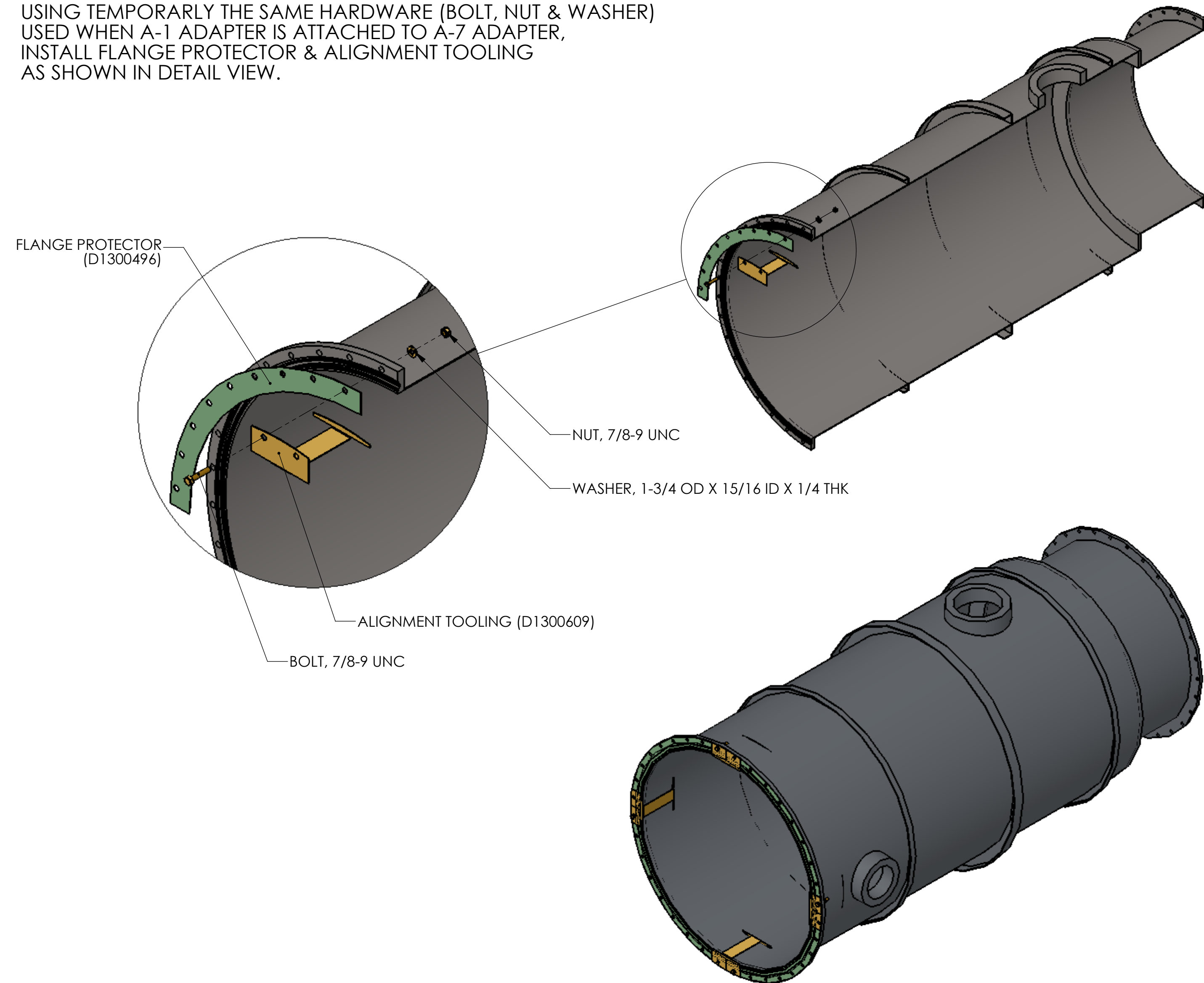

INSTALL 4X FLANGE PROTECTOR (D1300496) & 4X ALIGNMENT TOOLING (D1300609) EQUALLY SPACED AT 90° AS SHOWN.

2) REMOVE A-1 ADAPTER

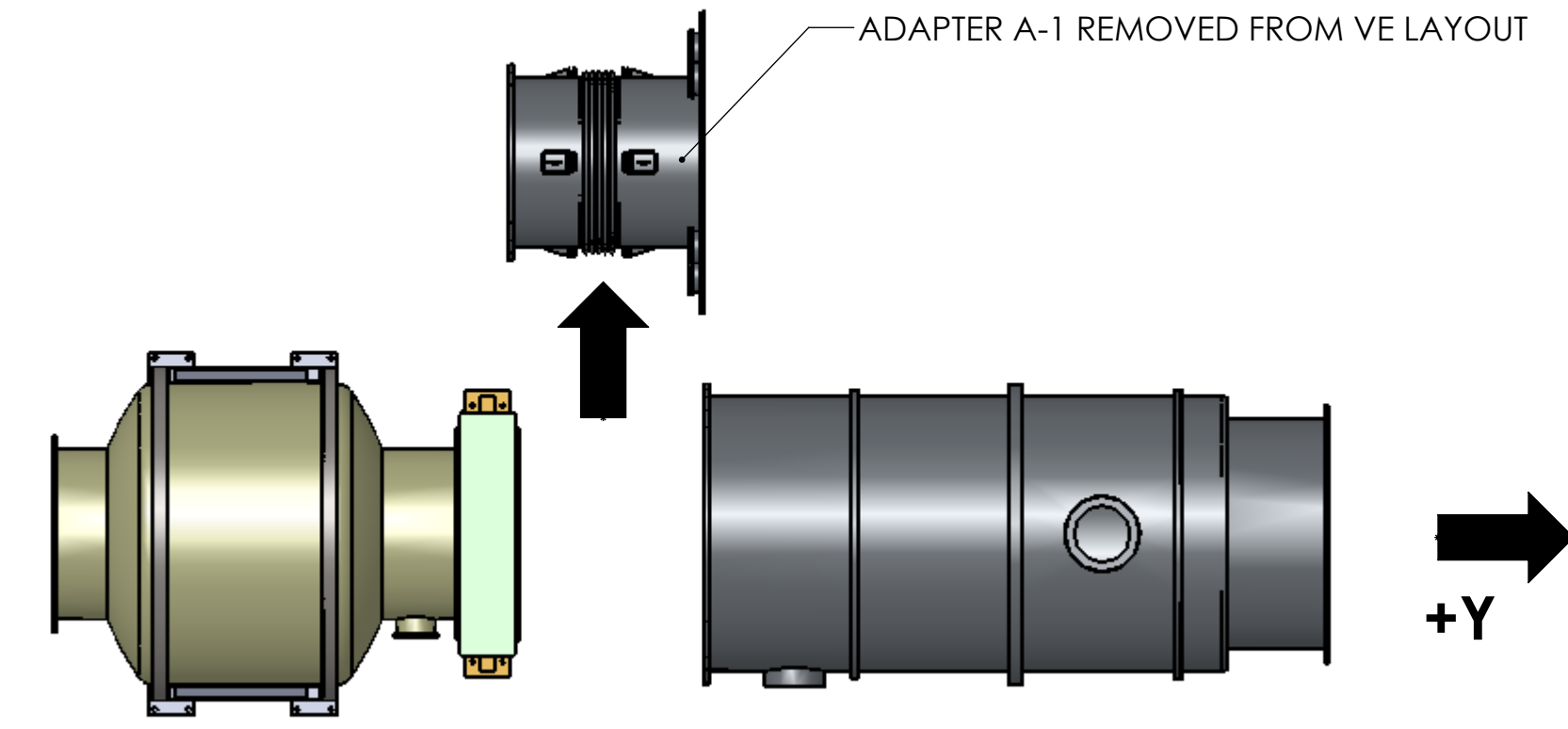

4) INSERT PCAL-VIDEO CAM PERISCOPE INSIDE A-7 ADAPTER

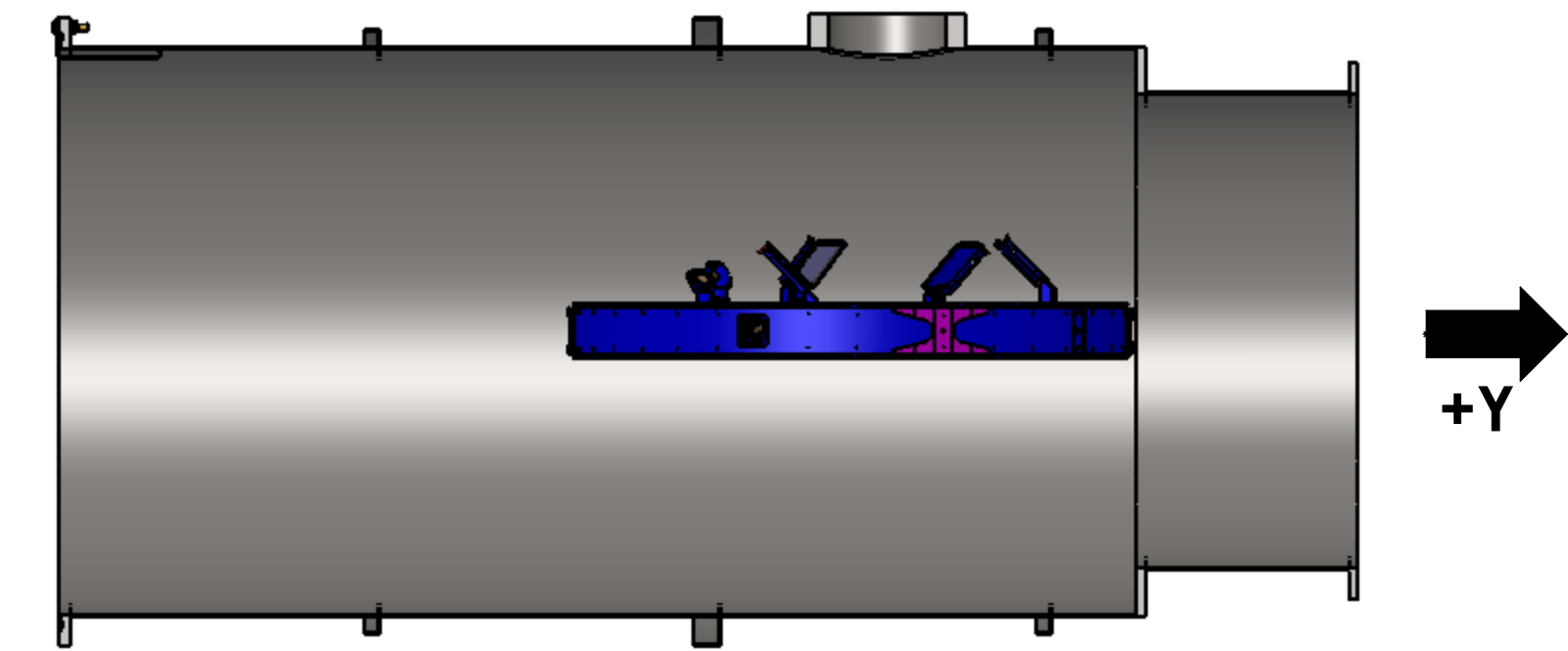

INSERT PCAL-VIDEO CAM PERISCOPE INSIDE A-7 ADAPTER FAR ENOUGH TO HAVE ROOM TO INSERT CRYOPUMP BAFFLE. LAID IT DOWN HORIZONTALLY TO ALLOW ACCESS OF PERSONNEL ENTERING FROM BSC CHAMBER TO WALK TO THE OPENING OF A-7 ADAPTER AND ASSIST IN THE INSTALLATION OF BAFFLE. (FINAL POSITION OF PCAL WILL BE DEFINED AFTER FINAL LOCATION OF CRYOPUMP BAFFLE).

5) INSERT SUPPORT RING ASSEMBLY (D1002084) INSIDE A-7 ADAPTER

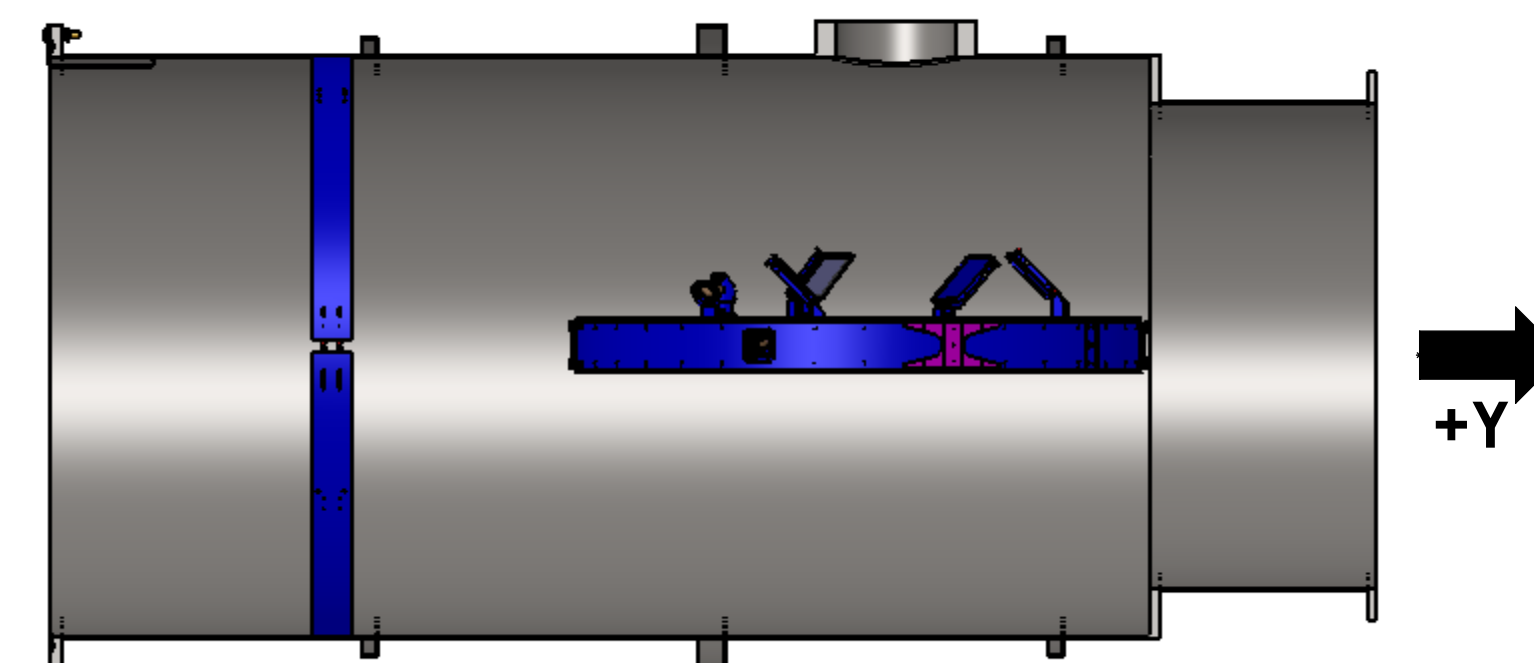

INSERT SUPPORT RING ASSEMBLY (D1002084) INTO A-7 ADAPTER FAR ENOUGH TO ALIGN IT PROPERLY AND POSITION IT AT THE FINAL LOCATION AS PER THE ALIGNMENT TOOLING. NOTE: THE BEVELED SIDE OF THE SUPPORT RING MUST FACE TOWARD THE ETMY

6) INSTALL PLUMB BOB ALIGNMENT ASSEMBLY (D1102170) INTO SUPPORT RING ASSEMBLY

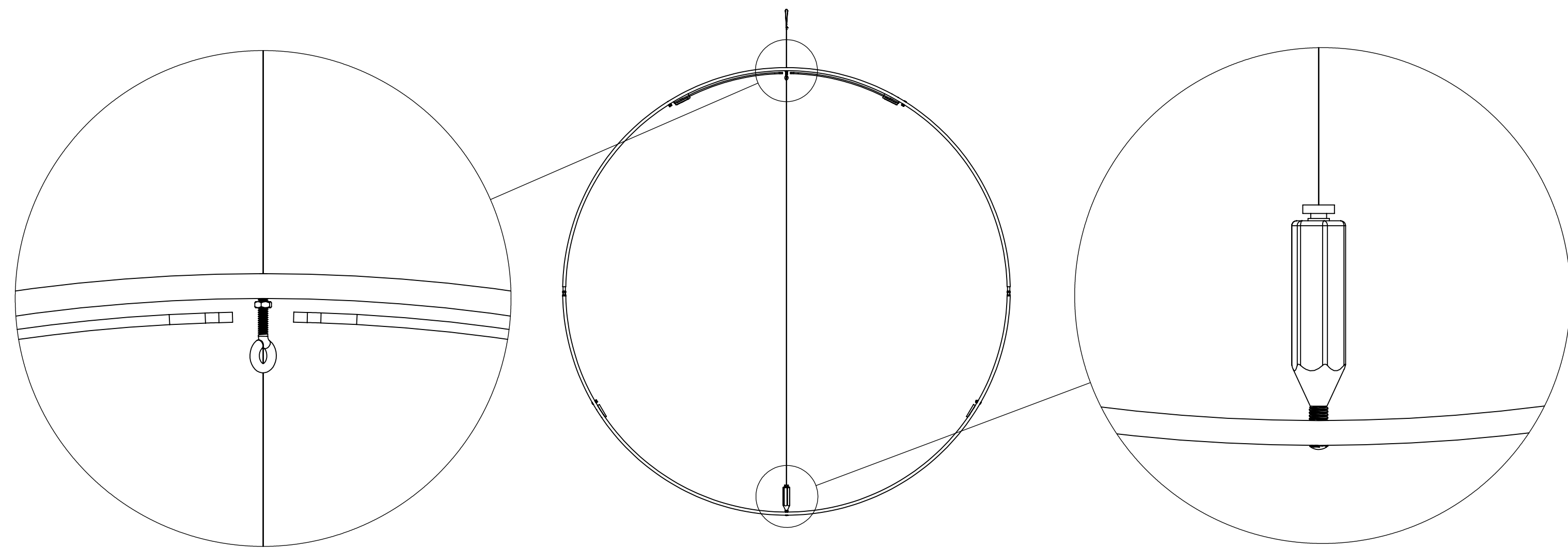

ATTACH THE PLUMB BOB ASSEMBLY FROM THE 10-32 TAPPED HOLE AT THE CENTER OF THE TOP RING

HANG DOWN PLUMB BOB ASSEMBLY TO JUST ABOVE THE .25" CLEARANCE HOLE AT THE CENTER OF THE BOTTOM RING

7) DEFINE LOCATION OF SUPPORT RING ASSEMBLY

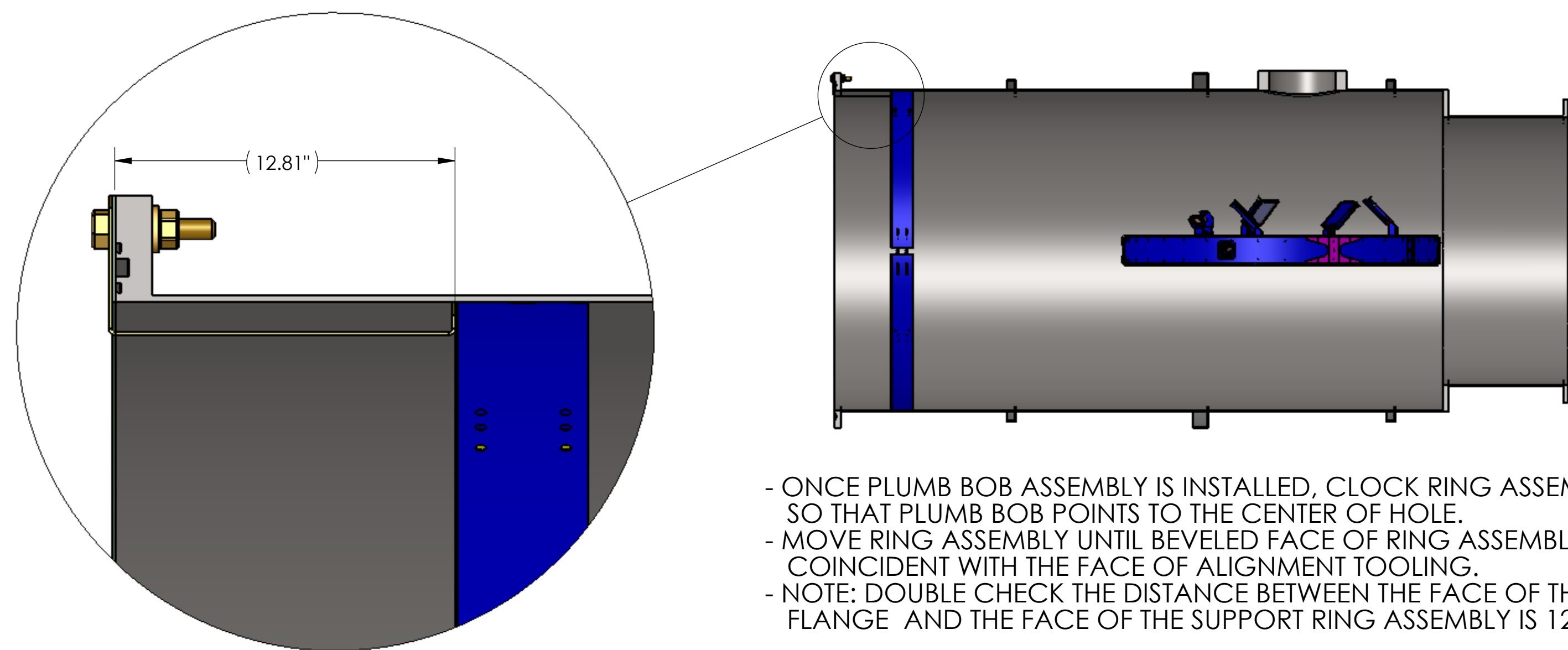

- ONCE PLUMB BOB ASSEMBLY IS INSTALLED, CLOCK RING ASSEMBLY SO THAT PLUMB BOB POINTS TO THE CENTER OF HOLE.
- MOVE RING ASSEMBLY UNTIL BEVELED FACE OF RING ASSEMBLY IS COINCIDENT WITH THE FACE OF ALIGNMENT TOOLING.
- NOTE: DOUBLE CHECK THE DISTANCE BETWEEN THE FACE OF THE FLANGE AND THE FACE OF THE SUPPORT RING ASSEMBLY IS 12.81".

8) SECURE THE SUPPORT RING ASSEMBLY

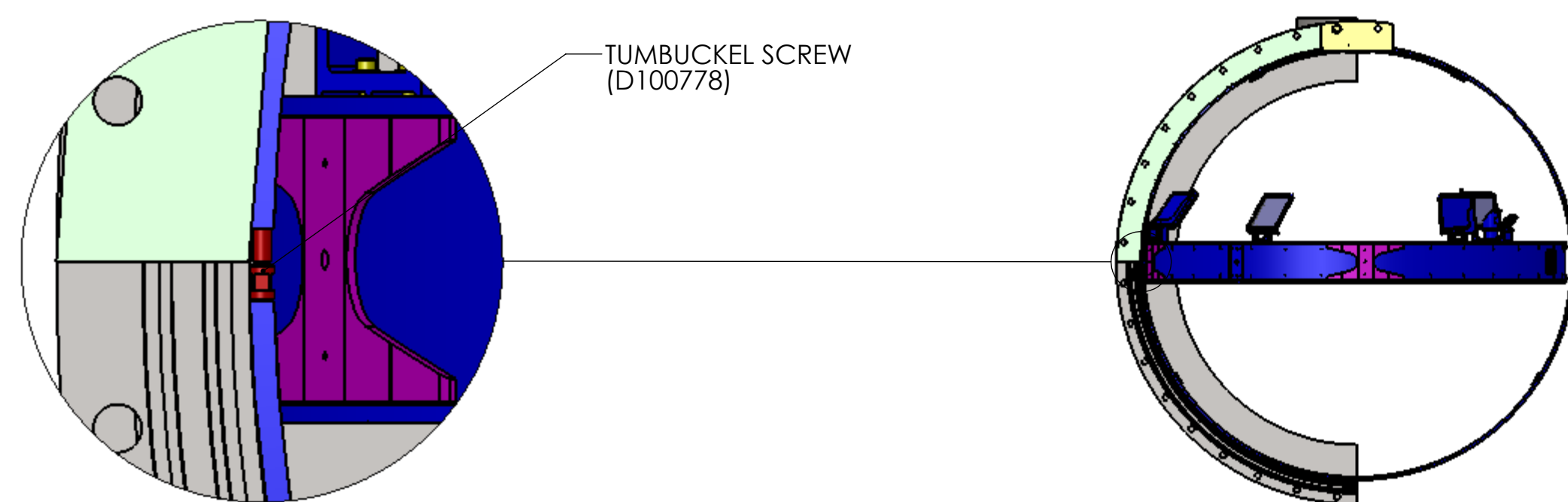

ONCE THE LOCATION OF THE RING ASSEMBLY IS DEFINED, SECURE IT AGAINST THE INSIDE WALL OF THE A-7 ADAPTER BY TIGHTENING THE TUMBUCKLE SCREW

9) COMPLETE INSTALLATION OF THE MANIFOLD CRYOPUMP BAFFLE ASSEMBLY

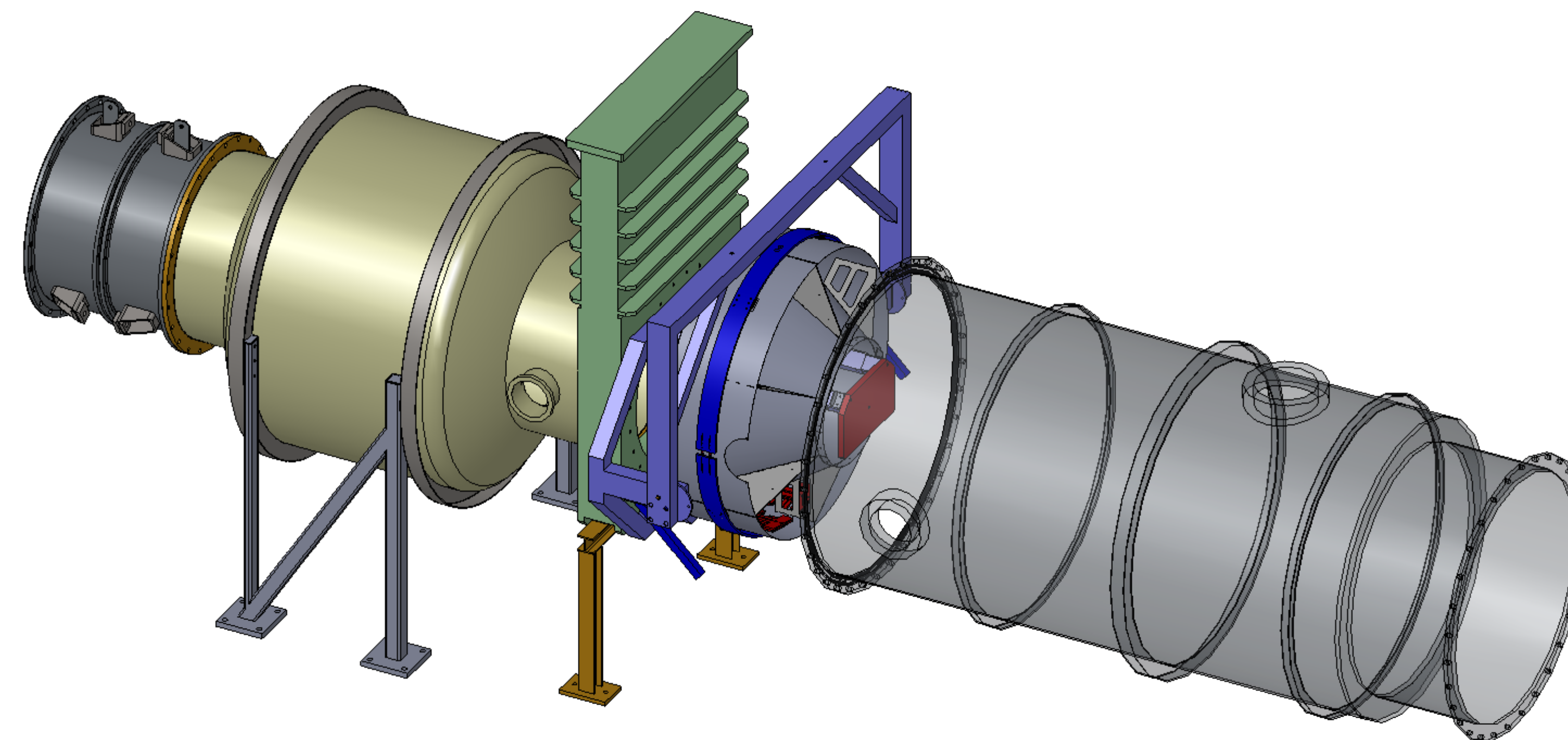

- ATTACH THE LIFT FIXTURE ASSEMBLY (D1101192) TO AN OVERHEAD LIFTING CRANE BY MEANS OF LIFTING STRAPS.
- MAKE SURE THE CUTOUT IN CRYOPUMP BAFFLE IS IN THE SAME SIDE AS THE ION PUMP PORT
- NOTE: FOR A DETAILED INSTALLATION PROCEDURE OF THE MANIFOLD CRYOPUMP BAFFLE REFER TO INSTALLATION DOCUMENT E1300577

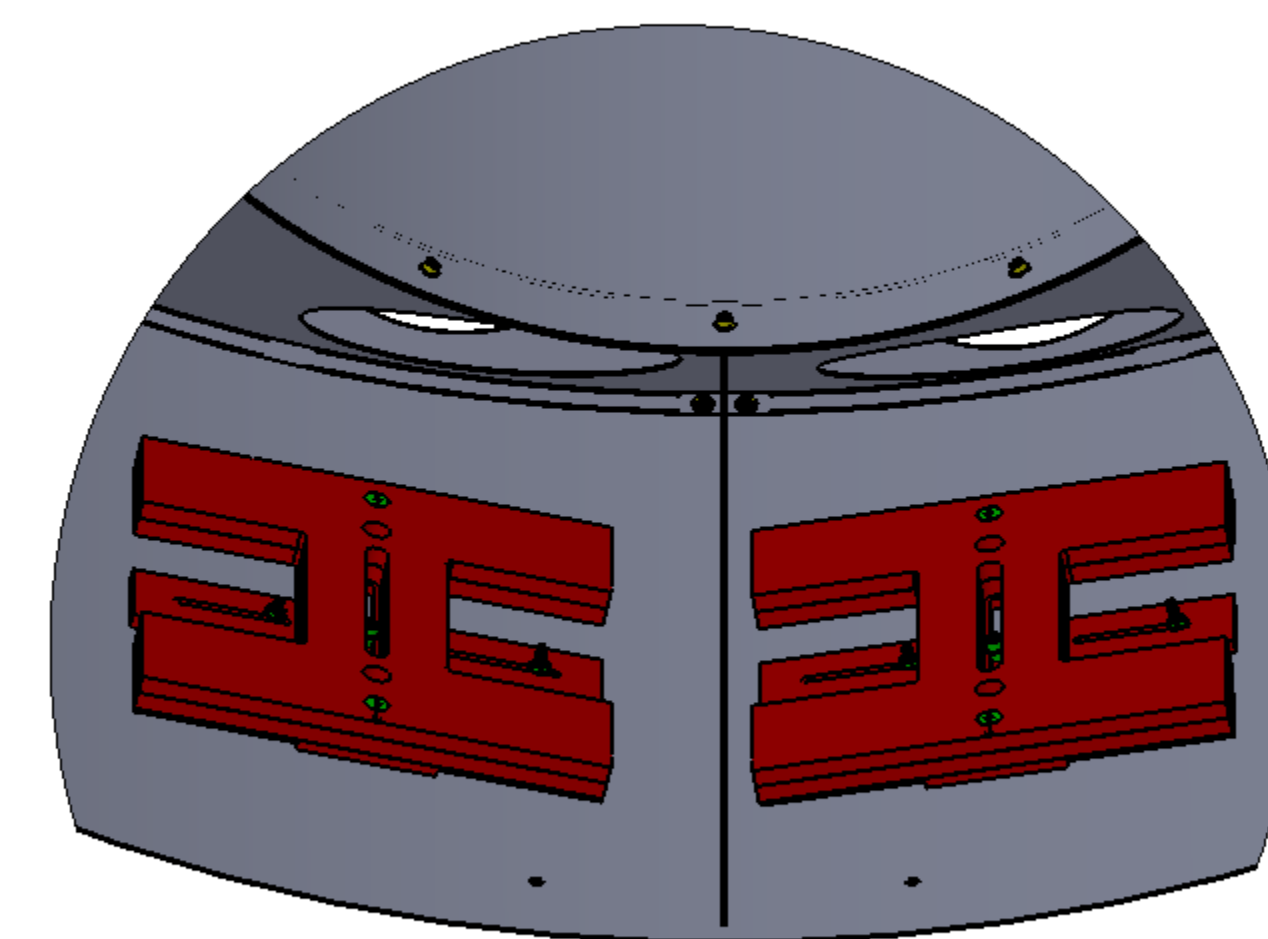

MAKE SURE THE BALANCE WEIGHT ASSEMBLY (D1002402) IS THE CORRECT ORIENTATION OF THE ARROWS.

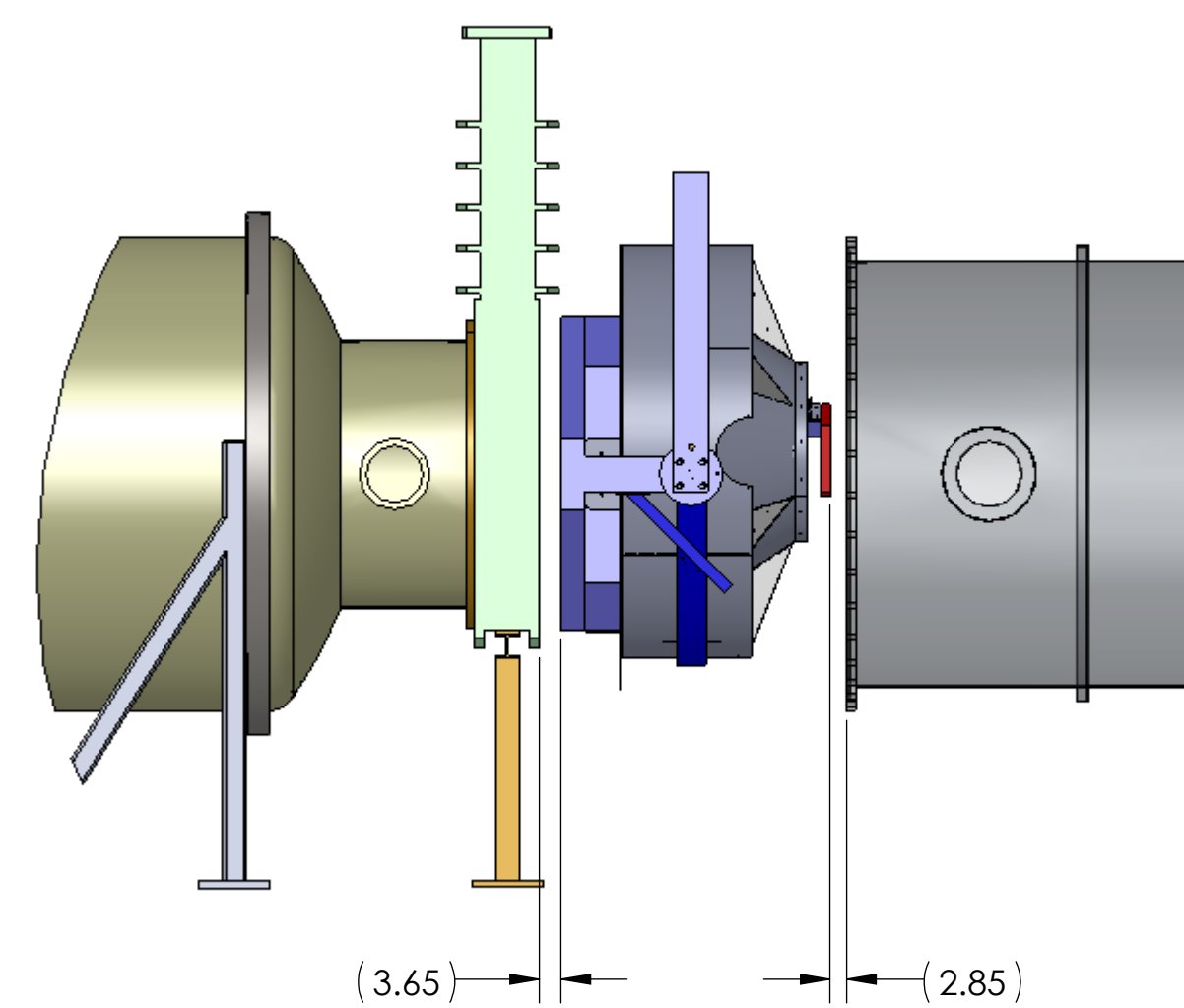

THERE IS A CLEARANCE OF ABOUT 6.5" BETWEEN THE GATE VALVE AND THE A-7 ADAPTER TO MANIPULATE THE LIFT FIXTURE WITH THE CRYOPUMP BAFFLE ASSEMBLY

10) CRYOPUMP BAFFLE FINAL LOCATION INSIDE A-7 ADAPTER AT LHO & LLO Y-END STATION

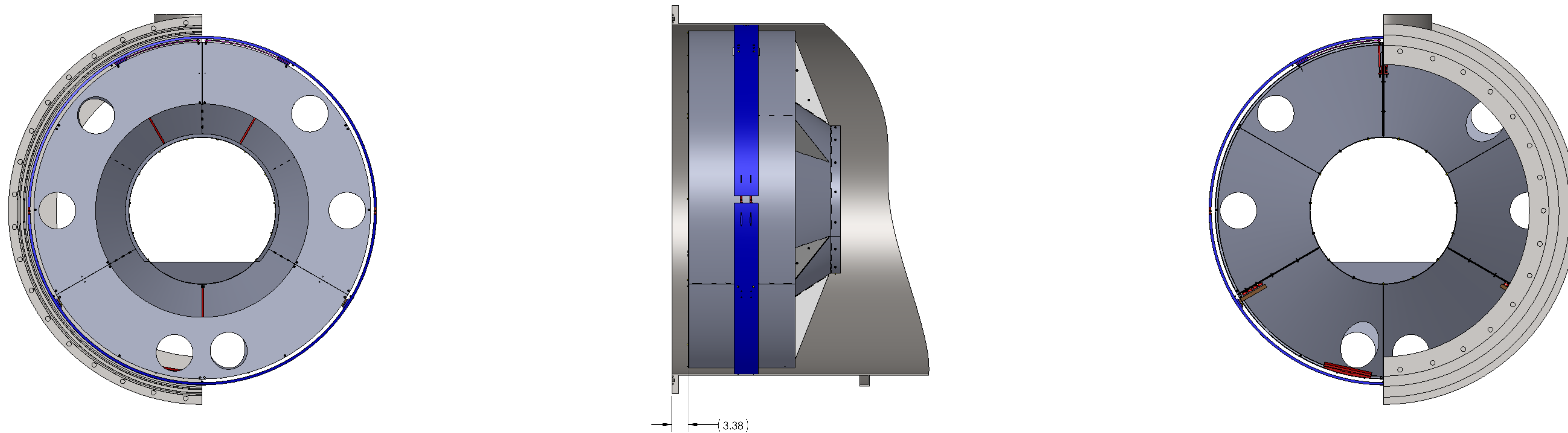

11) TOP VIEW (ROTATED 90° CW) WITH CRYOPUMP BAFFLE FINAL LOCATION AT LHO & LLO Y-END STATION

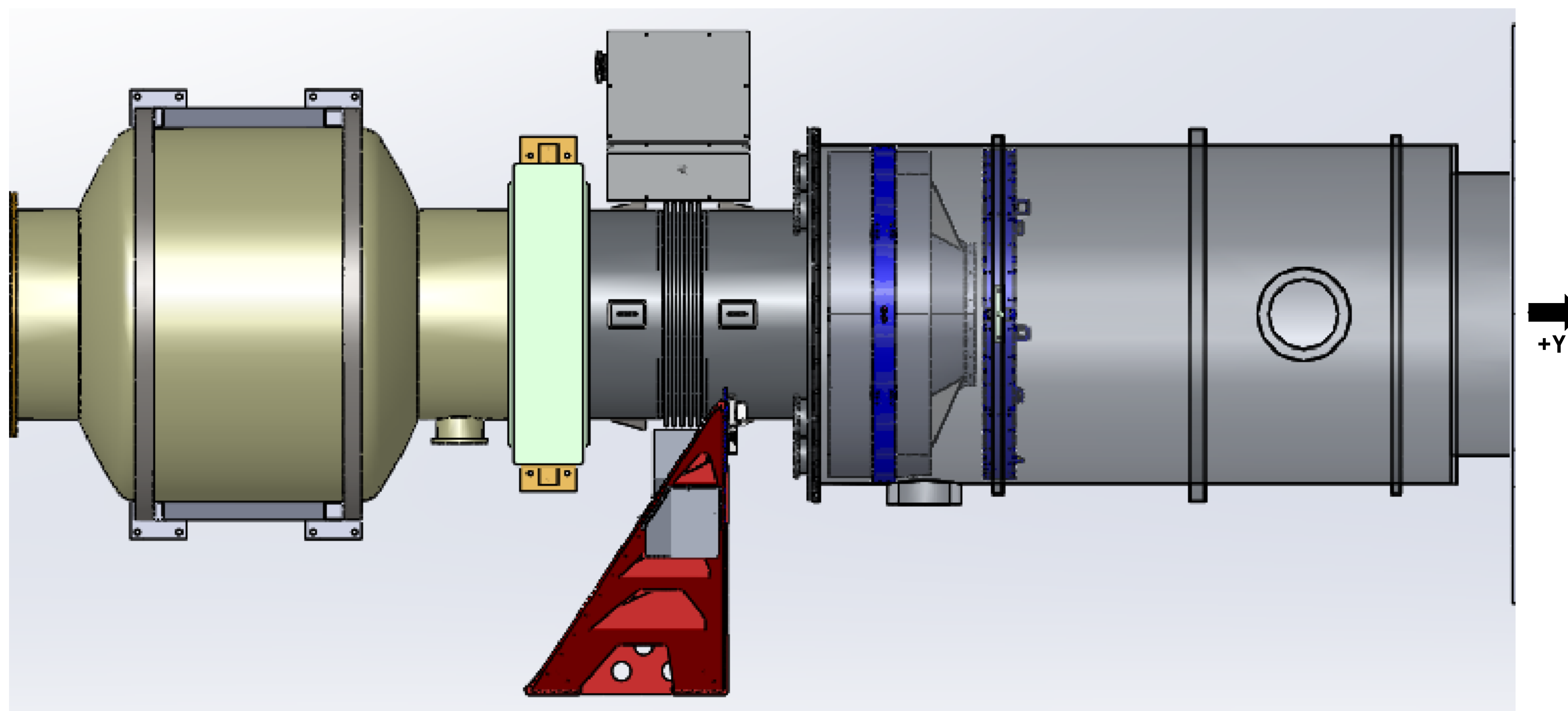

D1003228.dwg_Montréal_Cryo_Baffle_Assembly_EIMY111_PART_PDM_REV_X-025_DRAWING_PDM_REV_X-012