

- NOTES CONTINUED:**
- 5) SCRIBE, ENGRAVE, LASER MARK OR MECHANICALLY STAMP (NO DYES OR INKS) A UNIQUE THREE DIGIT SERIAL NUMBER & REVISION NUMBER ON EACH PART. SERIAL NUMBERS START AT 001 FOR THE FIRST ARTICLE AND PROCEED CONSECUTIVELY. BAG AND TAG PARTS WITH THEIR DRAWING PART NUMBER, REVISION, VARIANT OR "TYPE" (IF APPLICABLE), AND QUANTITY. IF PARTS ARE TOO SMALL TO SCRIBE, BAGGING AND TAGGING ALONE IS SUFFICIENT.
EXAMPLE (PART): 001-v1
EXAMPLE (TAG): DXXXXXX-VY, TYPE-XX, QTY: TBD
 - 6) INTERFACES TO TCS IN-AIR OPTICS TABLE ENCLOSURE
 - 7) BOLTS SHOWN PASS THROUGH EXISTING VACUUM FLANGE, WHICH IS NOT SHOWN
 - 8) MATERIAL: PEEK
 - 9) FUSED SILICA WINDOW SPEC. AS PRIMARY VIEWPORT AT VACUUM INTERFACE:
Ø 3±.010
CENTER THICKNESS: .5±.01
WEDGE: 3±2 MIN
BEVEL: .010 @ 45±10°
CLEAR APERTURE: Ø 2.75
SURFACE FIGURE: <LAMBDA/10 @ 633nm
SURFACE QUALITY: 10/5 SCRATCH/DIG
 - 10) ASS68A AEROSPACE STANDARD ID NUMBER -146
INSIDE Ø 2.6250
OUTSIDE Ø 2.8130
THICKNESS: 3/32
MATERIAL: VITON
DUROMETER HARDNESS RATING: 70 SHORE A
MARCO RUBBER #B1000-146 OR EQUIVALENT
 - 11) ZnSe WINDOW SPEC. AS PRIMARY VIEWPORT AT VACUUM INTERFACE:
Ø 3±.005
CENTER THICKNESS: .5±.01
WEDGE: 60±5 MIN
BEVEL: .025±.005
SURFACE FIGURE: (LAMBDA/10) P-V @ 10.6 um
SURFACE QUALITY: 40/20 SCRATCH/DIG
COATING: AR/AR @ 10.6 um
 - 12) ITEMS 3 OR 13 AND 8 ARE SECURED TOGETHER WITH ITEM 9
TORQUE ITEM 9 TO 5 IN-LB [0.5 N-M]
 - 13) FOR SPECIFIED PROPERTIES GIVEN IN NOTE 10,
O-RINGS ARE EXPECTED TO COMPRESS UP TO 25% DUE TO VACUUM PRESSURE
LEAVING .030 GAP BETWEEN OPTICS AND ADJACENT METALLIC PARTS

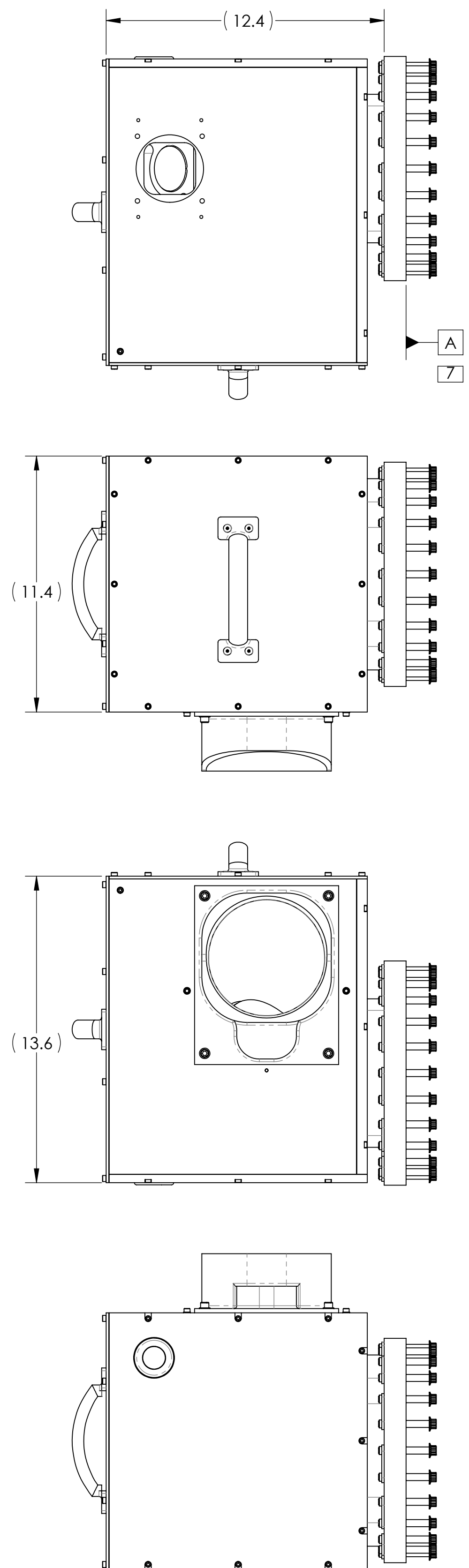

TYPE (CONFIGURATION)	DESCRIPTION
-01	αLIGO, TCS, H2, X-ARM (SHOWN)
-02	αLIGO, TCS, Y-ARM (MIRROR OF -01)

REV.	DATE	DCN #	DRAWING TREE #
v2	27 JUL 2011	E1100655-v1	E1100656-v1

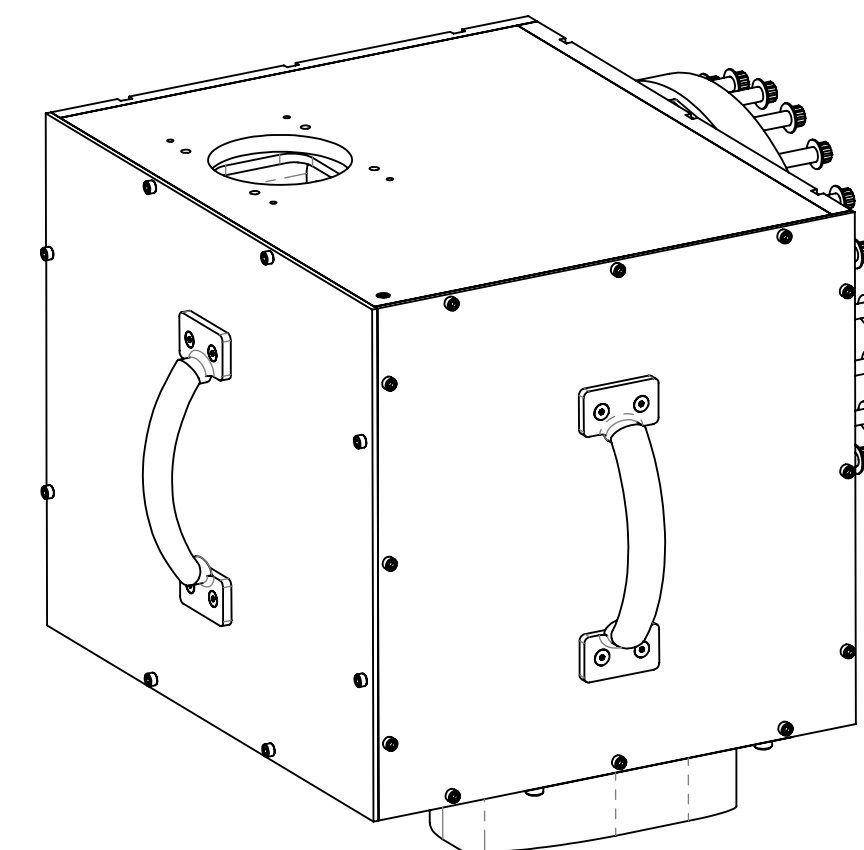

TYPE -01

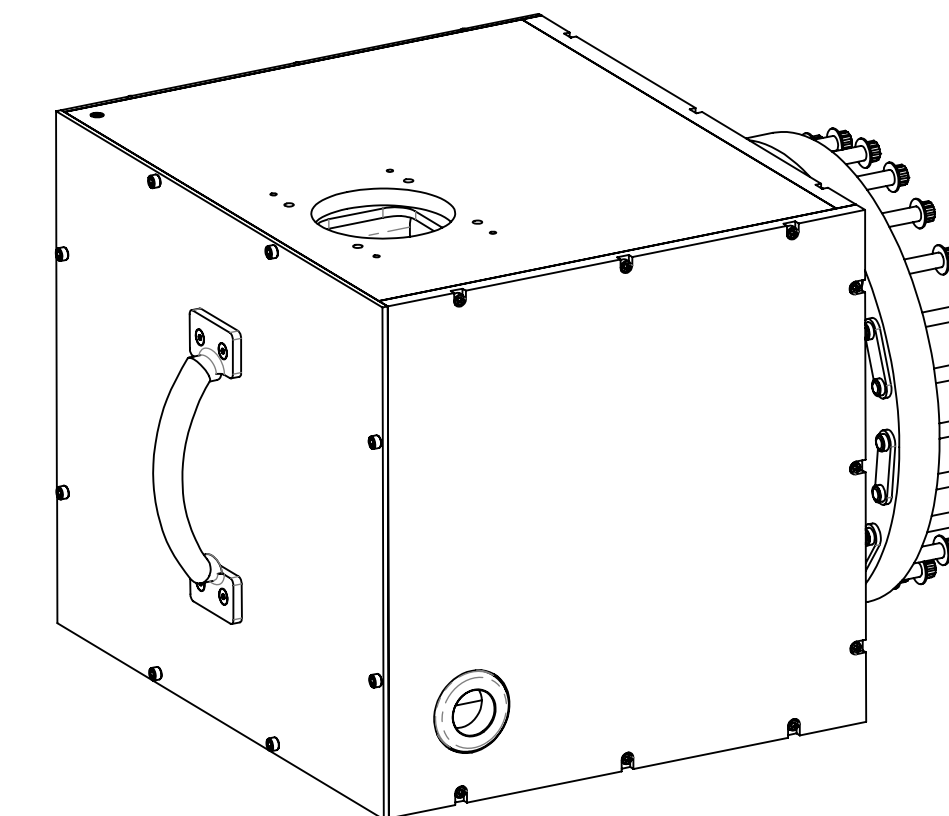

TYPE -02

ITEM NO.	PART NUMBER	DESCRIPTION	MATERIAL	REQ/-01	REQ/-02	SPARE	TOTAL
17	D1101145-01	TOP PERISCOPE MOUNT ASSEMBLY, H2 CO2P	N/A	1	-	0	1
16	D1003217-01	VP ENCLOSURE BACK COVER ASSY, CO2P	N/A	1	-	0	1
15	D1003210-01	VP ENCLOSURE SIDE OPTOMECH ASSY, CO2P	N/A	1	-	0	1
14	D1003204-01	VP ENCLOSURE FRONT COVER ASSY, H2 CO2P	N/A	1	-	0	1
13	D1003214-01	VP ENCLOSURE TOP WALL, CO2P	6061 Alloy	1	-	0	1
12	D1003221-01	VP ENCLOSURE LOWER WALL ASSY, CO2P	N/A	1	-	0	1
11	D1101235	αLIGO TCS H2 Viewport Camera Mirror Assembly	N/A	1	1	0	2
10	D1101145-02	TOP PERISCOPE MOUNT ASSEMBLY, H2 CO2P	N/A	-	1	0	1
9	C-608-N	SHCS #6-32 X 0.5	18-8 S316	1	1	2	4
8	D1003219	MOUNTING ROD, SIDE-TO-BACK COVERS	6061 Alloy	1	1	0	2
7	D1003217-02	VP ENCLOSURE BACK COVER ASSY, CO2P	N/A	-	1	0	1
6	D1003215	VP ENCLOSURE SIDE COVER ASSY, CO2P	N/A	1	1	0	2
5	D1003221-02	VP ENCLOSURE LOWER WALL ASSY, CO2P	N/A	-	1	0	1
4	D1003194	PRIMARY FLANGE VIEWPORTS ASSY, CO2P	N/A	1	1	0	2
3	D1003214-02	VP ENCLOSURE TOP WALL, CO2P	6061 Alloy	-	1	0	1
2	D1003210-02	VP ENCLOSURE SIDE OPTOMECH ASSY, CO2P	N/A	-	1	0	1
1	D1003204-02	VP ENCLOSURE FRONT COVER ASSY, H2 CO2P	N/A	-	1	0	1

NOTES AND TOLERANCES: (UNLESS OTHERWISE SPECIFIED)	
DIMENSIONS ARE IN INCHES	
TOLERANCES: .XX ± .01 .XXX ± .005	
ANGULAR ± °	
1. INTERPRET DRAWING PER ASME Y14.5-1994. 2. REMOVE ALL SHARP EDGES, .005-.015, FOR MACHINED PARTS. ROUND ALL EDGES APPROXIMATELY R.02 FOR SHEET METAL PARTS. 3. DO NOT SCALE FROM DRAWING. 4. ALL MACHINING FLUIDS MUST BE FULLY SYNTHETIC, FULLY WATER SOLUBLE AND FREE OF SULFUR, SILICONE, AND CHLORINE.	
MATERIAL	N/A
FINISH	N/A μinch

LIGO CALIFORNIA INSTITUTE OF TECHNOLOGY MASSACHUSETTS INSTITUTE OF TECHNOLOGY		PART NAME	
ADVANCED LIGO		VIEWPORT ENCLOSURE ASSY, H2 CO2P	
DESIGNER	A. LYNCH	27 JUL 2011	SIZE DWG. NO.
DRAFTER	A. LYNCH	08 JUL 2011	D D1003193
CHECKER	M. JACOBSON	27 JUL 2011	REV. v2
APPROVAL	P. WILLEMS	30 MAR 2011	SCALE: 1:4 PROJECTION:
NEXT ASSY		D1000630	
PARTS LIST		SHEET 1 OF 4	

D1003193_αLIGO TCS Viewport Enclosure Assy, CO2P, PART PDM REV: X.133, DRAWING PDM REV: X.019

8 7 6 5 4 3 2 1

H
G
F
E
D
C
B
A

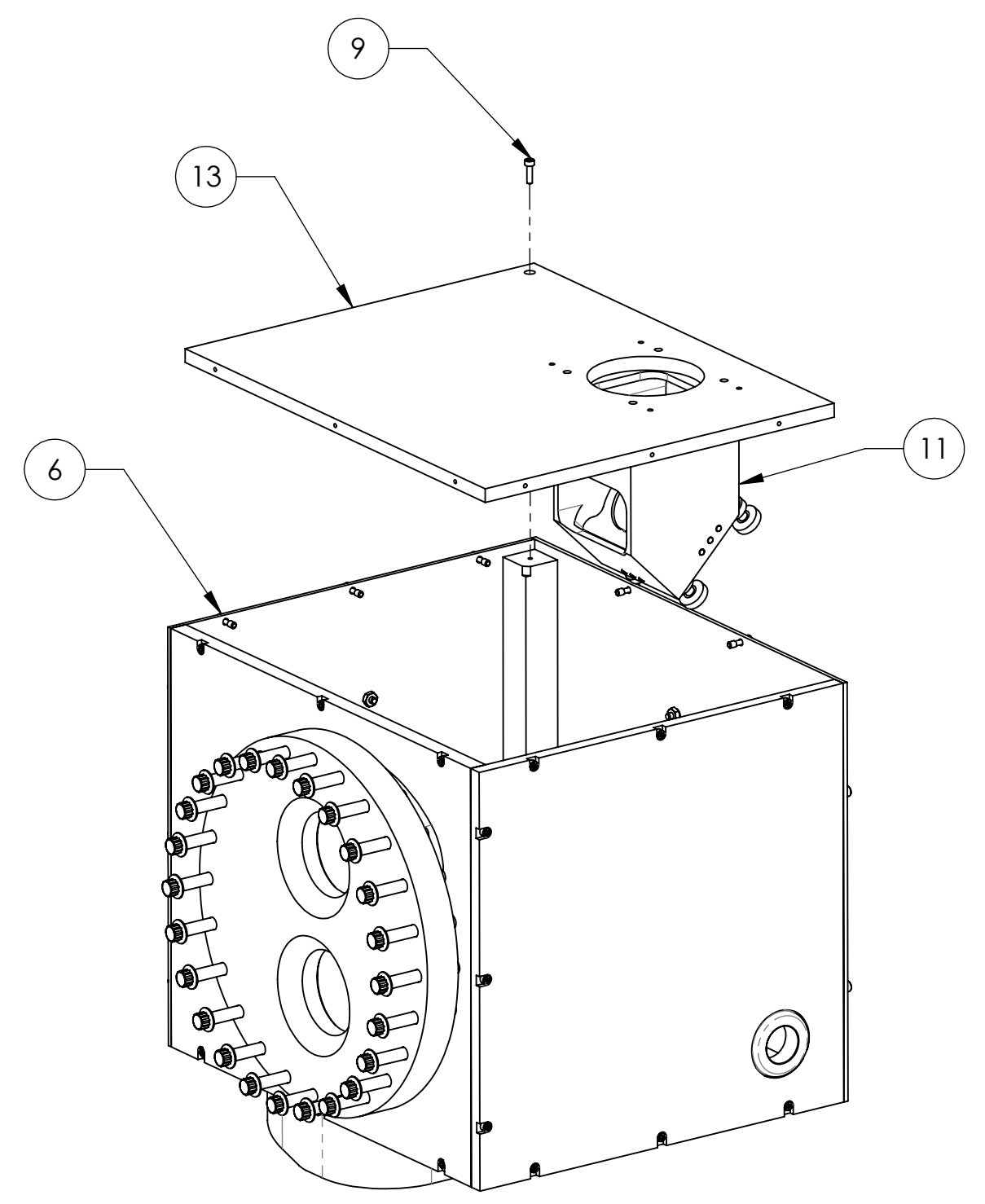
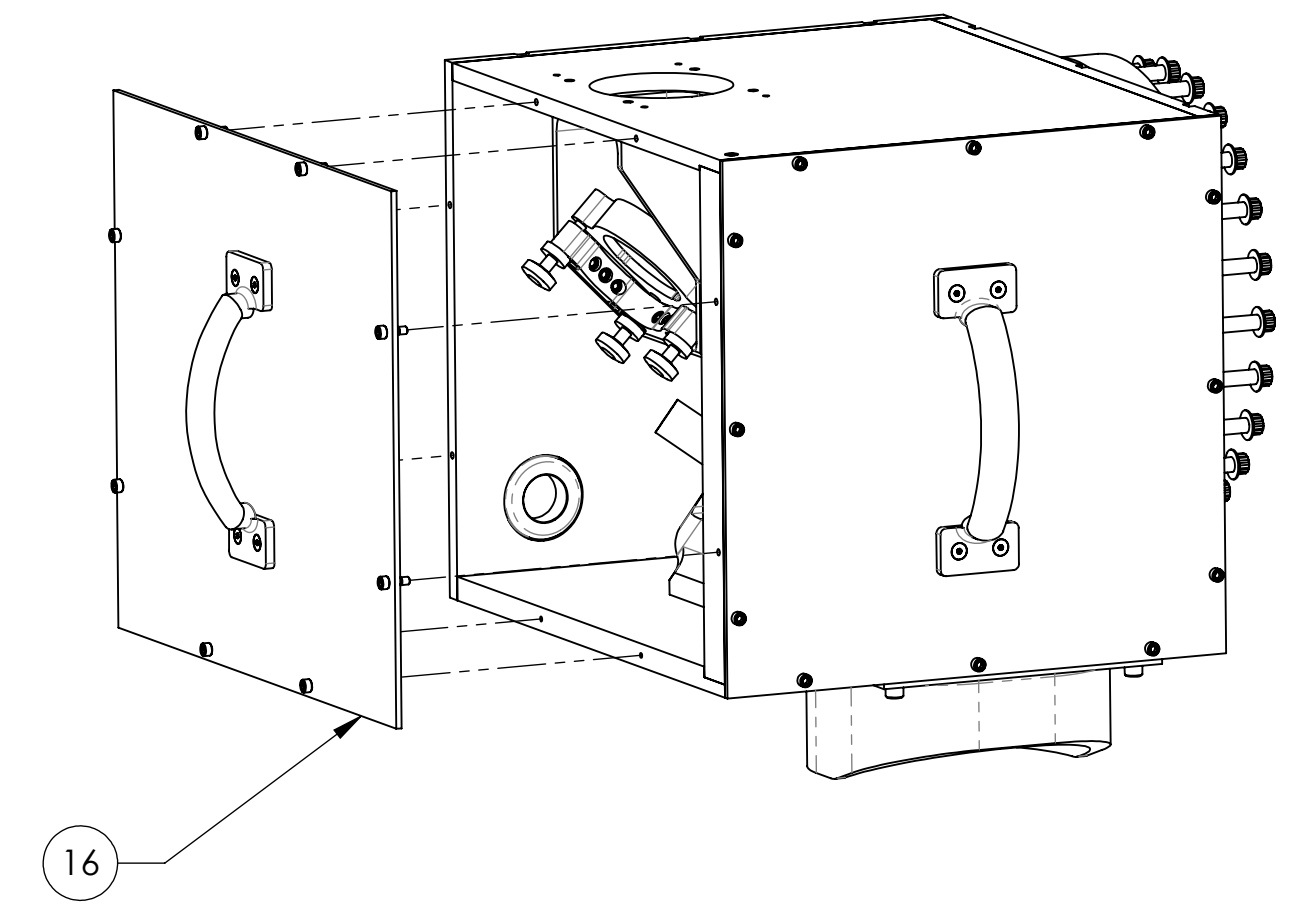
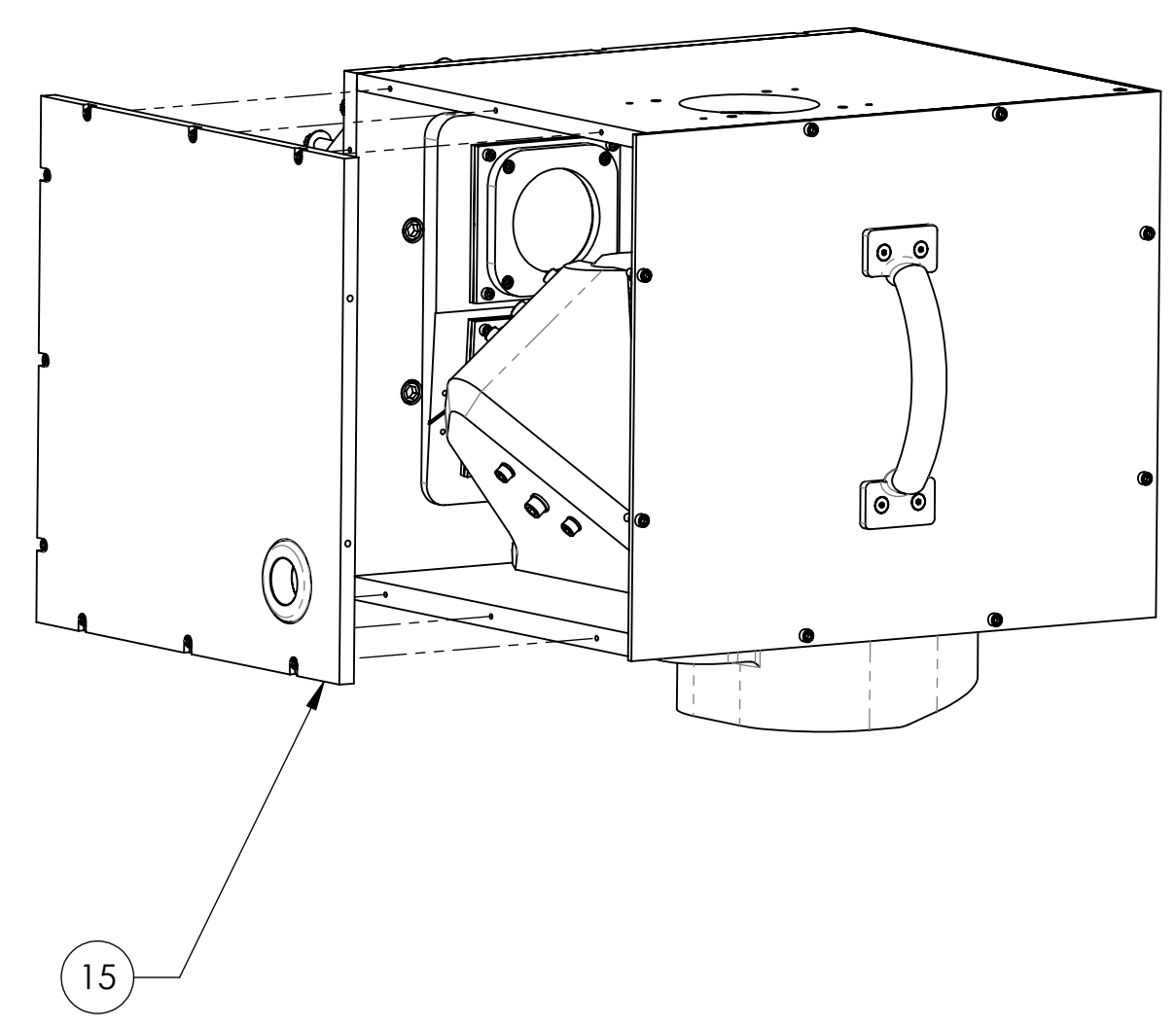
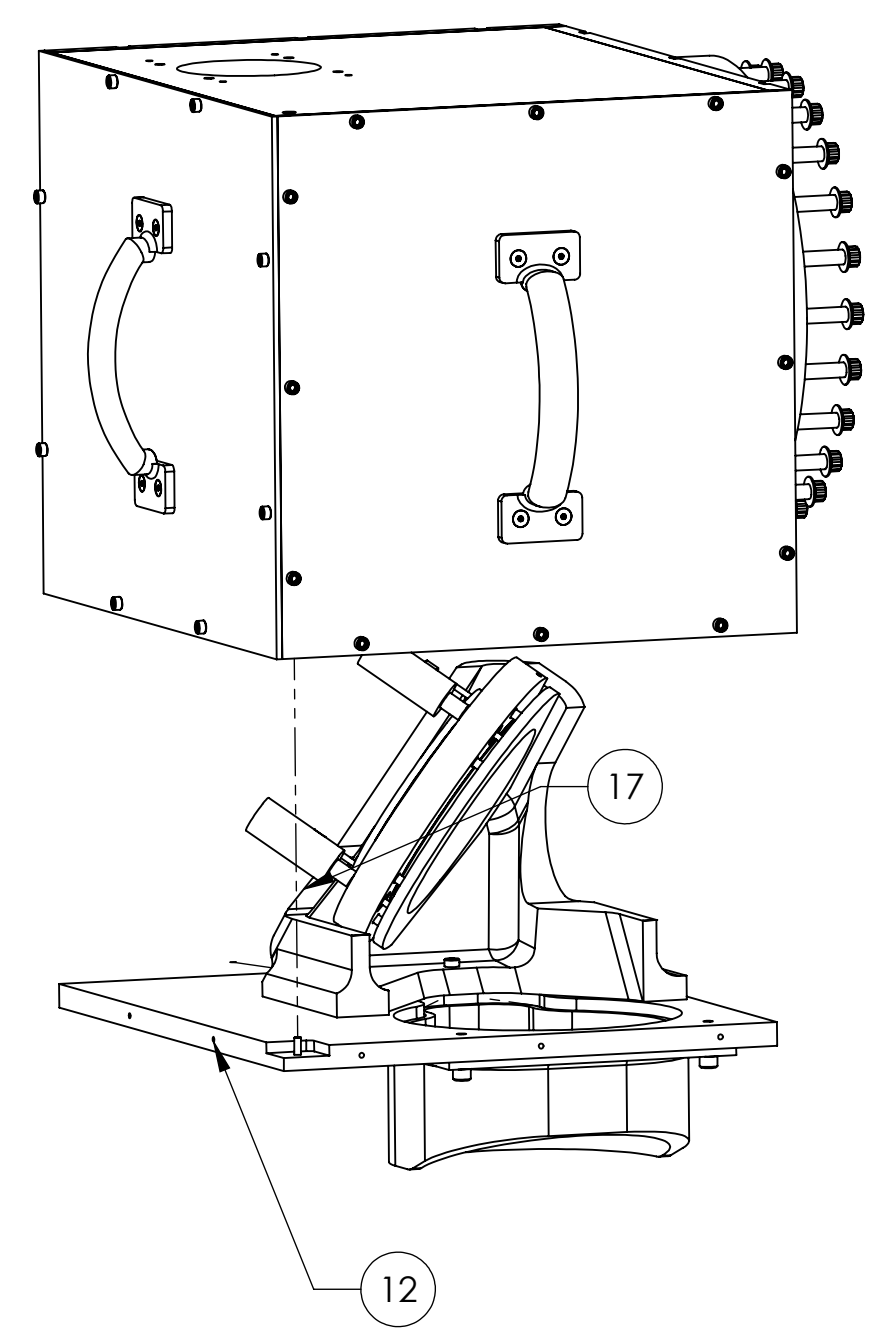
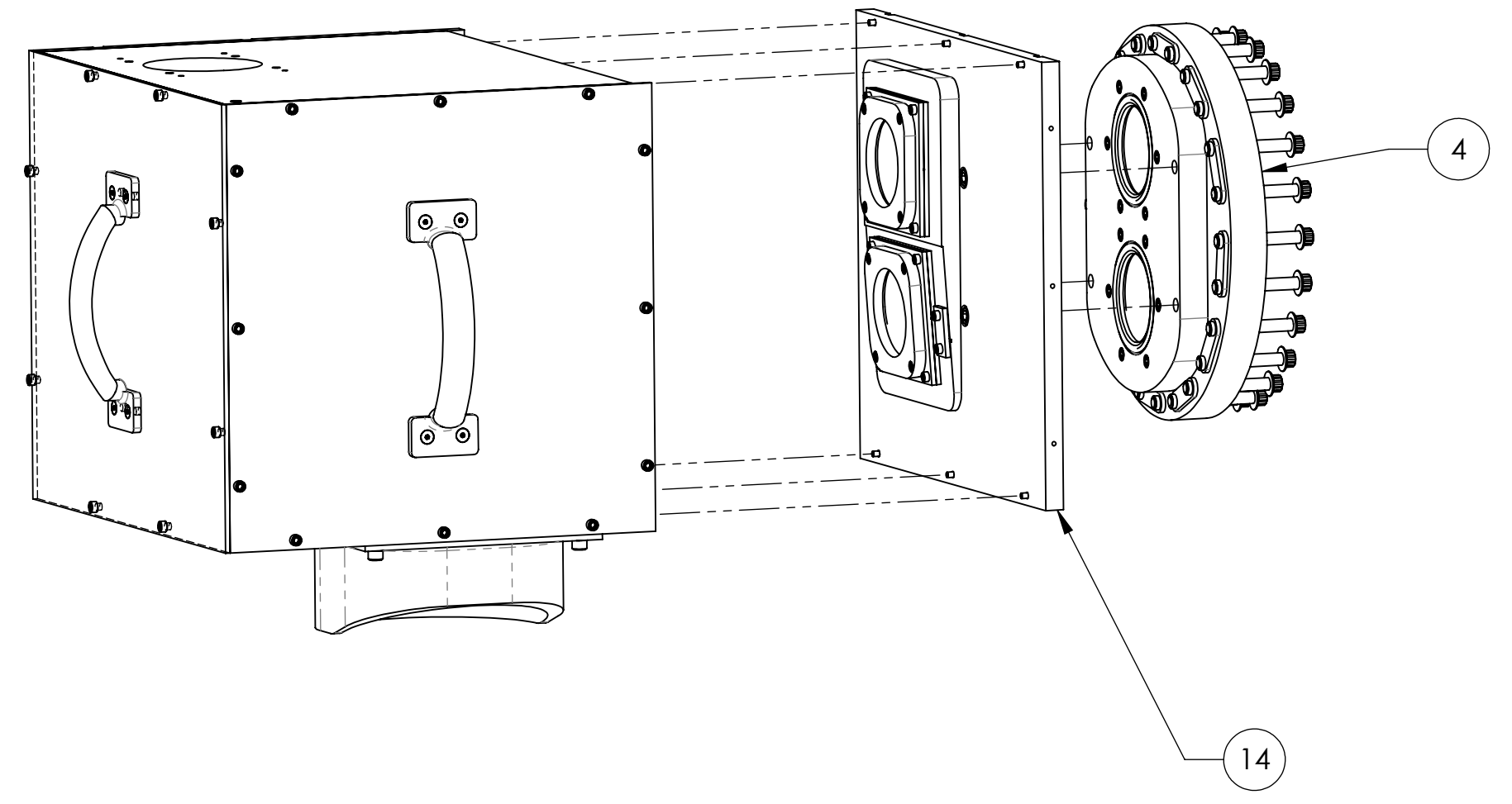
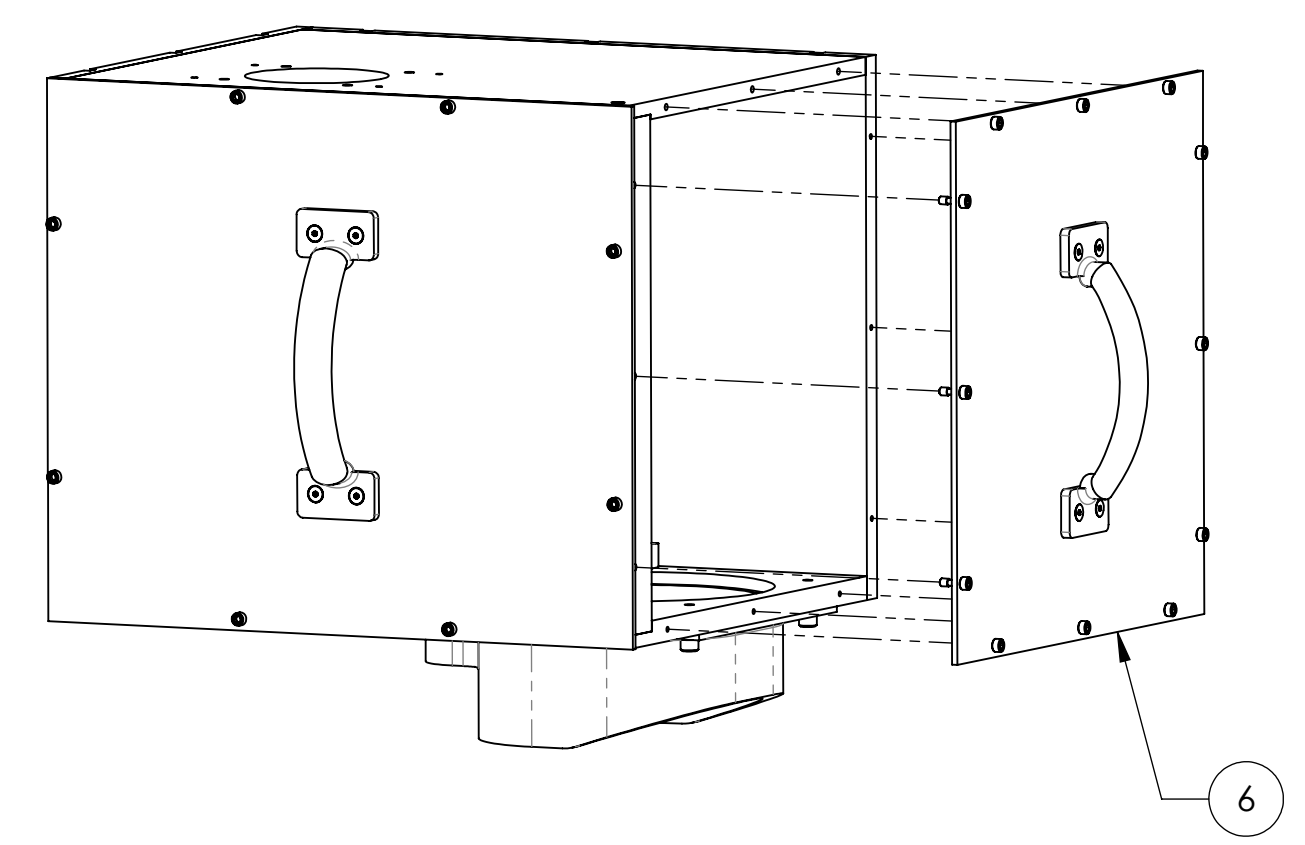

D:\003193_d\UGO TCS Viewport Enclosure Assy. COP. PART PDM REV. X.133. DRAWING PDM REV. X.019

8 7 6 5 4 3 2 1

LIGO CALIFORNIA INSTITUTE OF TECHNOLOGY MASSACHUSETTS INSTITUTE OF TECHNOLOGY		REV.
SIZE DWG. NO.	D1003193	v2
SCALE: 1:4	PROJECTION:	SHEET 2 OF 4

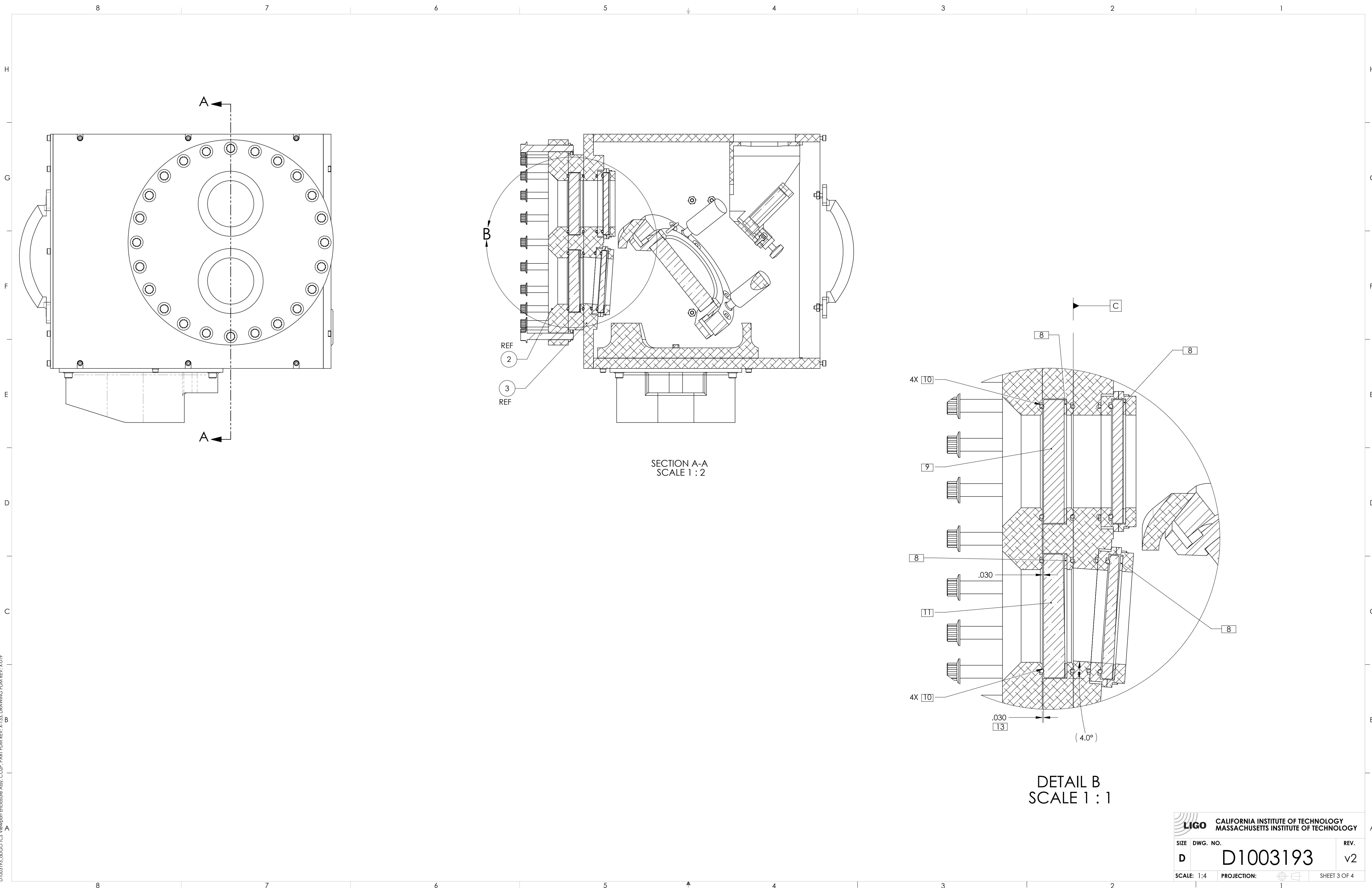

SECTION A-A
SCALE 1 : 2

DETAIL B
SCALE 1 : 1

		CALIFORNIA INSTITUTE OF TECHNOLOGY MASSACHUSETTS INSTITUTE OF TECHNOLOGY	
SIZE	DWG. NO.	REV.	
D	D1003193	v2	
SCALE: 1:4	PROJECTION:	SHEET 3 OF 4	

D1003193.dwg LIGO TCS Viewport Enclosure Assy. COPR. PART PDM REV. X.133. DRAWING PDM REV. X.019

8 7 6 5 4 3 2 1

H
G
F
E
D
C
B
A

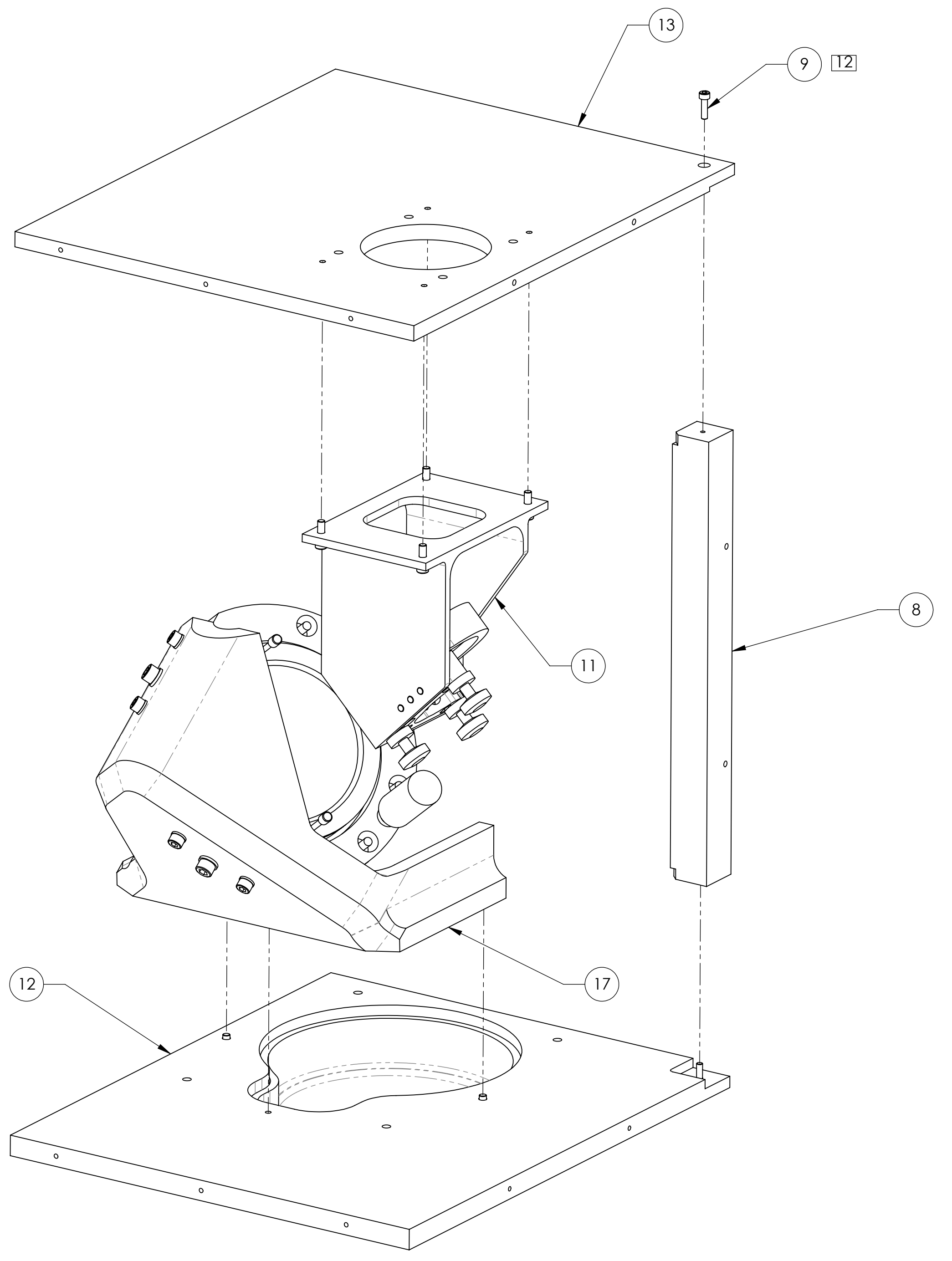

EXPLODED ISO VIEW WITH WALLS HIDDEN
TYPE -01

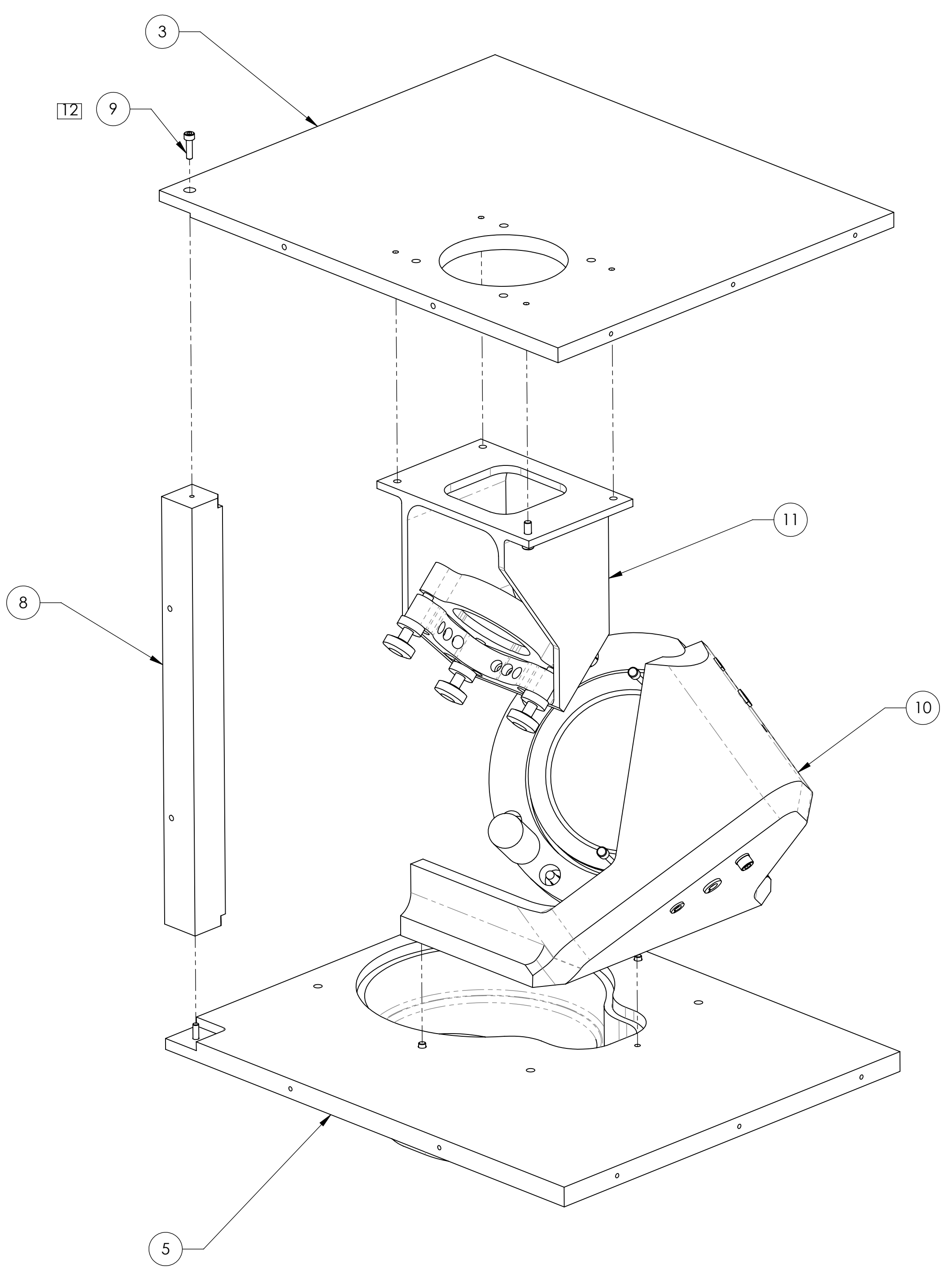

EXPLODED ISO VIEW WITH WALLS HIDDEN
TYPE -02

LIGO CALIFORNIA INSTITUTE OF TECHNOLOGY MASSACHUSETTS INSTITUTE OF TECHNOLOGY		REV.
SIZE	DWG. NO.	REV.
D	D1003193	v2
SCALE: 1:2	PROJECTION:	SHEET 4 OF 4

D:\003193_d\UGO TCS Viewport Enclosure Assy_COPR.PART.PDM.REV.X.133.DRAWING.PDM.REV.X.019