

INITIATOR _____

DATE 7-23-98

1190-898058900-D

ENGINEERING CHANGE REQUEST (ECR)

NEXT ASSEMBLY NO. 972001

CUSTOMER DRAWING NO. 972122

DRAWING TITLE BSC Expansion Bellows

REVISION: FROM E TO F



HYTEC
INCORPORATED

DESCRIPTION OF CHANGE (Simple Phrase, Identify Dims if Possible):

- Change vent slot to reflect actual fab (see attached) ^{OPTIONAL}
- Change Flange tube weldment I.D. & O.D. on Item 3
 I.D. 13.62 now 13.56 (ITEM 3), O.D. 14.02 max now
 13.91 Min Item 3
- Add D.D. Dimension on Dwg 16.500 (3 place)

REASONS FOR CHANGE:

- To match fabrication drawings used @ senior Flexonics

IDENTIFY OTHER PARTS/GROUPS THAT INTERFACE WITH THE ABOVE (Required):

INTERFACE	RESPONSIBLE PARTY	INITIAL
Dr Assembly Tooling	WKM	

NOTIFY COGNIZANT DESIGNER: Roger, Bill K

NOTIFY COGNIZANT ENGINEER: Tim, Eric P.

APPROVED: [Signature]

ATTENTION: TIM THOMPSON @ HYTEC

DWG. NO. A-X

ATTENTION: MIKE FINE @ CALTECH

REVISION HISTORY		
DESCRIPTION	DATE	APPROVED

PHONE: 395-3307 MAIL CODE 18-34

FROM: PETER DRISCOLL

SENIOR FLEXONICS
METAL BELLOWS DIV.
701-704-4105 (F)

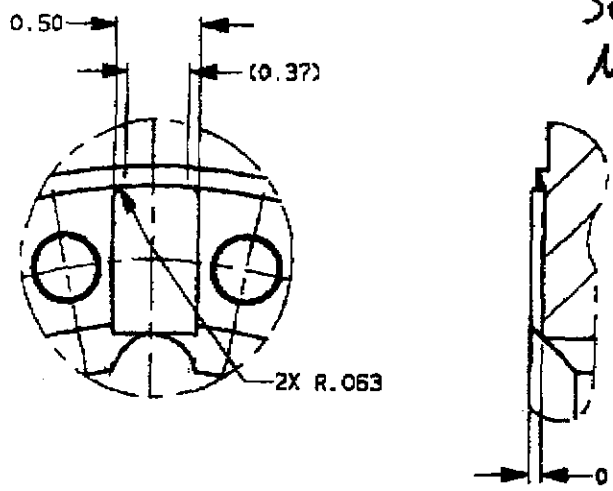

VENT SLOT = .37" X .063"
PD

OPTION 1

(USING Ø.125 END MILL)

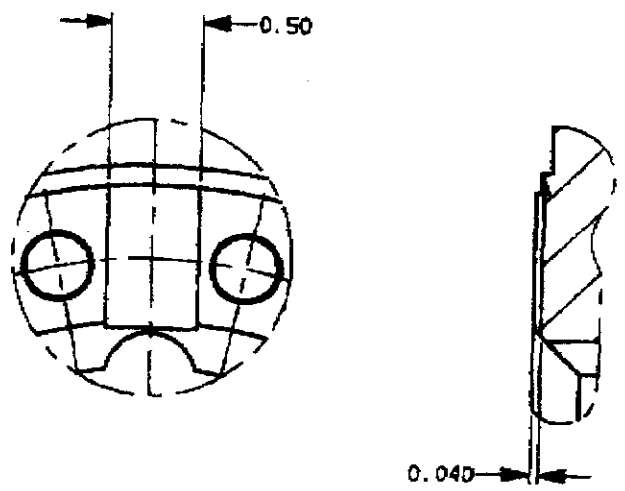

VENT SLOT = .50" X .040"
PD

OPTION 2

(USING Ø.125 END MILL)

REQD	REQD	REQD	REQD	CAGE CODE NO.	DWG SIZE	PART NO.	DESCRIPTION	MATERIAL	SPECIFICATION	IT.

DO NOT USE SULFUR
BASE CUTTING OILS,
ETC.

TOLERANCES UNLESS OTHERWISE SPECIFIED

DECIMALS
.XXX = ± .005 ANGLES ± 1° .005
.XX = ± .010
.X = ± .02

ALL DIMENSIONS ARE IN INCHES
MACHINED SURFACES AND DIAMETERS 125/

BURR FREE PER ES-1018-5
FILLET RADIUS .010 - .020
BREAK CORNERS .005 - .010
INTERPRET DRAWING PER ASME Y14.5M 1994
DRILLED HOLE TOLERANCES PER ANSI Q387
THREADS PER FEDERAL STANDARD H28

DRAWN	DATE	7/23/98
CHK. <i>PD</i>	DATE	7/23/98
ENG. <i>PD</i>	DATE	7/23/98
MFG.		
Q.A.		
MATL SPEC.	304L	AMS-5511
FINISH SPEC.		

SENIOR FLEXONICS INC.
SENIOR FLEXONICS, INC.
METAL BELLOWS DIVISION
1075 PROVIDENCE HIGHWAY
SHARON, MA 02087

SENIOR

TITLE END FITTING			
SIZE A	CAGE CODE 07649	DWG. NO. Mod 47288-100A	REV
SCALE 1/1	SHEET 1 OF 1		

D-47288	73484
NEXT ASSY	JOB REF

07/24/1998 11:17 5056625179 HYTEC PAGE 12