



		IDENTIFICATION			
		H-PORT			
TITLE PUMP PORT "H" HDWR. SPECIFICATION	REFERENCE NO.	SHT 1 OF 5			
	953571	REVISION			
PRODUCT LIGO BEAM TUBE MODULES CALIFORNIA INSTITUTE OF TECHNOLOGY	OFFICE	0-D			
	LIGO	MADE BY	CHKD BY	MADE BY	CHKD BY
		DWD	MLT		
		DATE	DATE	DATE	DATE
		4/18/96	4/19/96		

0.1 SCOPE

This specification is for the supply, welding, fabrication, cleaning, testing, and packaging of shop fabricated pump port hardware for ultra high vacuum service. The pump port hardware is part of a vacuum system for sensitive interferometer components and optical beams for the Laser Interferometer Gravitational-Wave Observatory (LIGO). Field installation will be by the Purchaser.

1.0 APPLICABLE DOCUMENTS

1.1 Drawings / Figures

The following drawing(s) and figure(s) form an integral part of this specification:

Sketch 1 -- Pump Port "H" Hardware.

1.2 Specifications

1.2.1 The vendor shall comply with all applicable sections of the latest edition of the following documents and codes:

ASME Welding Qualifications, Section IX.

ASTM material compliance

Additionally, all supplied components shall be designed and fabricated using sound judgment in accordance with commonly accepted Ultra High Vacuum practice.

1.2.2 In the event of a conflict between the text of this specification (including drawings and figures) and the references listed in Section 1.2.1, the vendor shall immediately notify the Purchaser for resolution.

2.0 MATERIAL SUPPLY

2.1 The vendor shall supply each pump port blind flange with nozzles complete per Sketch 1.

3.0 SUBMITTALS

APPROVED	Information Required with Quotation
<i>M. Jellalain</i>	7-30-96
CBI	DATE
<i>J. Duns</i>	8-12-96
CALTECH	DATE

3.1.1 The vendor shall state in his quotation that "the quotation complies with the technical requirements of the specification". Any exceptions or alternates must be noted and explained. The Purchaser will assume complete conformance unless exceptions are specifically noted.



		IDENTIFICATION			
		H-PORT			
TITLE	PUMP PORT "H" HDWR. SPECIFICATION	REFERENCE NO.		SHT 2 OF 5	
		953571			
PRODUCT	LIGO BEAM TUBE MODULES CALIFORNIA INSTITUTE OF TECHNOLOGY	OFFICE		REVISION	
		LIGO		0-D	
		MADE BY	CHKD BY	MADE BY	CHKD BY
		DWD	MLT		
		DATE	DATE	DATE	DATE
		4/18/96	4/19/96		

3.1.2 Type of forging material used for flanges and nozzles to be supplied.

3.1.3 Thickness of flange.

3.1.4 Fabrication tolerances

3.1.5 Confirmation of flange bolt hole orientations

3.2 Information Required after receipt of Purchase Order

Within 5 working days after receipt of order, the vendor shall submit to the Purchaser:

3.2.1 A description of the vendor's quality assurance manual in accordance with ANSI/ASQC Standard Q91. (Certification is not mandatory).

3.2.2 Helium Mass Spectrometer Leak Test Procedure

3.2.3 Packaging Protection Methods including flange seal surface protection

3.3 Information Required 2 Weeks Prior to Fabrication:

3.3.1 Welding procedures with supporting procedure qualification records and welding personnel qualification records per ASME Section IX.

3.3.2 NDE procedures and qualifications for NDE personnel.

3.4 Information Required Prior to Shipment:

3.4.1 Certificates of Compliance (COC) for all materials.

3.4.2 Documentation of measured helium leakage rates for each pump port flange assembly.

4.0 **MATERIALS**

4.1 Stainless steel conforming to SA240 type 304L.

4.2 Flanges shall be fabricated from forged material and cross rolled.

4.3 Stainless steel tube is preferred to be seamless.

4.4 All welding material shall be ER308L. Flux cored wire is not allowed.



IDENTIFICATION
H-PORT

TITLE PUMP PORT "H" HDWR. SPECIFICATION	REFERENCE NO. 953571		SHT 3 OF 5	
	OFFICE LIGO		REVISION 0-D	
PRODUCT LIGO BEAM TUBE MODULES CALIFORNIA INSTITUTE OF TECHNOLOGY	MADE BY DWD	CHKD BY MLT	MADE BY	CHKD BY
	DATE 4/18/96	DATE 4/19/96	DATE	DATE

4.5 Lubricants that affect the ability to obtain high vacuum levels such as hydrocarbons or silicon shall not be used during fabrication. If a lubricant must be used, the type of lubricant shall be specified and approved by the purchaser before use.

5.0 FABRICATION

5.1 Welding

- 5.1.1 All welding exposed to vacuum shall be done by the gas tungsten arc welding (GTAW) process. The use of flux core wire is strictly prohibited.
- 5.1.2 All welding shall use an inert gas purge on both sides of the weld.
- 5.1.3 All vacuum welds shall be internal and continuous. All external welds added to these for structural purposes shall be intermittent to eliminate trapped volumes.
- 5.1.4 Welding procedures shall be submitted prior to production welding. Weld operator qualification records shall be submitted prior to any individual performing welding. Weld operator qualifications shall comply with Section IX of the ASME Boiler and Pressure Vessel Code. The Purchaser shall have the option to require the re-qualification of any welder at any time if, in the Purchaser's opinion, the welder's qualifications are suspect or welds appear not to be of the proper quality.
- 5.1.5 Weld edge preparation shall be made by machine cutting or grinding. Buming is not permitted.

5.2 Cleanliness and Cleaning

- 5.2.1 All contact made with the stainless steel material during fabrication shall be such as to prevent carbon steel contamination.
- 5.2.2 After fabrication and prior to packaging, the inside surfaces shall be cleaned with a solvent wipe to remove all visible traces of oil and grease. Acetone shall be used first, followed by pure isopropyl alcohol. A detergent and water cleaning mix shall not be used.

5.3 Tolerances

- 5.3.1 Tolerances shall be per the vendor's standard. The vendor's fabrication tolerances shall be submitted to the Purchaser with the quotation (and in response to purchase order).



		IDENTIFICATION			
		H-PORT			
TITLE PUMP PORT "H" HDWR. SPECIFICATION	REFERENCE NO.	SHT 4 OF 5			
	953571				
PRODUCT LIGO BEAM TUBE MODULES CALIFORNIA INSTITUTE OF TECHNOLOGY	OFFICE LIGO		REVISION 0-D		
	MADE BY DWD	CHKD BY MLT	MADE BY	CHKD BY	
	DATE 4/18/96	DATE 4/19/96	DATE	DATE	

6.0 IDENTIFICATION AND TRACEABILITY

Certificates of Compliance (COC) for all materials used in the manufacture of the supplied components are required.

7.0 TESTING AND INSPECTION

- 7.1 The leak testing of the pump port flange assemblies shall be done with a helium mass spectrometer (HMS) using the helium hood technique. The pump port flange assembly HMS test system must be calibrated and the system calibration must indicate that in-leakage of 1×10^{-10} atm. cc/sec. is readily detectable within a reasonable amount of time. The pump port flange assemblies shall not have leakage in excess of 1×10^{-10} atm. cc/sec. The HMS leak test procedure to be used shall be submitted to the Purchaser for approval.
- 7.1 The Purchaser shall have the option of inspecting at the vendor's facility and witnessing tests or procedures required in this specification.
- 7.3 Written notification shall be provided to the Purchaser no less than 5 working days prior to beginning fabrication and also prior to leak testing.
- 7.4 The National Science Foundation (NSF) and Caltech, through their authorized representatives, have the right to inspect and evaluate the work performed or being performed under this specification, including the premises where the work is being performed at all reasonable times. The NSF and Caltech shall have non-escort privileges to all areas of the facilities where the work is being performed under this specification. This shall include access to fabrication, assembly, cleaning, and test areas for the purpose of monitoring activities. The vendor shall furnish all reasonable facilities and assistance for the safe and convenient inspection of the work if requested.

8.0 PACKAGING

It shall be the responsibility of the vendor to protect the pump port flange assemblies during shipment. In particular, the interior of the pump port flange assemblies shall be protected from contamination by sealing all openings. The flange sealing surfaces shall be adequately covered to prevent damage during handling and shipping. In addition, each assembly shall be individually bagged and sealed with plastic wrap. The vendor's method of protecting the pump port flange assemblies shall be submitted to the Purchaser for review with the quotation (and in response to the purchase order).



IDENTIFICATION			
H-PORT			

TITLE PUMP PORT "H" HDWR. SPECIFICATION	REFERENCE NO. 953571		SHT 5 OF 5	
	OFFICE LIGO		REVISION 0-D	
PRODUCT LIGO BEAM TUBE MODULES CALIFORNIA INSTITUTE OF TECHNOLOGY	MADE BY DWD	CHKD BY MLT	MADE BY	CHKD BY
	DATE 4/18/96	DATE 4/19/96	DATE	DATE

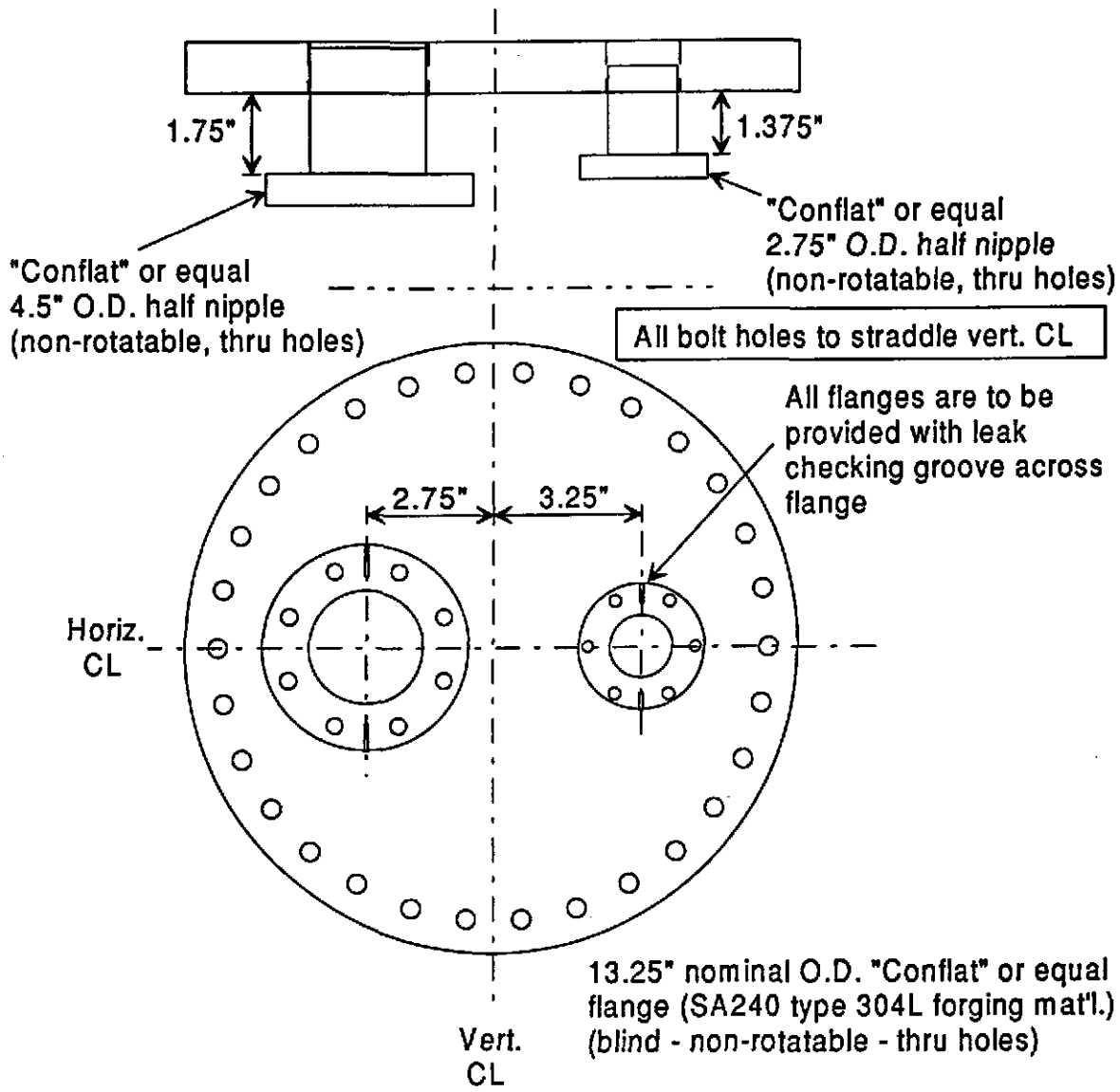

SKETCH 1