

NOTES CONTINUED:
 5. SCRIBE, ENGRAVE, LASER MARK OR MECHANICALLY STAMP (NO DYES OR INKS) A UNIQUE THREE DIGIT SERIAL NUMBER & REVISION NUMBER ON EACH PART. SERIAL NUMBERS START AT 001 FOR THE FIRST ARTICLE AND PROCEED CONSECUTIVELY. BAG AND TAG PARTS WITH THEIR DRAWING PART NUMBER, REVISION, VARIANT OR "TYPE" (IF APPLICABLE), AND QUANTITY. IF PARTS ARE TOO SMALL TO SCRIBE, BAGGING AND TAGGING ALONE IS SUFFICIENT.
 EXAMPLE (PART): 001-v1
 EXAMPLE (TAG): DXXXXXX-VY, TYPE-XX, QTY: TBD

TYPE (CONFIGURATION)	DESCRIPTION
-01	UPPER SEGMENT
-02	LOWER SEGMENT

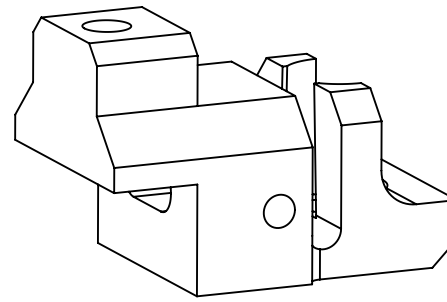

REV.	DATE	DCN #	DRAWING TREE #
v1	13-OCT-2010		
v2	06-NOV-2010	E1000291-v3	E1000295-v4
v3	29-NOV-2010	E1000291-v4	E1000295-v5
v4	06-JAN-2011	E1000291-v5	E1000295-v6
v5	23-SEP-2011	E1100901-v1	E1000295-v8
v6	14 APR 2014	-	E1000295-v8
v7	15 APR 2014	E1400203-x0	E1000295-v8

6. APPROXIMATE WEIGHT = 0.03 LB.
 7. MACHINE ALL SURFACES TO REMOVE OXIDES AND MILL FINISH. USE OF ABRASIVE REMOVAL TECHNIQUES IS NOT ALLOWED.
 8. ALL PARTS SHALL BE MANUFACTURED IN ACCORDANCE WITH LIGO SPECIFICATION E0900364.

TYPE -01

TYPE -02

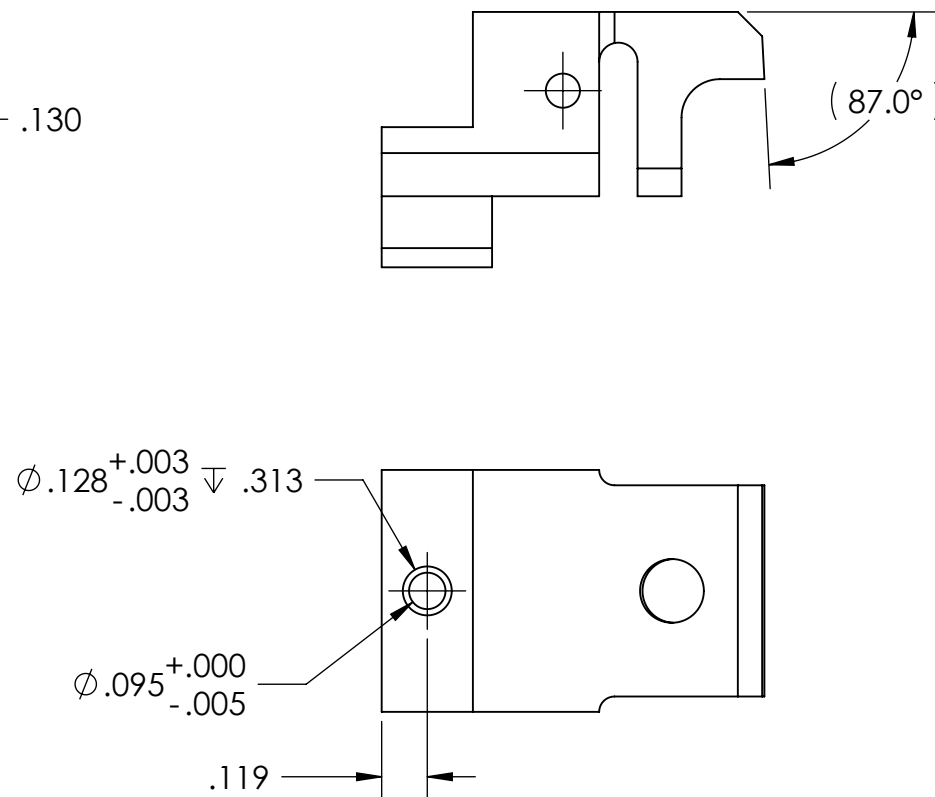
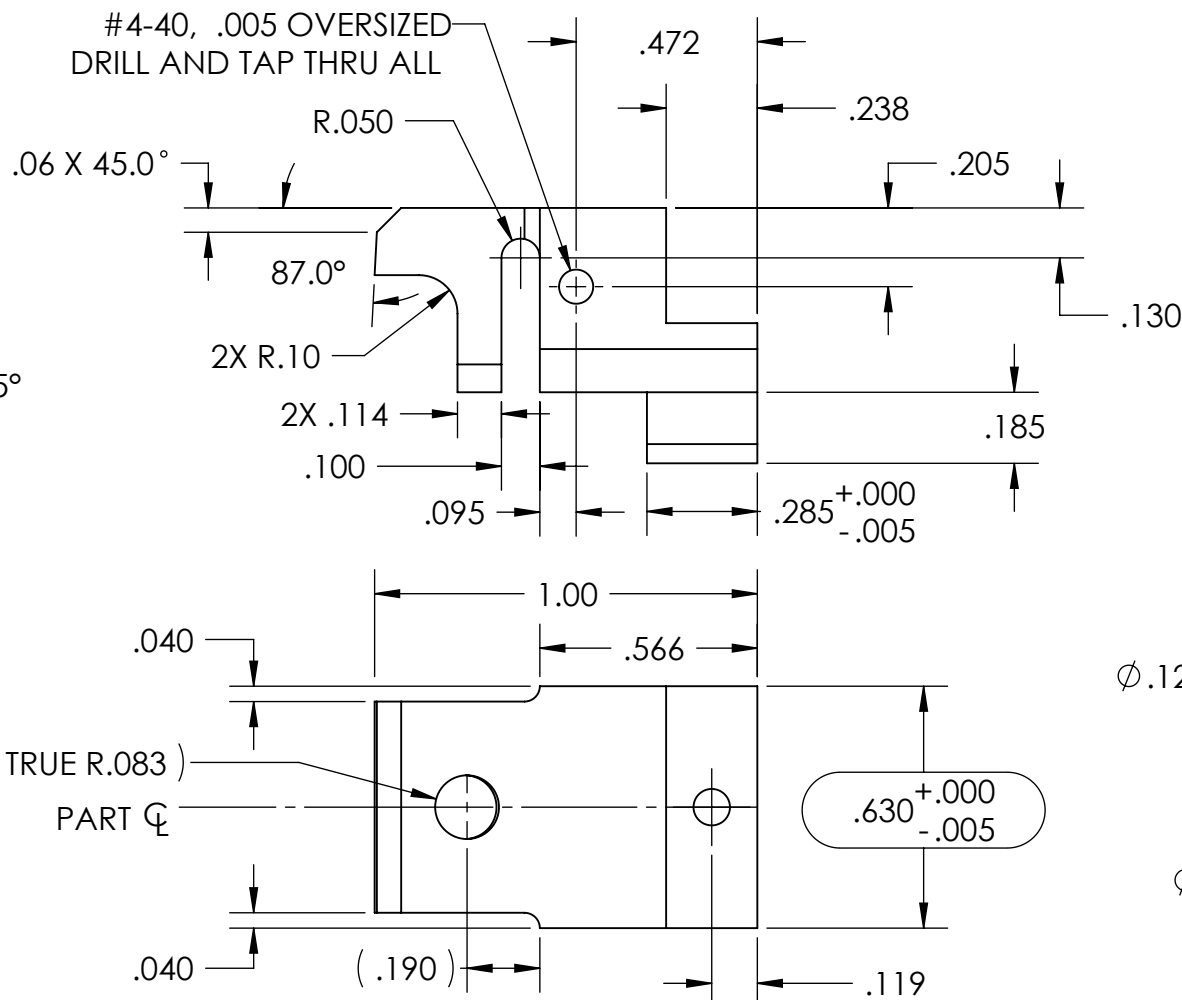
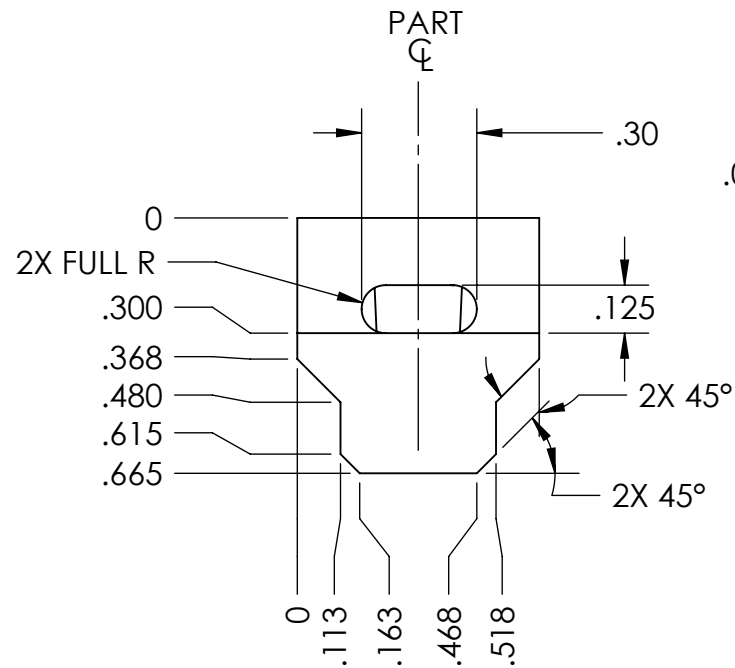
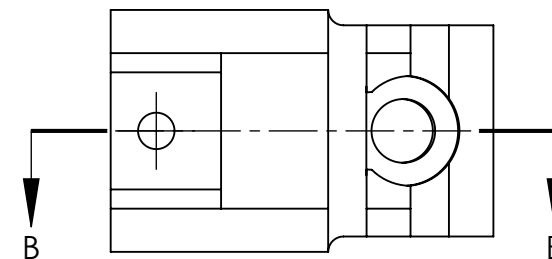
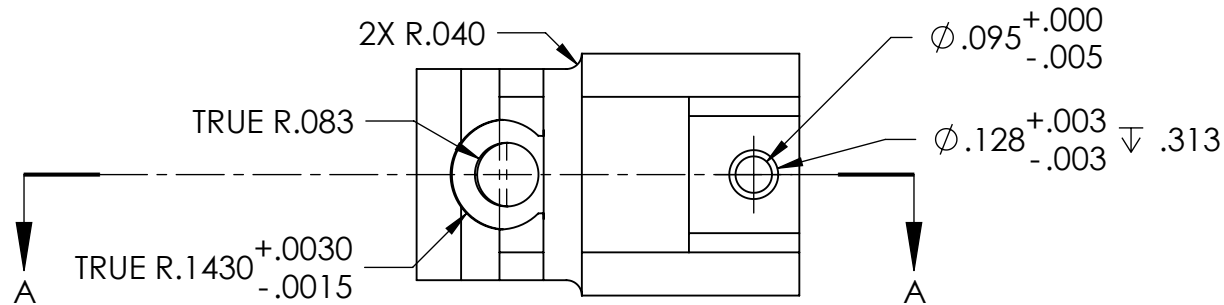

NOTES AND TOLERANCES: (UNLESS OTHERWISE SPECIFIED)
 1. INTERPRET DRAWING PER ASME Y14.5-1994.
 2. REMOVE ALL SHARP EDGES, .02 MAX.
 3. DO NOT SCALE FROM DRAWING.
 4. ALL MACHINING FLUIDS MUST BE FULLY SYNTHETIC, FULLY WATER SOLUBLE AND FREE OF SULFUR, SILICONE, AND CHLORINE.

DIMENSIONS ARE IN INCHES
 TOLERANCES:
 .XX ± .01
 .XXX ± .005
 ANGULAR ± 0.5°

LIGO CALIFORNIA INSTITUTE OF TECHNOLOGY
 MASSACHUSETTS INSTITUTE OF TECHNOLOGY

SYSTEM: **ADVANCED LIGO** SUB-SYSTEM: **AOS**

NEXT ASSY: **D1001838, D1001859**

PART NAME: **RH ELEMENT RETAINER, SIMPLIFIED LEFT**

DESIGNER: M. JACOBSON 01 OCT 2010
 DRAFTER: M. JACOBSON 01 OCT 2010
 CHECKER: J. LEWIS 06 JAN 2011
 APPROVAL: A. BROOKS 23 SEP 2011

SIZE: **B** DWG. NO.: **D1002543** REV.: **v7**

SCALE: 2:1 PROJECTION: SHEET 1 OF 2

D1002543_RH ELEMENT RETAINER, SIMPLIFIED LEFT, PART PDM REV: X-040, DRAWING PDM REV: X-032

8 7 6 5 4 3 2 1

D
C
B
A

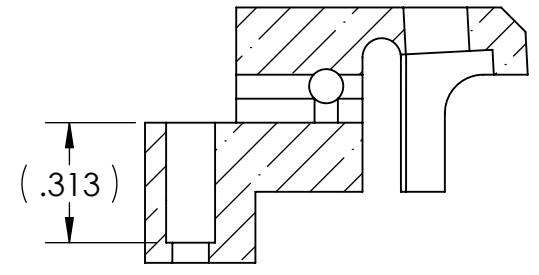
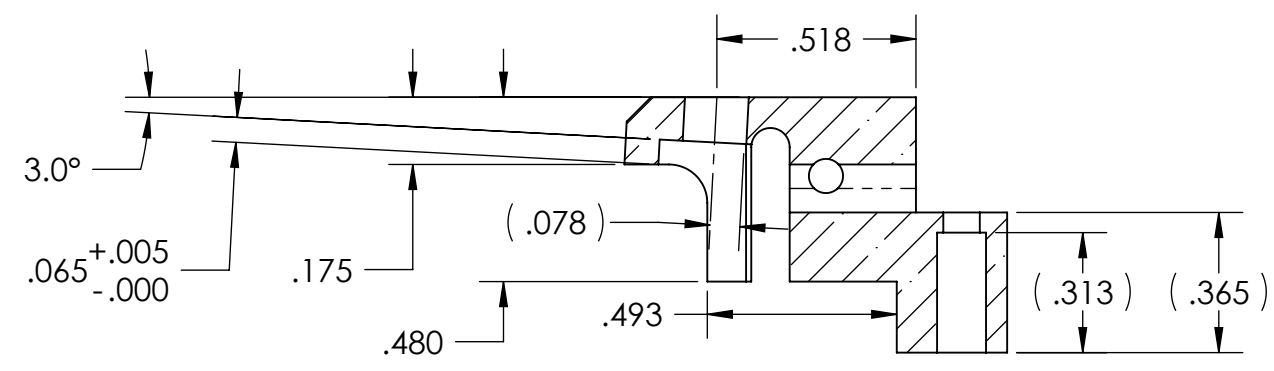

LIGO CALIFORNIA INSTITUTE OF TECHNOLOGY
MASSACHUSETTS INSTITUTE OF TECHNOLOGY

SIZE	DWG. NO.	REV.
B	D1002543	v7
SCALE: 2:1		PROJECTION:
		SHEET 2 OF 2

8 7 6 5 4 3 2 1

D
C
B
A