

NOTES: (UNLESS OTHERWISE SPECIFIED)

- CUTTING FLUIDS TO BE WATER SOLUBLE AND FREE OF SULFUR, CHLORINE, & SILICONE.

△ STEEL STAMP OR ENGRAVE THE DRAWING PART NUMBER ON NOTED FACE OF PART FOLLOWED BY "S/N", THEN A THREE DIGIT SERIAL NUMBER. SERIAL NUMBERS TO START AT 001 FOR FIRST PART AND PROCEED IN A CONSECUTIVE MANNER TO A MAXIMUM OF 999, FOR EACH SUCCEEDING PART PRODUCED. USE 0.13 HIGH CHARACTERS.
EXAMPLE: D990038-A S/N 001

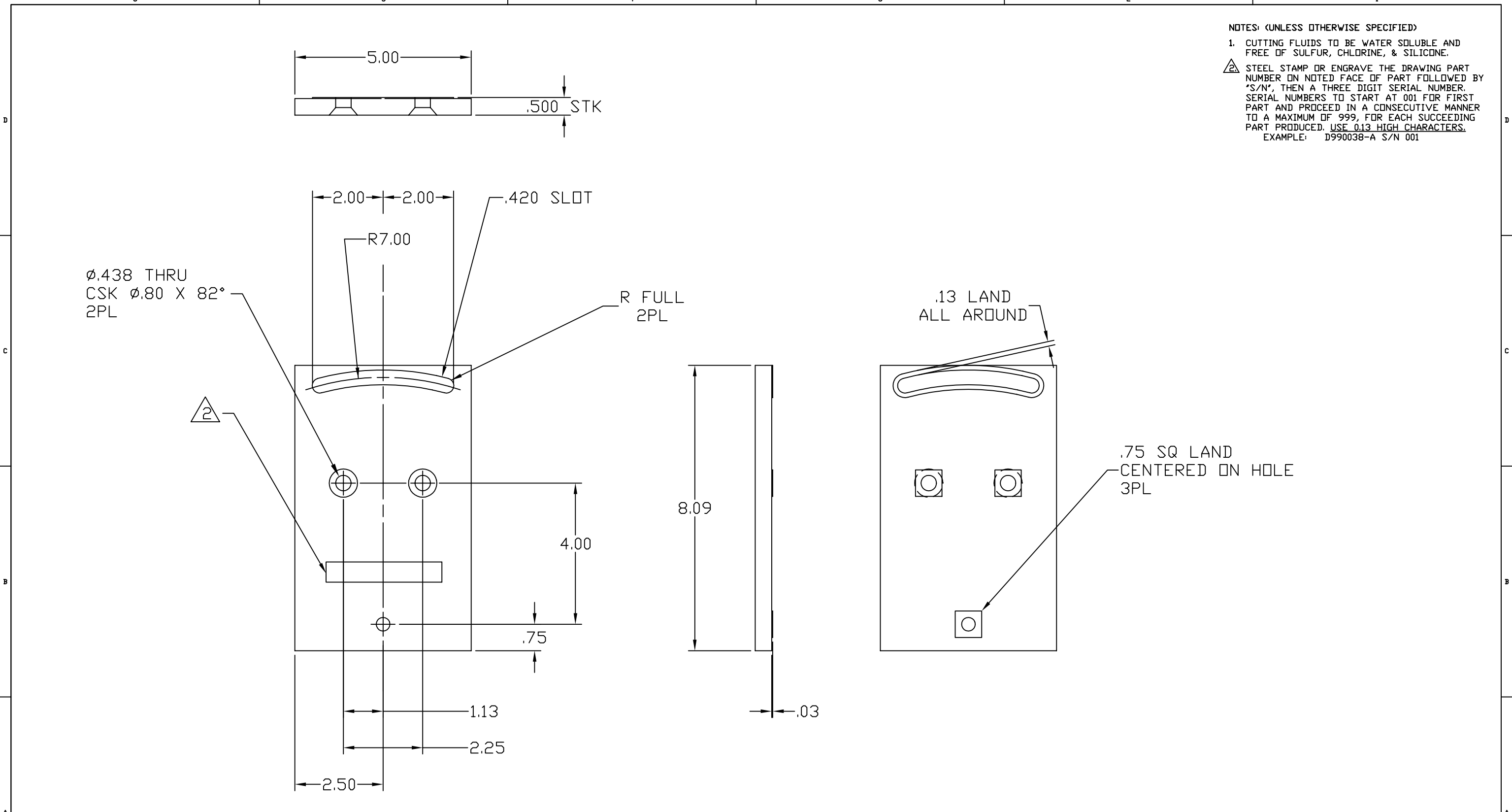

		UNLESS OTHERWISE SPECIFIED DIMENSIONS ARE IN INCHES								LIGO CALIFORNIA INSTITUTE OF TECHNOLOGY MASSACHUSETTS INSTITUTE OF TECHNOLOGY	
		TOLERANCES: FRACTIONAL ± ANGULAR ± ANGULAR MACH ± BEND ± TWO PLACE DECIMAL ±.01		THREE PLACE DECIMAL ±.005 FINISHED SURFACE RMS BREAK CORNERS IN: OUT: .005-.010 REMOVE ALL BURRS						CAVITY BEAM DUMP HOUSING PLATE	
		MATERIAL: 6061-T6 ALU PLATE .500" THICK		HEAT TREAT:		FINISH:		REV		CAD FILE	
DWG. NO.		DESCRIPTION		USED ON:		NEXT ASS'Y: D990141		REV		D990140-B.dwg	
REFERENCE DRAWINGS								DESCRIPTION		SIZE DWG. NO.	
								APPR'D CHECK DRWN DATE		B D990140-B	
								SCALE		SHEET	
								NTS		1 OF 1	