

NOTES: (UNLESS OTHERWISE SPECIFIED)

Liquid contaminants/Machining Lubricants
 Liquids containing hydrocarbons or other contaminants, other than the machining fluids specified herein, shall not be allowed to come into contact with suspension material at any time. All machining fluids shall be water soluble and free of sulfur, chlorine and silicone; such as Cincinnati Milacron's Cimtech 410 (stainless steel).

Identification Serial Number
 A serial number shall be etched, or scribed on the part see note drawing note.

Serial Number Format
 The Serial number shall be of the format: D99xxxx-x-001

Example: D990021-A-001
 The drawing number, The revision number, The sequential part number

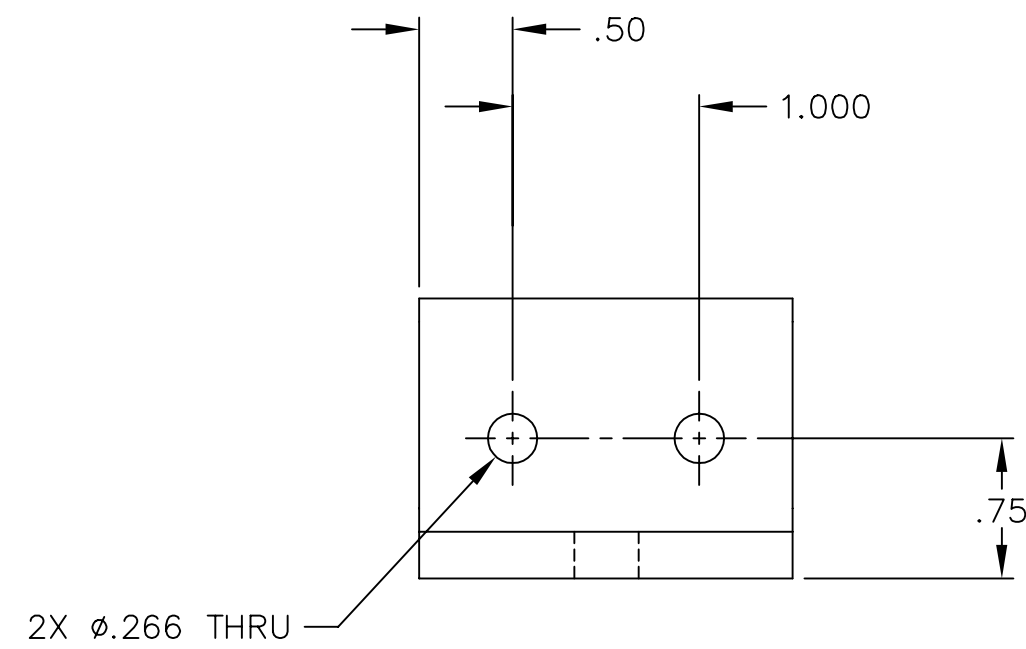
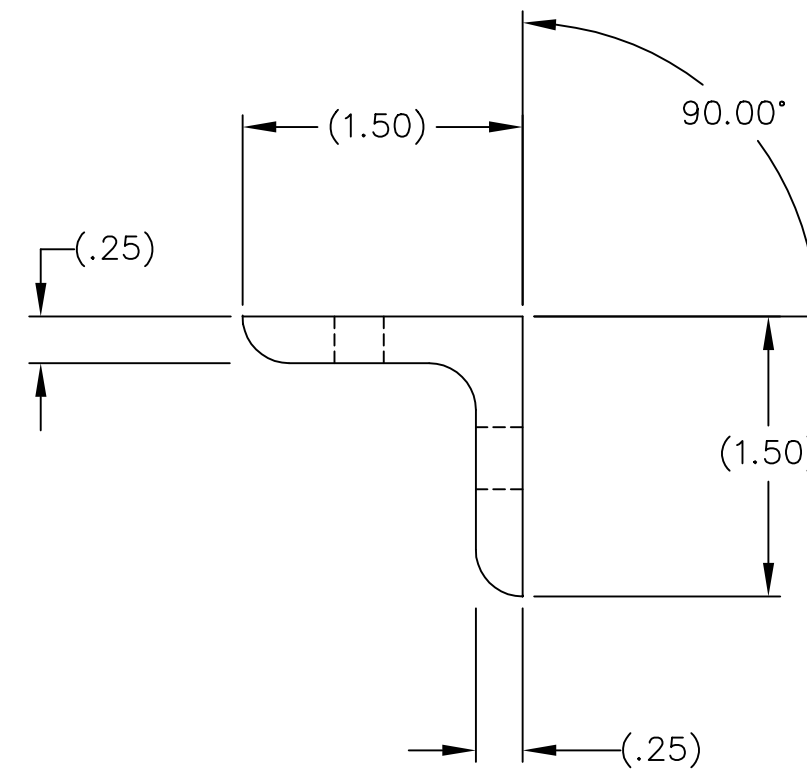
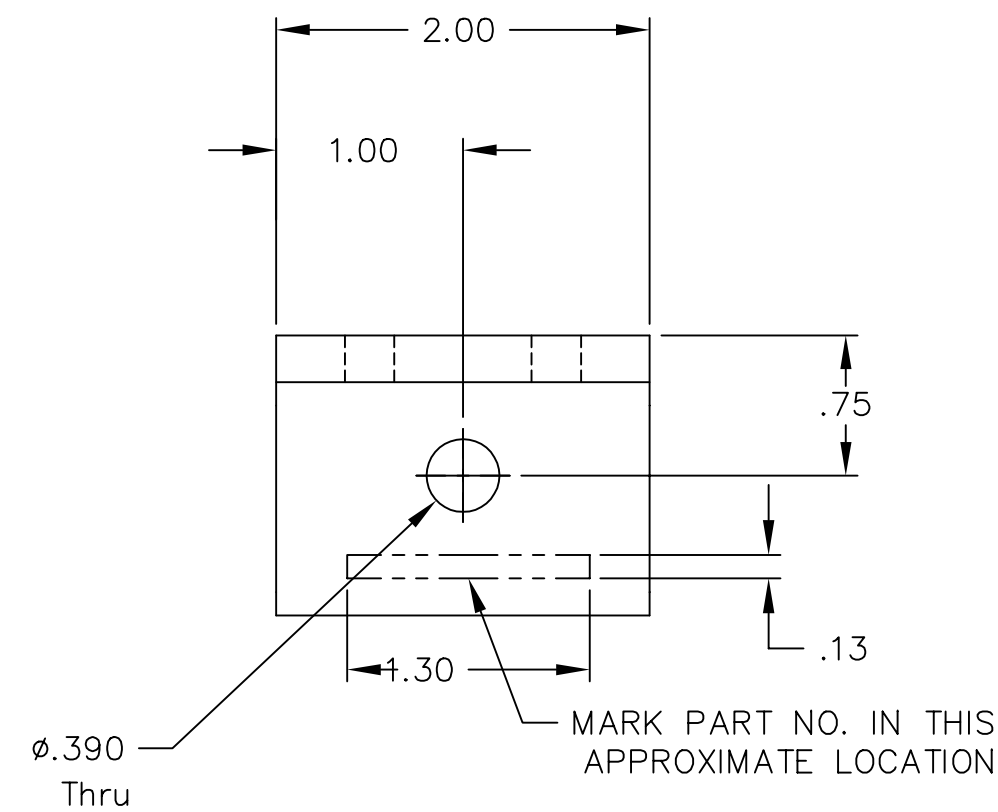

ref. 1 per assembly

REF	QTY	PART or DRWG No.	DESCRIPTION	MATERIAL
PARTS and MATERIAL LIST				
LIGO CALIFORNIA INSTITUTE OF TECHNOLOGY MASSACHUSETTS INSTITUTE OF TECHNOLOGY				
ANGLE, ETM ADJUSTING				
B		FOR FABRICATION	kenm	4-22-99
00		PRE-RELEASE	-	CHAPUT 11-3-98
REV		DESCRIPTION	DCN NUMBER	APPR'D CHECK DRWN DATE
SCALE				1 : 1
SHEET				1 OF 1

UNLESS OTHERWISE SPECIFIED DIMENSIONS ARE IN FEET (cm)		
TOLERANCES: FRACTIONAL ± 1/16 ANGULAR ± .25° ANGULAR MACH ± .001 TWO PLACE DECIMAL ± .01	THREE PLACE DECIMAL ± .005 FINISHED SURFACE RMS 6.3 BREAK CORNERS IN: .015 OUT: .015 REMOVE ALL BURRS	
MATERIAL: 1.5 X 1.5 X .25 THK. 6061 T-6 ALUM. Angle	HEAT TREAT: /	FINISH: /
USED ON: XXX	NEXT ASS'Y: XXX	

XXX	XXX
DWG. NO.	DESCRIPTION
REFERENCE DRAWINGS	

6

5

4

3

2

1