

- NOTES: (UNLESS OTHERWISE SPECIFIED)
- 1. STAMP OR ENGRAVE SERIAL NUMBER ON NOTED FACE OF PART PER LIGO L970196.
 - 2. ALL MACHINING FLUIDS SHALL BE WATER SOLUBLE AND FREE OF SULFUR, CHLORINE, AND SILICONE.

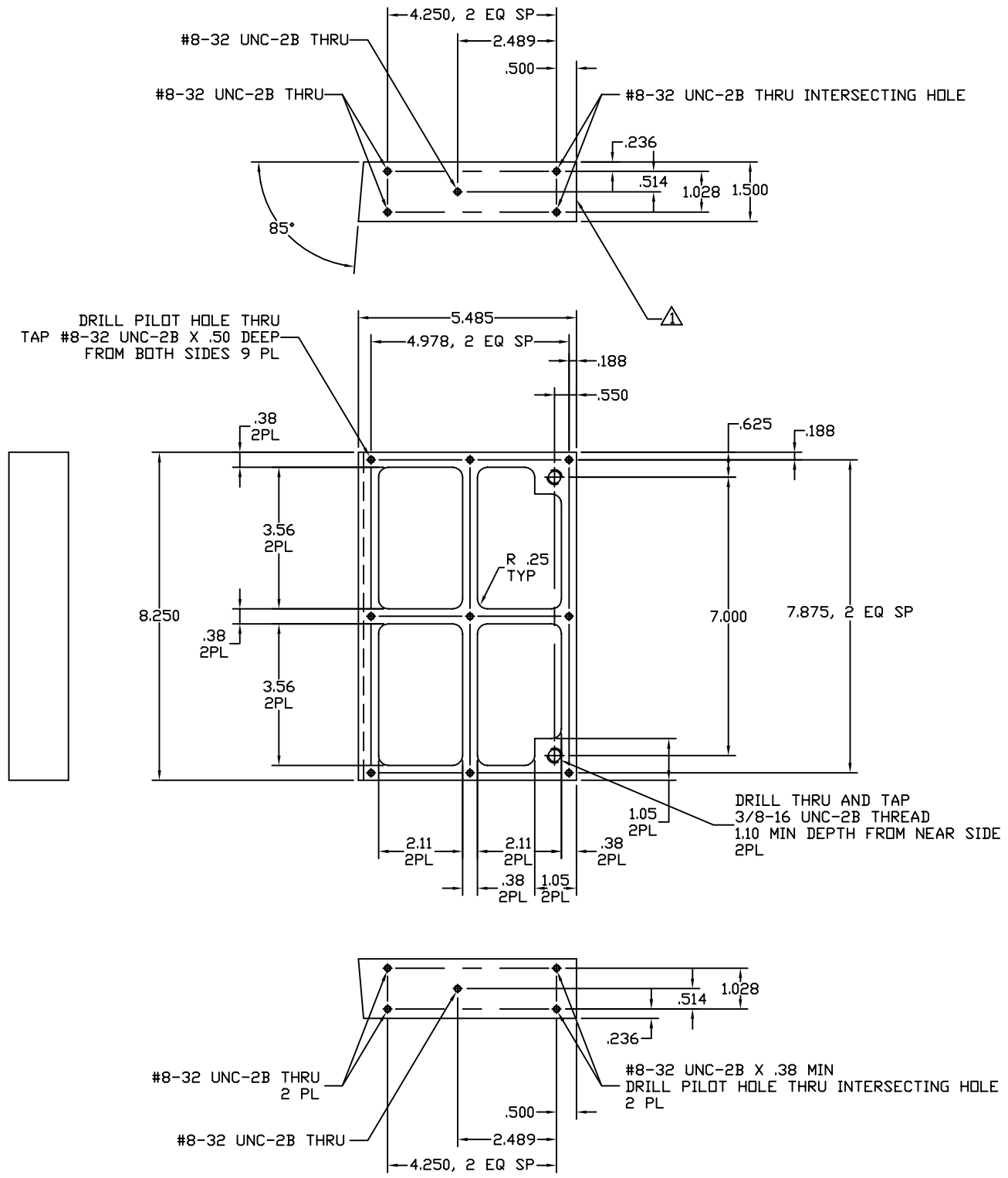

		UNLESS OTHERWISE SPECIFIED DIMENSIONS ARE IN INCHES							LIGO CALIFORNIA INSTITUTE OF TECHNOLOGY MASSACHUSETTS INSTITUTE OF TECHNOLOGY			
		TOLERANCES: FRACTIONAL ± ANGULAR ± ANGULAR MACH ± BEND ± TWO PLACE DECIMAL ±.01		THREE PLACE DECIMAL ±.005 FINISHED SURFACE RMS BREAK CORNERS IN: .005-.010 REMOVE ALL BURRS						CAVITY BEAM DUMP STIFFENER BLOCK		
		MATERIAL: 6061-T6 ALU	HEAT TREAT:	FINISH:	A	DCN E990108		Conley	1-2-99	CAD FILE D980378-Adwg	SIZE DWG. NO. B D980378-A	
DWG. NO.	DESCRIPTION	USED ON:	NEXT ASS'Y:		REV	DESCRIPTION	APPR'D	CHECK	DRWN	DATE	SCALE	SHEET
	REFERENCE DRAWINGS		D990094			ISSUE DESCRIPTION					NTS	1 OF 1