

NOTES:

- 1) CONTRACTOR SHALL ANCHOR TRANSFORMER BOX PAD ITEM #031 TO ASPHALT SURFACE WITH (8) 1/2" MIN. DIA. ANCHORS. IF TRANSFORMER IS INSTALLED ON GRAVEL SURFACE SUBSTITUTE (8) 1/2" X 16" STEEL STAKES FOR ITEM #033.
- 2) CONTRACTOR SHALL SUPPLY AND INSTALL TRANSFORMER BOX PAD ITEM #031 WITH COVER ITEM #032.
- 3) CONTRACTOR SHALL SUPPLY AND INSTALL ADHESIVE REFLECTIVE TAPE ON ALL SIDES OF BOX 2" BELOW TOP.

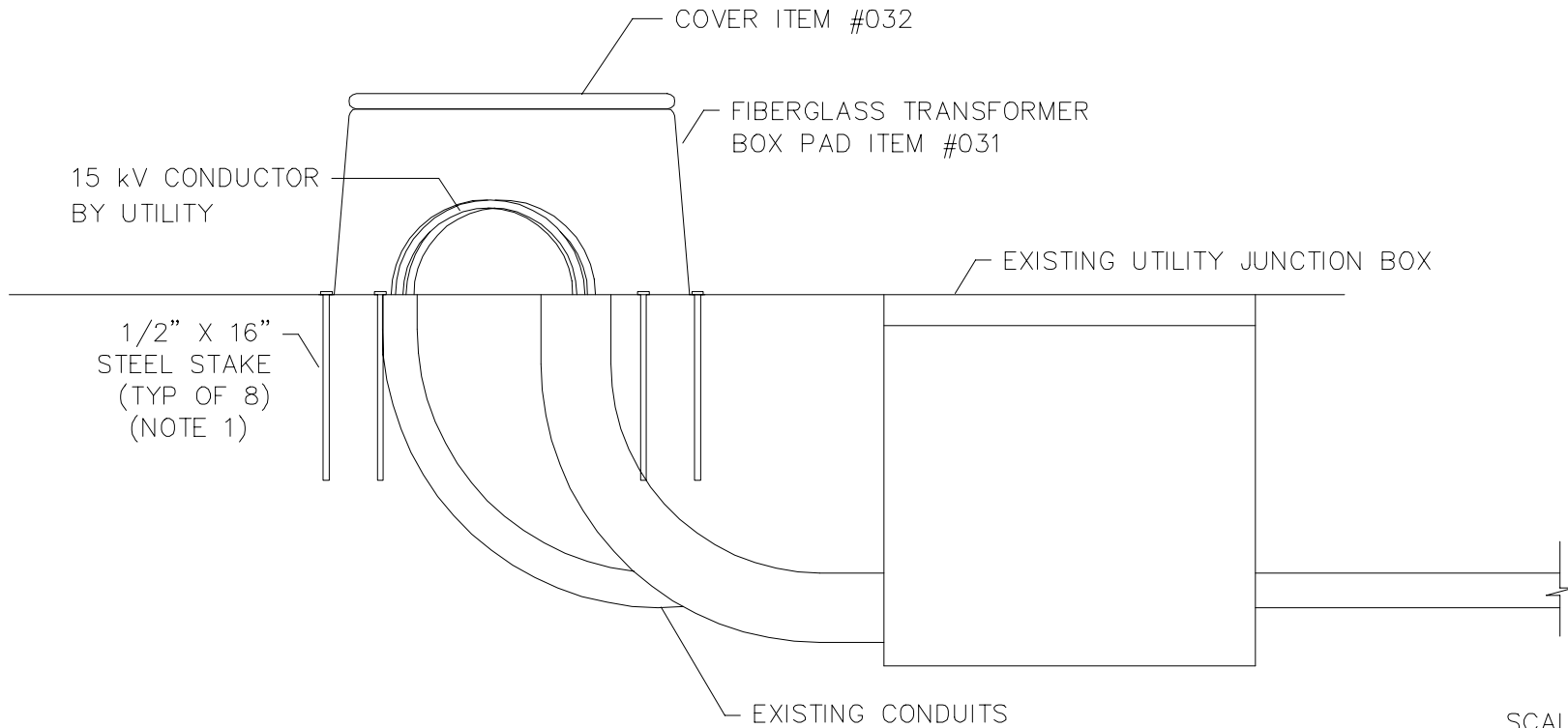
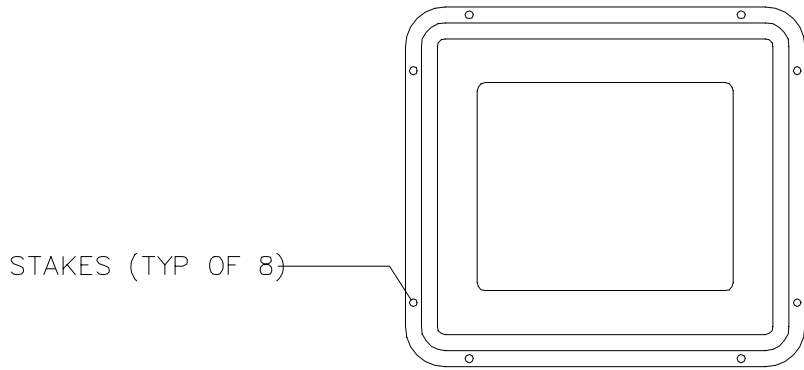

SCALE: 1/2"=1'0"