

8 7 6 5 4 3 2 1

REVISIONS			
REV.	DESCRIPTION	DATE	APPROVED
A	REVISED PAINT SPEC.	3-13-98	WKM

D

D

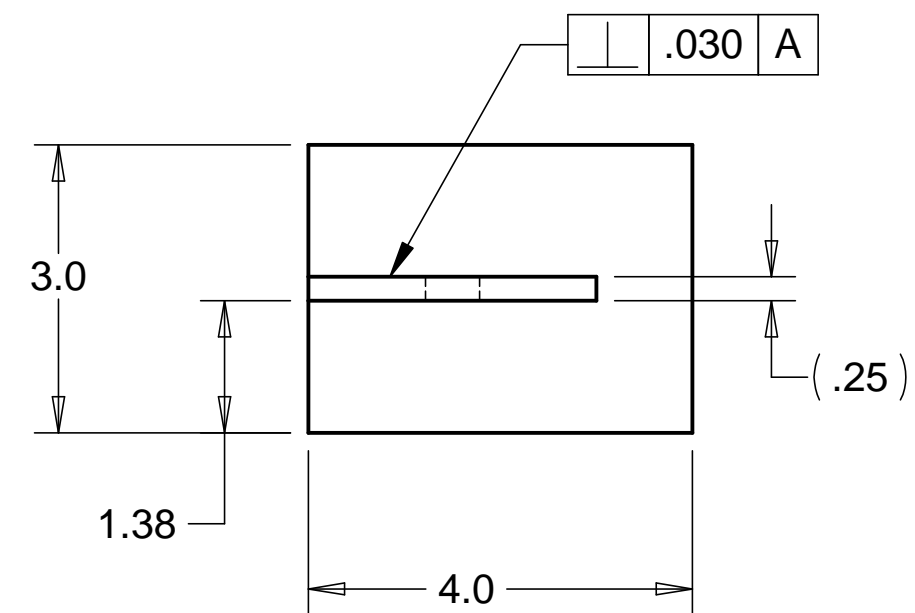

C

C

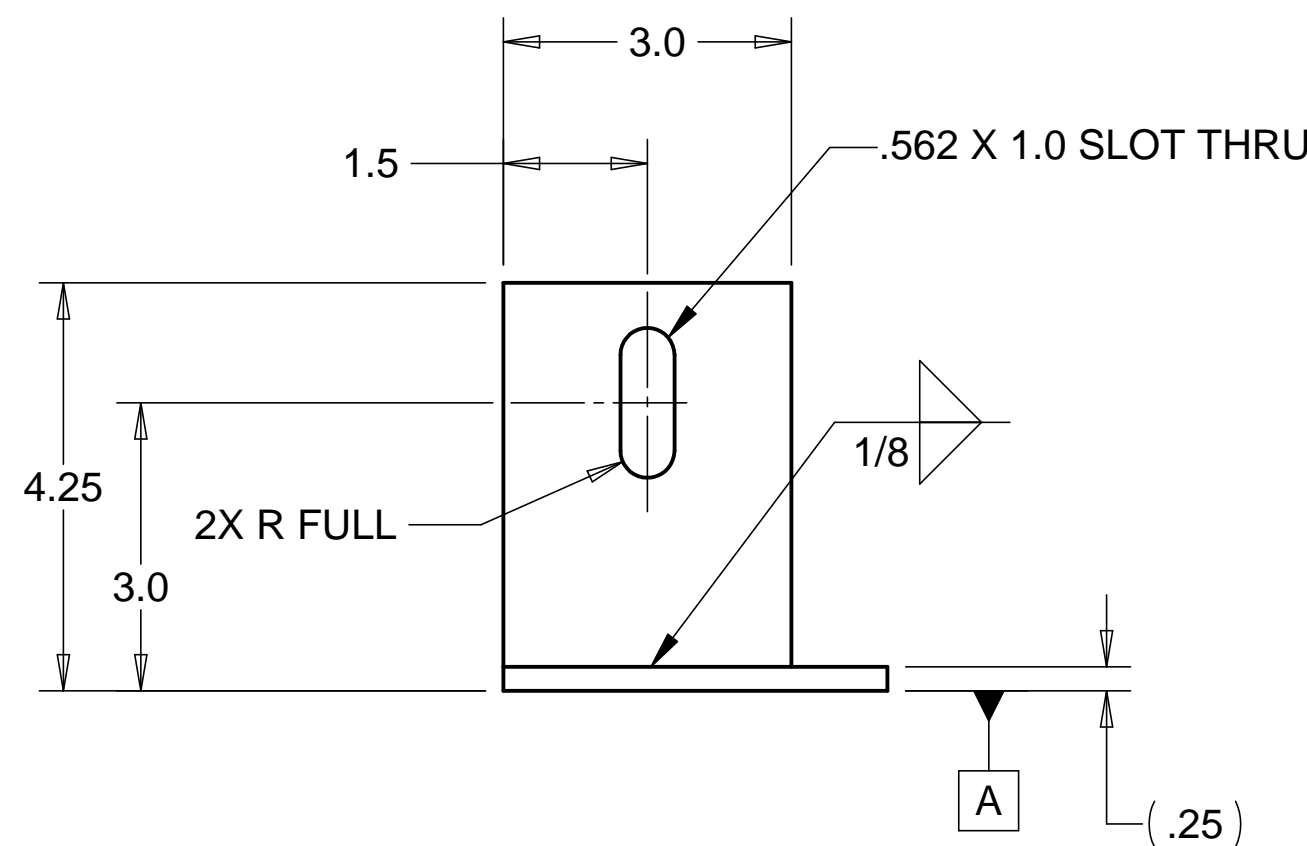

B

B

MATL: 1/4" THK A36 STEEL

NOTES: UNLESS OTHERWISE SPECIFIED

1. ALL DIMENSIONS IN INCHES
2. DIMENSIONS AND TOLERANCING PER ASME Y14.5M-1994
3. SURFACE TEXTURE PER ANSI/ASME B 46.1-1985
4. REMOVE ALL BURRS AND BREAK SHARP EDGES TO A MAXIMUM OF .015
5. ALL INSIDE CORNERS TO BE .015 RADIUS MAX
6. COUNTERSINK 82 DEGREES ALL TAPPED HOLES TO MAJOR DIAMETER
7. COUNTERSINK 82 DEGREES APPROXIMATELY .015 DEEP ALL DRILLED HOLES
8. PARTS TO BE THOROUGHLY CLEANED TO REMOVE ALL OIL, GREASE, DIRT AND CHIPS
9. PART NUMBER (DRAWING NO. PLUS DASH NO. PLUS SERIAL NO. ) TO BE CLEARLY MARKED ON THE PART ITSELF.
10. PART WEIGHS 2 Lbs.

- △ 11. PRIMER (ALL VISIBLE SURFACES): SHERMAN WILLIAMS INDUSTRIAL WASH PRIMER PG062.
- △ 12. PAINT (ALL VISIBLE SURFACES): SHERMAN WILLIAMS POLANE T POLYURETHANE COLOR JUNCTION YELLOW, COLOR #F63TXY-0310-4352.

A

A

8 7 6 5 4 3 2 1

PARTS LIST			
UNLESS OTHERWISE SPECIFIED: DIMENSIONS ARE IN INCHES -TOLERANCES-	CAD GENERATED DRAWING, DO NOT MANUALLY UPDATE DO NOT SCALE DRAWING		<b>HYTEC, INC</b> TITLE <b>HAM ROLLER SYSTEM FOOT WELDMENT</b>
	DECIMALS X = +/- .1 .XX = +/- .060	ANGULAR = +/- .30' SURFACE FINISH = 250	
FINISH	SIGNATURE	DATE	SCALE <b>1/2</b> REVISION <b>A</b>
PART NO. <b>D972932-1</b>	DESIGNED	W. K. MILLER	12/12/97
	DRAWN	W. K. MILLER	12/12/97
	CHECKED	HARRY SALAZAR	2/3/98
	ENGR.	T. THOMPSON	2/3/98
	APPROVED	T. THOMPSON	2/3/98