

8 7 6 5 4 3 2 1

REVISIONS			
REV.	DESCRIPTION	DATE	APPROVED
A	ADJUSTED WELD SYMBOL, PAINT SPECIFICATION	3/13/98	WKM

D

D

C

C

B

B

A

A

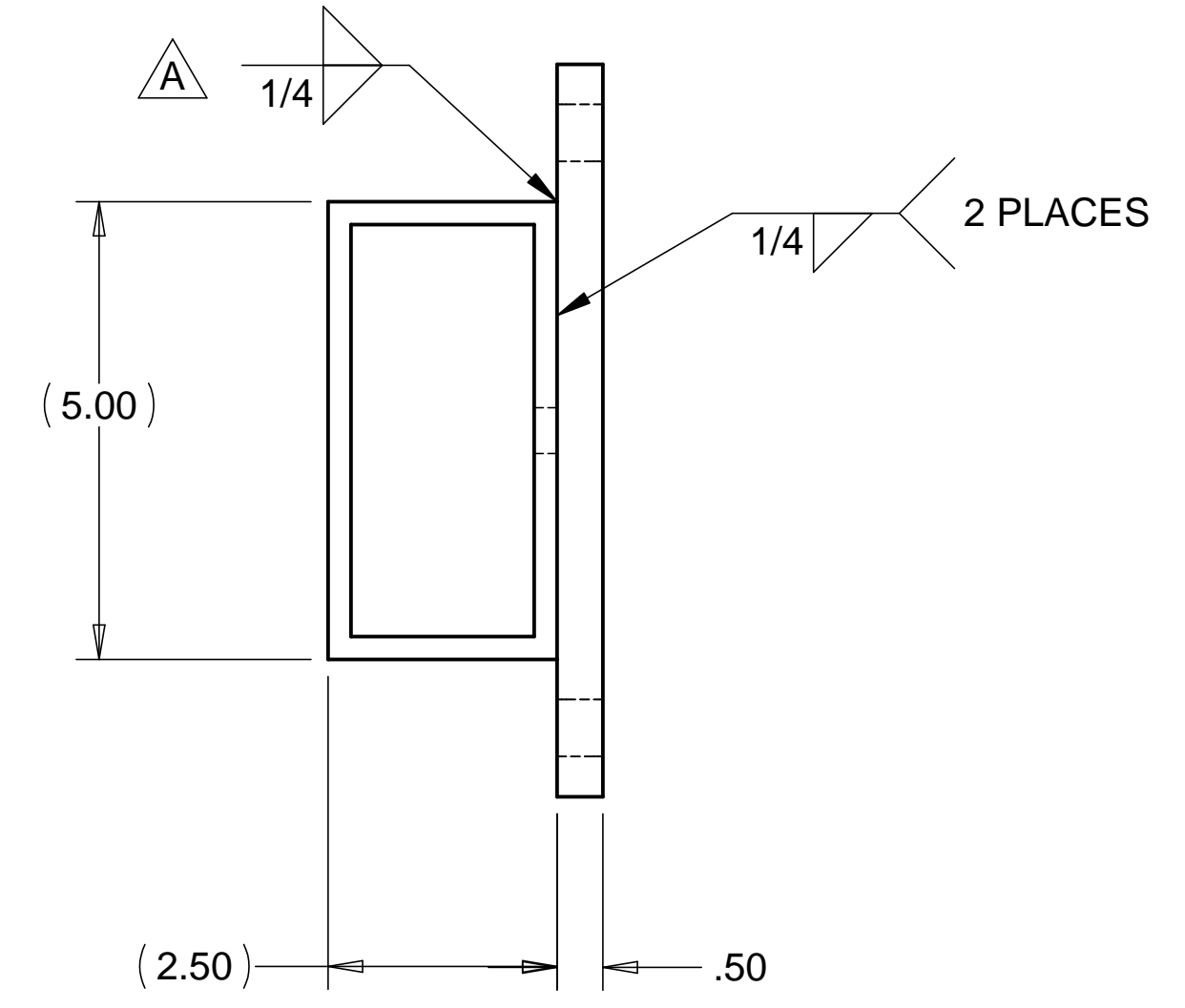
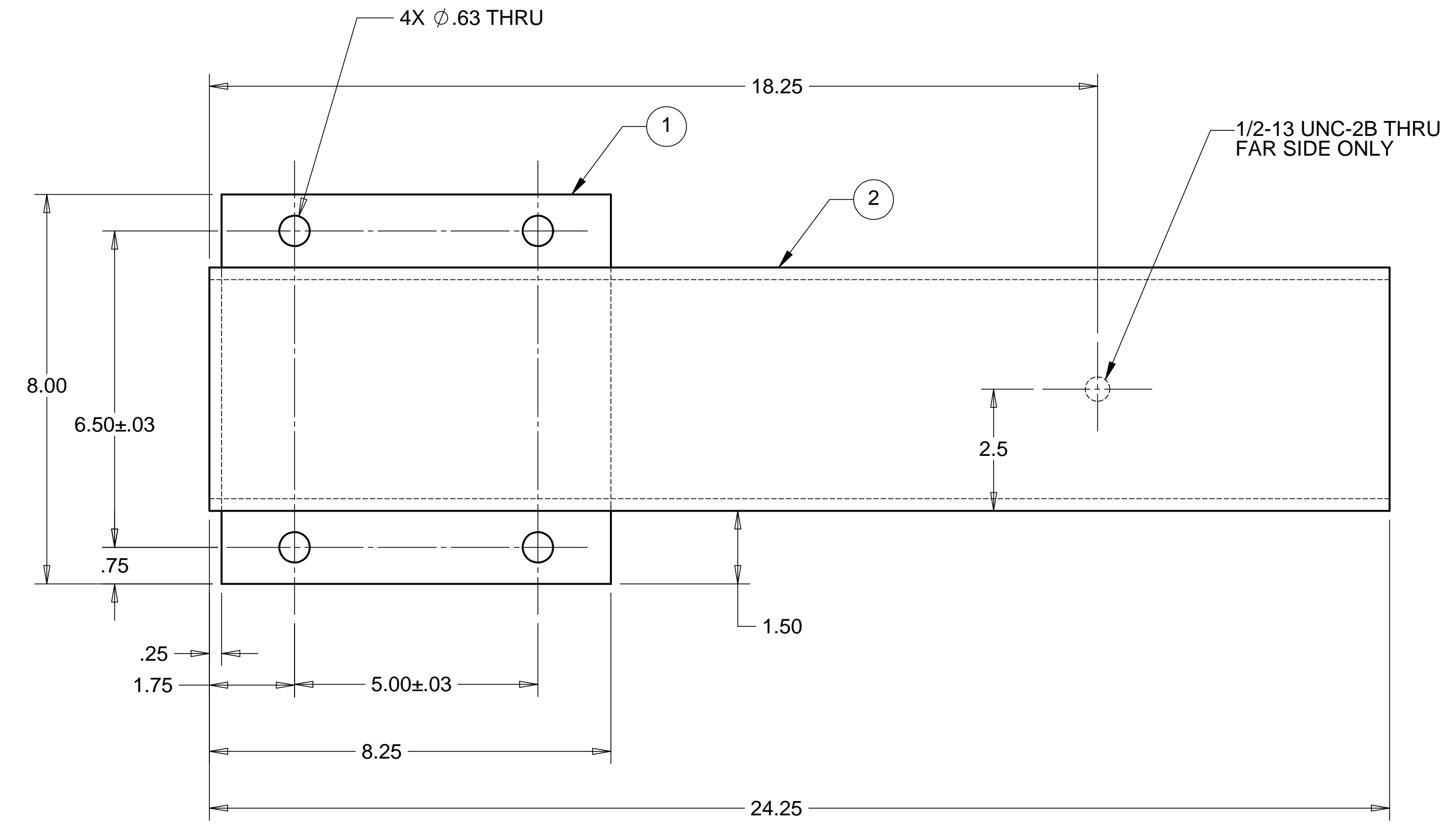

NOTES: UNLESS OTHERWISE SPECIFIED

1. ALL DIMENSIONS IN INCHES
2. DIMENSIONS AND TOLERANCING PER ASME Y14.5M-1994
3. SURFACE TEXTURE PER ANSI/ASME B 46.1-1985
4. REMOVE ALL BURRS AND BREAK SHARP EDGES TO A MAXIMUM OF .015
5. ALL INSIDE CORNERS TO BE .015 RADIUS MAX
6. COUNTERSINK 82 DEGREES ALL TAPPED HOLES TO MAJOR DIAMETER
7. COUNTERSINK 82 DEGREES APPROXIMATELY .015 DEEP ALL DRILLED HOLES
8. PARTS TO BE THOROUGHLY CLEANED TO REMOVE ALL OIL, GREASE, DIRT AND CHIPS
9. PART NUMBER (DRAWING NO. PLUS DASH NO. PLUS SERIAL NO.) TO BE CLEARLY MARKED ON THE PART ITSELF.
10. PART WEIGHS 33.3 Lbs.
11. PRIMER (ALL VISIBLE SURFACES): SHERMAN WILLIAMS INDUSTRIAL WASH PRIMER PG062.
12. PAINT (ALL VISIBLE SURFACES): SHERMAN WILLIAMS POLANE T POLYURETHANE COLOR BASIN, COLOR #F63TXL-4054-4352 FLAT.

ITEM NO.	QTY.	DESCRIPTION	MATERIAL
1	1	1/2" THK PLATE	A36 STEEL
2	1	TUBING, 2.5" X 5.0 X .25 WALL	A36 STEEL

PARTS LIST				HYTEC, INC	
UNLESS OTHERWISE SPECIFIED: DIMENSIONS ARE IN INCHES -TOLERANCES-		CAD GENERATED DRAWING, DO NOT MANUALLY UPDATE DO NOT SCALE DRAWING		TITLE <b>HAM CROSSBEAM CLAMP FORKLIFT FORK SLEEVE</b>	
DECIMALS X = +/- .1 .XX = +/- .06	ANGULAR = +/- 30' SURFACE FINISH = 250	SIGNATURE	DATE	DWG. NO.	SIZE SHEET NO.
FINISH		DESIGNED W. K. MILLER	12/12/97	D972919	D 1 of 1
		DRAWN W. K. MILLER	12/12/97		
PART NO. D972919-1		CHECKED HARRY SALAZAR	2/2/98		
		ENGR. T. THOMPSON	2/2/98		
		APPROVED T. THOMPSON	2/2/98	SCALE 1/2	REVISION A

8 7 6 5 4 3 2 1