

REVISIONS			
REV.	DESCRIPTION	DATE	APPROVED

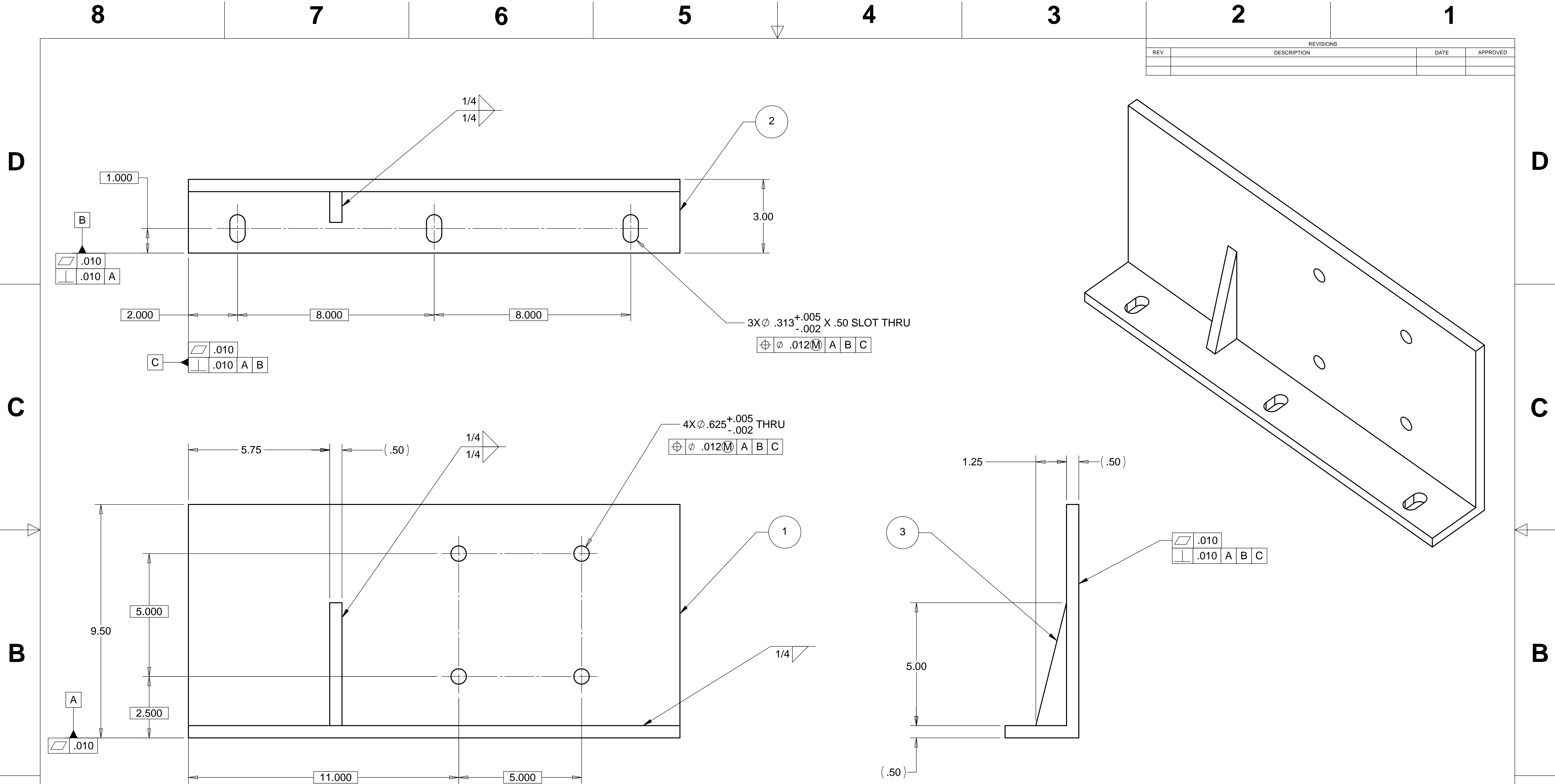

- A** NOTES: UNLESS OTHERWISE SPECIFIED
1. ALL DIMENSIONS IN INCHES
  2. DIMENSIONS AND TOLERANCING PER ANAS1 Y14.5M-1994
  3. SURFACE TEXTURE PER ANI/ASME B 46.1-1985
  4. REMOVE ALL BURRS AND BREAK SHARP EDGES TO A MAXIMUM OF .015
  5. ALL INSIDE CORNERS TO BE .015 RADIUS MAX
  6. COUNTERSINK 82 DEGREES ALL TAPPED HOLES TO MAJOR DIAMETER
  7. COUNTERSINK 82 DEGREES APPROXIMATELY .015 DEEP ALL DRILLED HOLES
  8. PARTS TO BE THOROUGHLY CLEANED TO REMOVE ALL OIL, GREASE, DIRT AND CHIPS
  9. PART NUMBER (DRAWING NO. PLUS DASH NO. PLUS SERIAL NO.) TO BE CLEARLY MARKED ON THE PART ITSELF.

**WEIGHT: 34.69 lbs**

ITEM NO.	QTY.	DESCRIPTION	MATERIAL
1	1	PLATE, .50 THK.	304 EZ CUT STAINLESS STEEL
2	1	PLATE, .50 THK.	304 EZ CUT STAINLESS STEEL
3	1	PLATE, .50 THK.	304 EZ CUT STAINLESS STEEL

PARTS LIST					
UNLESS OTHERWISE SPECIFIED: DIMENSIONS ARE IN INCHES -TOLERANCES-		CAD GENERATED DRAWING, DO NOT MANUALLY UPDATE DO NOT SCALE DRAWING			
DECIMALS	ANGULAR = +/- .30'	<p><b>HYTEC, INC</b></p> <p>TITLE: <b>BSC SUPPORT BRACKET LEFT SIDE WELDMENT</b></p>			
.X = +/- .1	SURFACE FINISH = 250				
.XX = +/- .03		DESIGNED	W. K. MILLER	DATE	2-1-98
.XXX = +/- .010		DRAWN	GERALD BUSTOS	DATE	2-1-98
FINISH		CHECKED	HARRY SALAZAR	DWG. NO.	
PART NO.		ENGR.	T. THOMPSON	D972434	
D972434-1		APPROVED	T. THOMPSON	SCALE	1/2
				SIZE	D
				SHEET NO.	1 of 1
				REVISION	