

8 7 6 5 4 3 2 1

REVISIONS			
REV.	DESCRIPTION	DATE	APPROVED

D

D

C

C

B

B

A

A

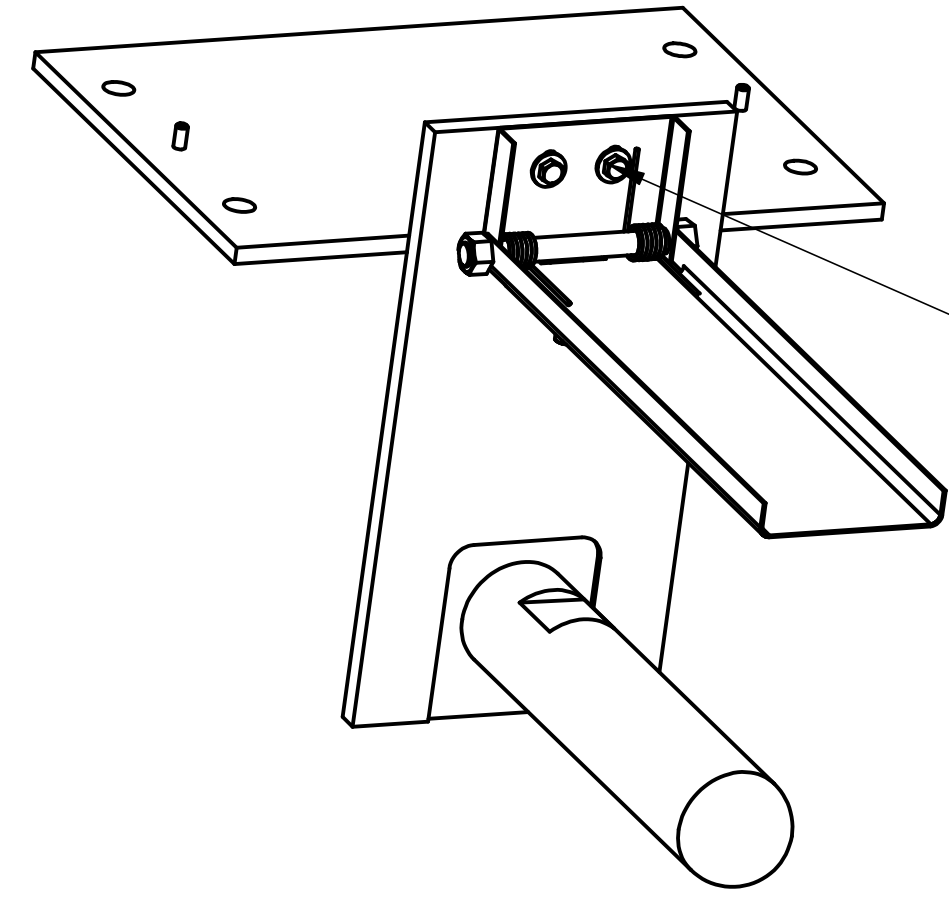

2X 2X
6 7

1

3

2

4 5

B REF.

A REF.

(11.00)

(8.75)

(.50)

∥ .03 A

(10.70)

(7.00)

WEIGHT: 48.2 lbs

ITEM NO.	QTY.	PART NO.	DESCRIPTION
1	1	D972422-1	BSC CENTERING JIG RIGHT SIDE
2	1	D972421-1	BSC CENTERING JIG POINT CONTACT
3	1	D972382-1	SUB-ASSEMBLY, Z-ELEVATION STAGE
4	1		BOLT, 1-8 UNC-2A X 1.25 LG., STAINLESS STEEL
5	1		WASHER, REGULAR 1.00 DIA., STAINLESS STEEL
6	2		SCREW, .250-20 UNC-2A X .50 LG., STAINLESS STEEL
7	2		WASHER, REGULAR .25 DIA., STAINLESS STEEL

PARTS LIST

UNLESS OTHERWISE SPECIFIED:
DIMENSIONS ARE IN INCHES
-TOLERANCES-

DECIMALS ANGULAR = +/- .30'
.X = +/- .1
.XX = +/- .03
.XXX = +/- .010 SURFACE FINISH = 250

CAD GENERATED DRAWING,
DO NOT MANUALLY UPDATE
DO NOT SCALE DRAWING

HYTEC, INC

TITLE
**BSC CENTERING JIG
LEFT SIDE
SUB-ASSEMBLY**

FINISH

PART NO.
D972381-1

SIGNATURE		DATE
DESIGNED	W. K. MILLER	1-14-98
DRAWN	GERALD BUSTOS	1-14-98
CHECKED	HARRY SALAZAR	----
ENGR.	T. THOMPSON	----
APPROVED	T. THOMPSON	----

DWG. NO.	SIZE	SHEET NO.
D972381	D	1 of 1

8 7 6 5 4 3 2 1