

8 7 6 5 4 3 2 1

REVISIONS		DATE	APPROVED
B	SEE ECN # D972202-B FOR CHANGE LIST	03/11/98	T. THOMPSON
C	SEE ECN # D972202-C FOR CHANGE LIST	03/20/98	T. THOMPSON
D	SEE ECN # D972202-D FOR CHANGE LIST	06/05/98	T. THOMPSON
E	SEE ECN # D972202-E FOR CHANGE LIST	09/03/98	T. THOMPSON

D

D

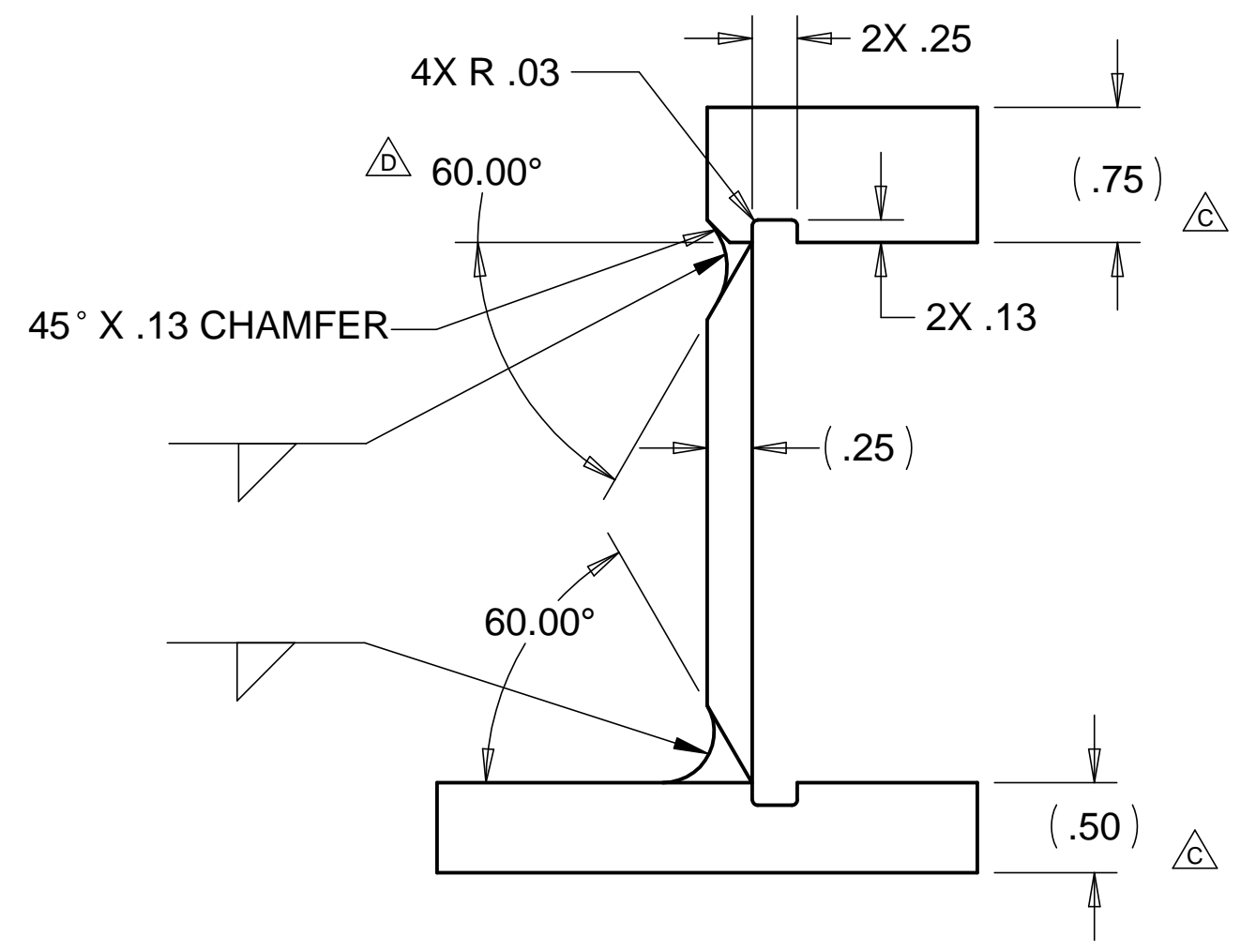

CONFIGURATION #1  
USED ON: D972711

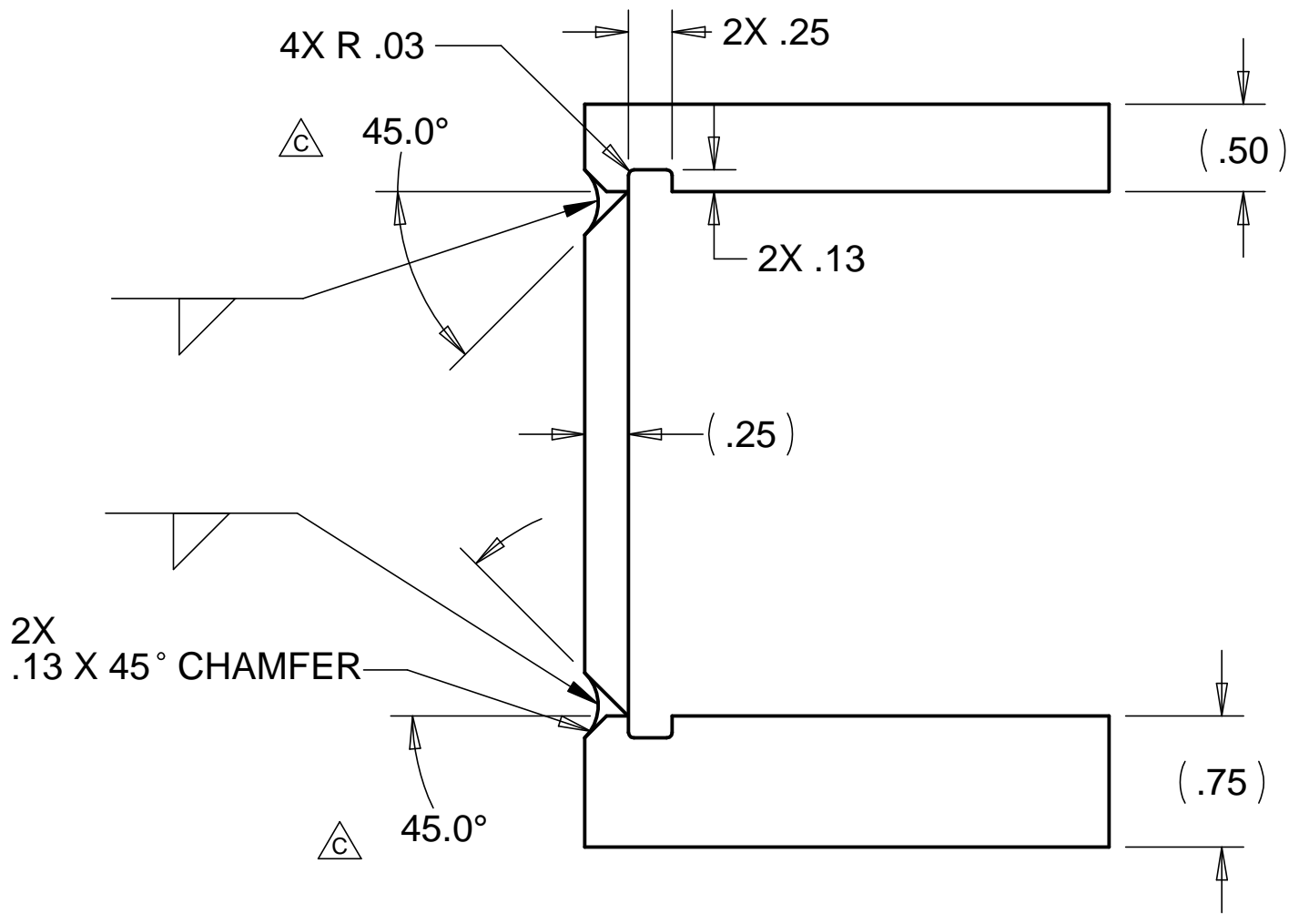

CONFIGURATION #2  
USED ON: D972211  
D972212  
D972710  
D972711

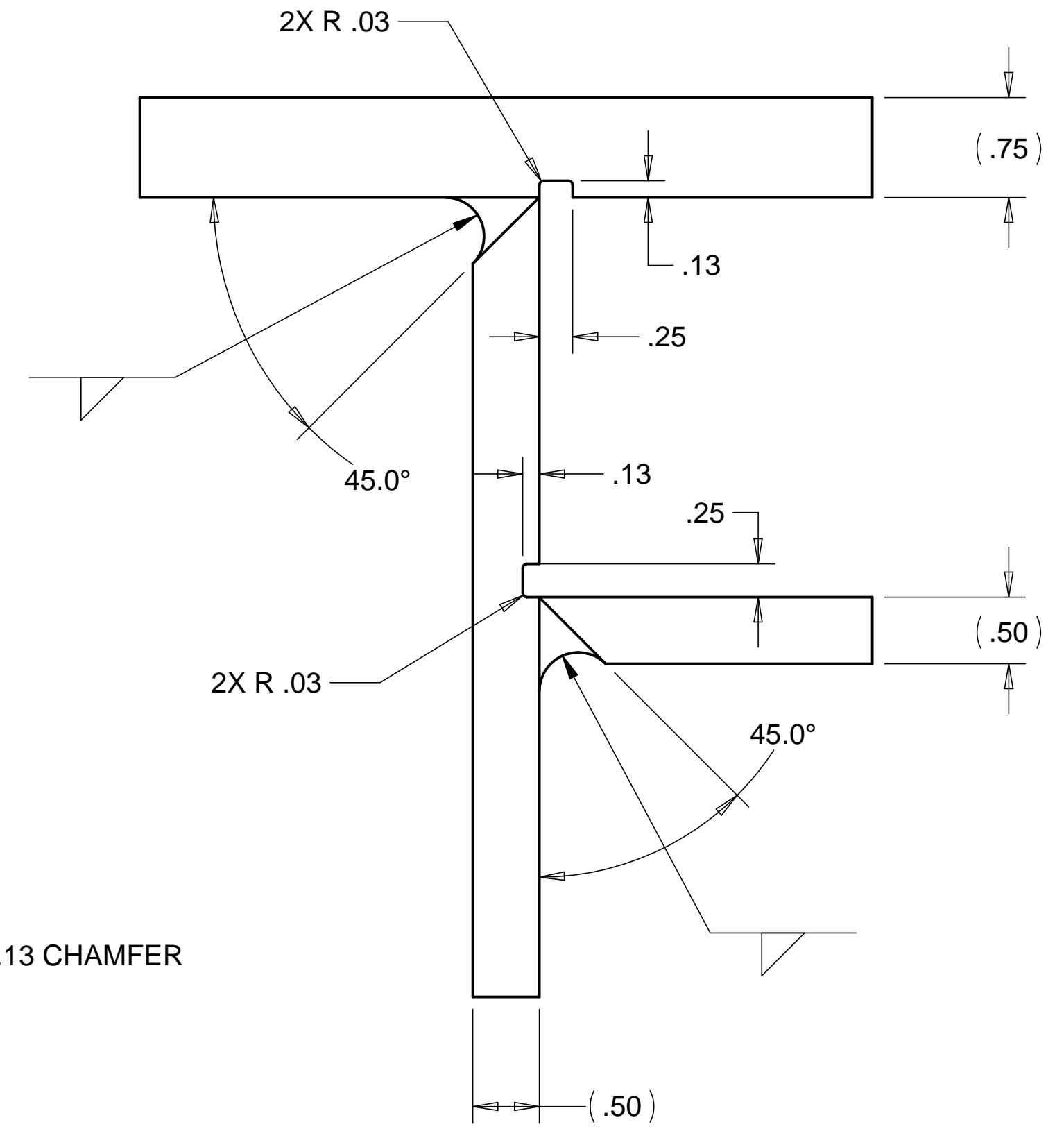

CONFIGURATION #3  
USED ON: D972212

C

C

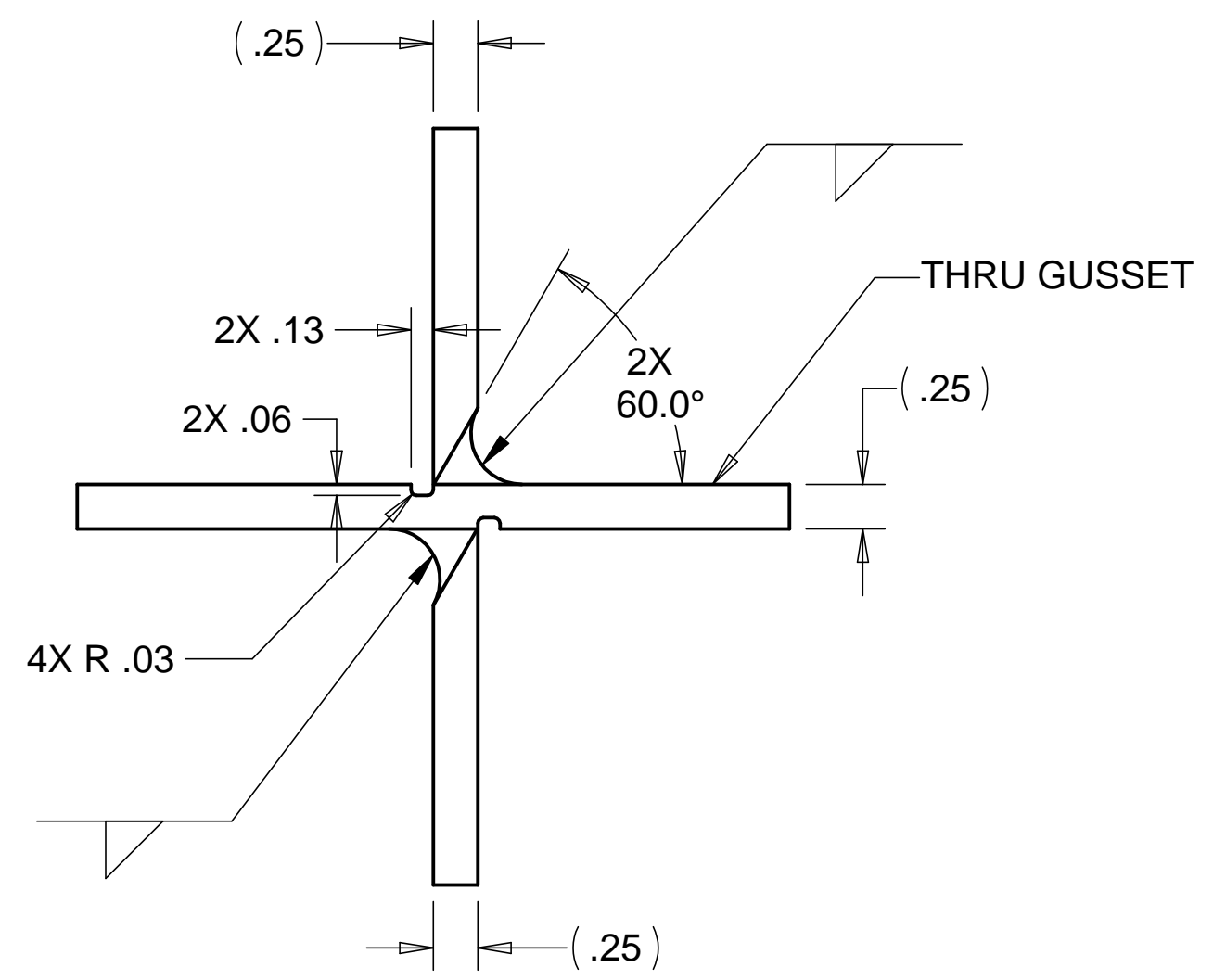

CONFIGURATION #4  
USED ON: D972211  
D972212  
D972710

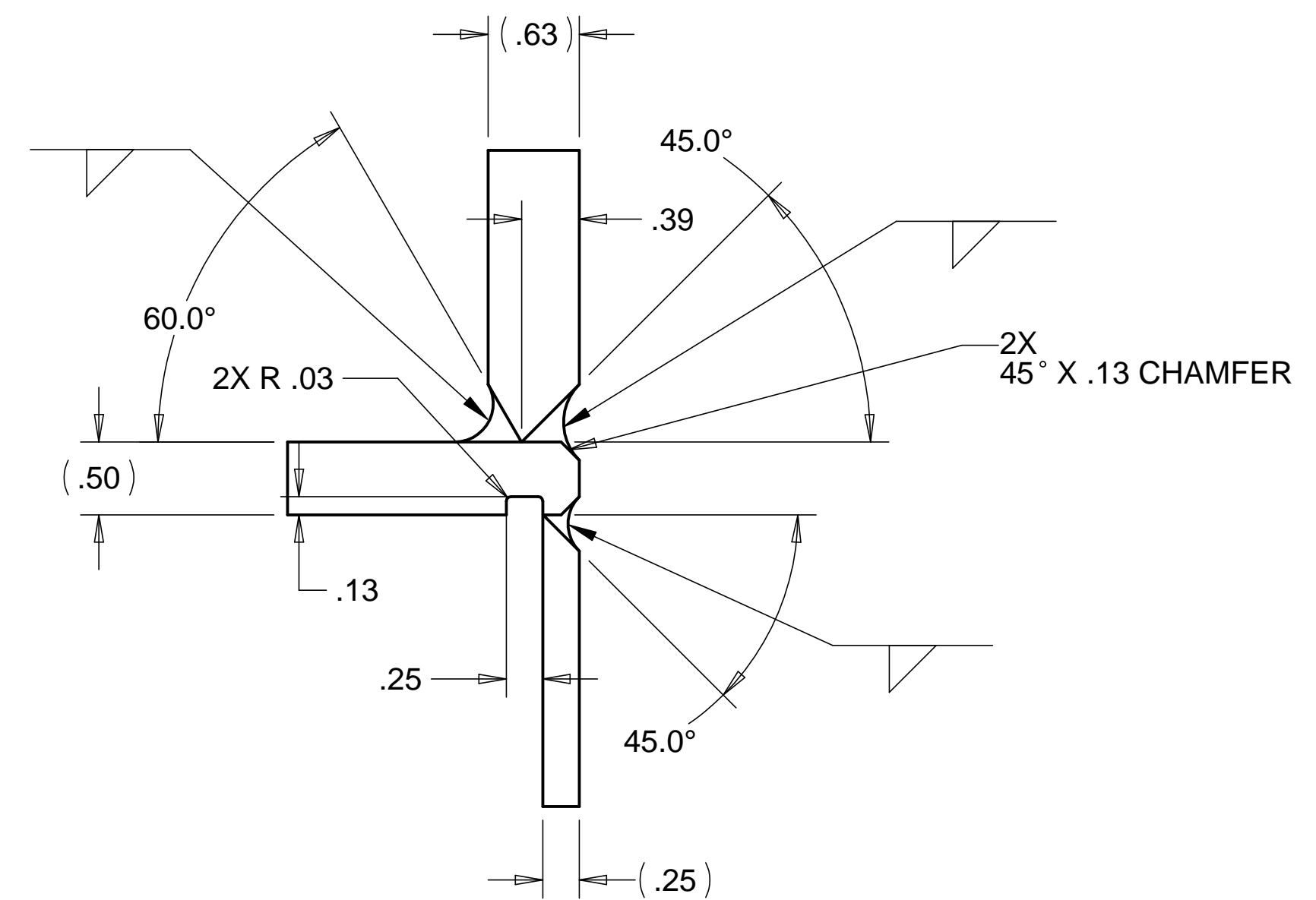

CONFIGURATION #5  
USED ON: D972211

B

B

A

A

NOTES:

1. WELD RELIEF GROOVES TO BE INTERMITANT, CENTERED ON WELD TABS. GROOVES TO BE 1/4" - 1/2" LONGER THAN LENGTH, EACH SIDE.
2. ALL ALUM. WELDING DONE BY A GTAW PROCESS USING 2% THORIATED TUNGSTEN WELDING ELECTRODES AND ER4043 WELDING ROD (SPEC. PER AWS A5.10-80).
3. NO SULFUR BASED CUTTING FLUIDS ALLOWED. APPROVED MACHINE LUBRICANT: HANSTERFER S-500CF.
4. WRAP WELD START/STOP CORNERS ON DOUBLE BEVEL WELDS (5,6,7,10,12,17) FOR VIRTUAL LEAK FREE WELD.
5. WELDS SHOULD BE CONTINUOUS OVER THE FULL LENGTH OF THE WELD PREPARATION.
6. WELDS SHOULD BE STRUCTURALLY SOUND. MULTIPLE PASSES MAY BE REQUIRED. OK TO NOT FILL COMPLETE.

PARTS LIST			
UNLESS OTHERWISE SPECIFIED: DIMENSIONS ARE IN INCHES -TOLERANCES-		CAD GENERATED DRAWING, DO NOT MANUALLY UPDATE DO NOT SCALE DRAWING	
DECIMALS .XX = +/- .03 .XXX = +/- .010	ANGULAR = +/- .30° SURFACE FINISH = 250	TITLE <b>HYTEC, INC</b> LIGO WELD CONFIGURATION & WELD PROCEDURE	
FINISH	SIGNATURE	DATE	DWG. NO.
	DESIGNED ROGER L. SMITH	5-28-97	SIZE
	DRAWN ROGER L. SMITH	5-28-97	SHEET NO.
	CHECKED HARRY SALAZAR	6-6-97	D972202
	ENGR. T. THOMPSON	7-10-97	D
	APPROVED T. THOMPSON	7-10-97	1 of 3
PART NO. D972202-1	SCALE 1/1	REVISION E	

8 7 6 5 4 3 2 1

8 7 6 5 4 3 2 1

REVISIONS		DATE	APPROVED
B	SEE ECN# D972202-B FOR CHANGE LIST	03/11/98	T. THOMPSON
C	SEE ECN# D972202-C FOR CHANGE LIST	03/20/98	T. THOMPSON
D	SEE ECN# D972202-D FOR CHANGE LIST	06/05/98	T. THOMPSON
E	SEE ECN# D972202-E FOR CHANGE LIST	09/03/98	T. THOMPSON

D

D

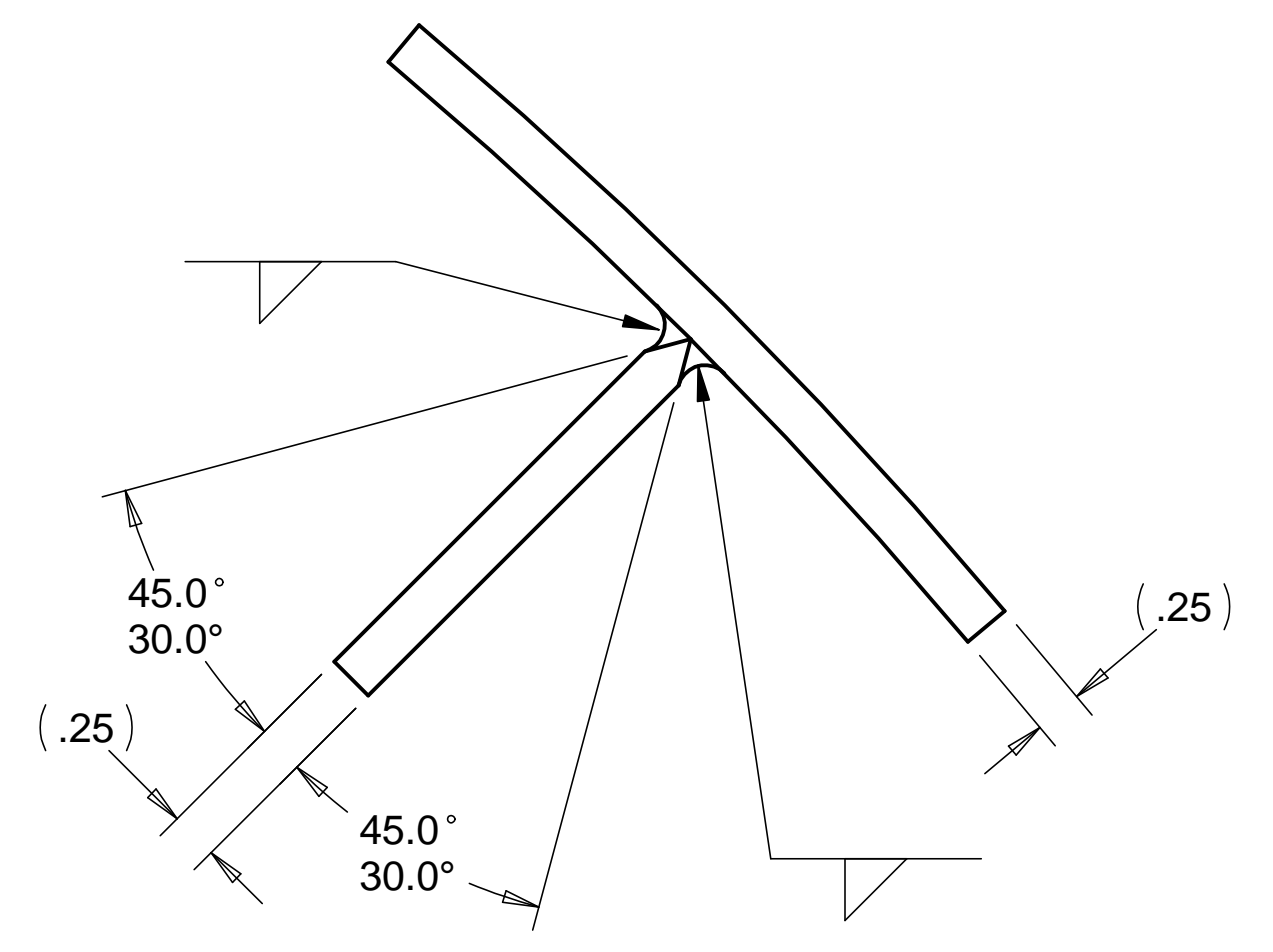

CONFIGURATION #7  
USED ON: D972211

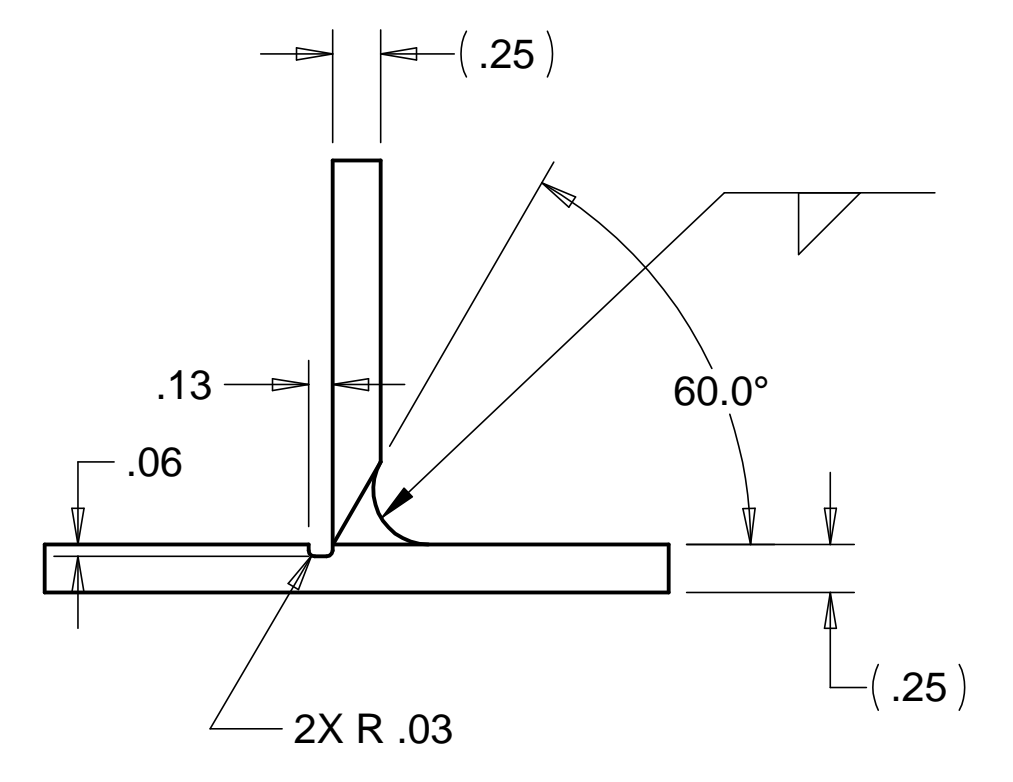

CONFIGURATION #8  
USED ON: D972710

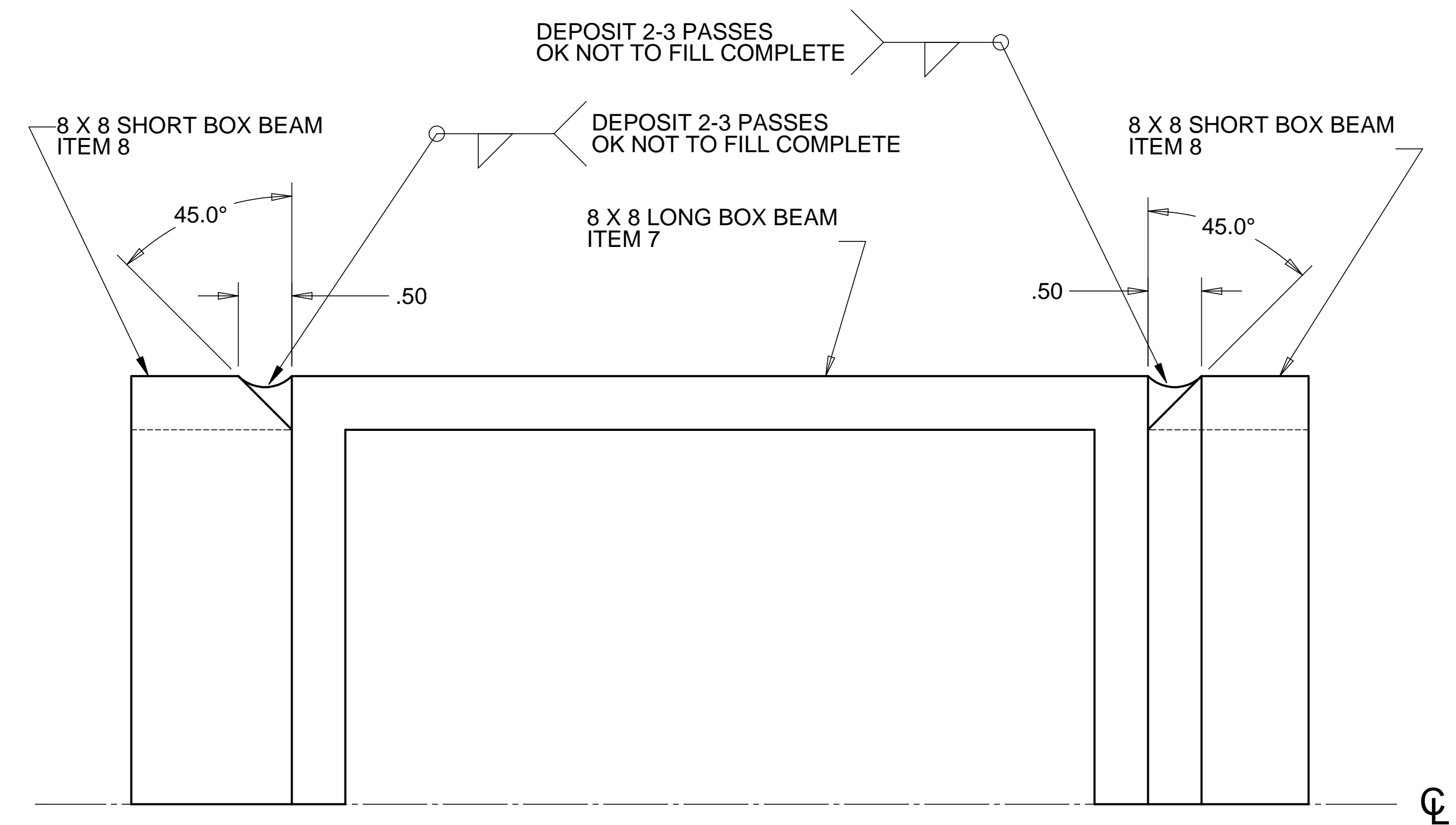

CONFIGURATION #9  
USED ON: D972211

C

C

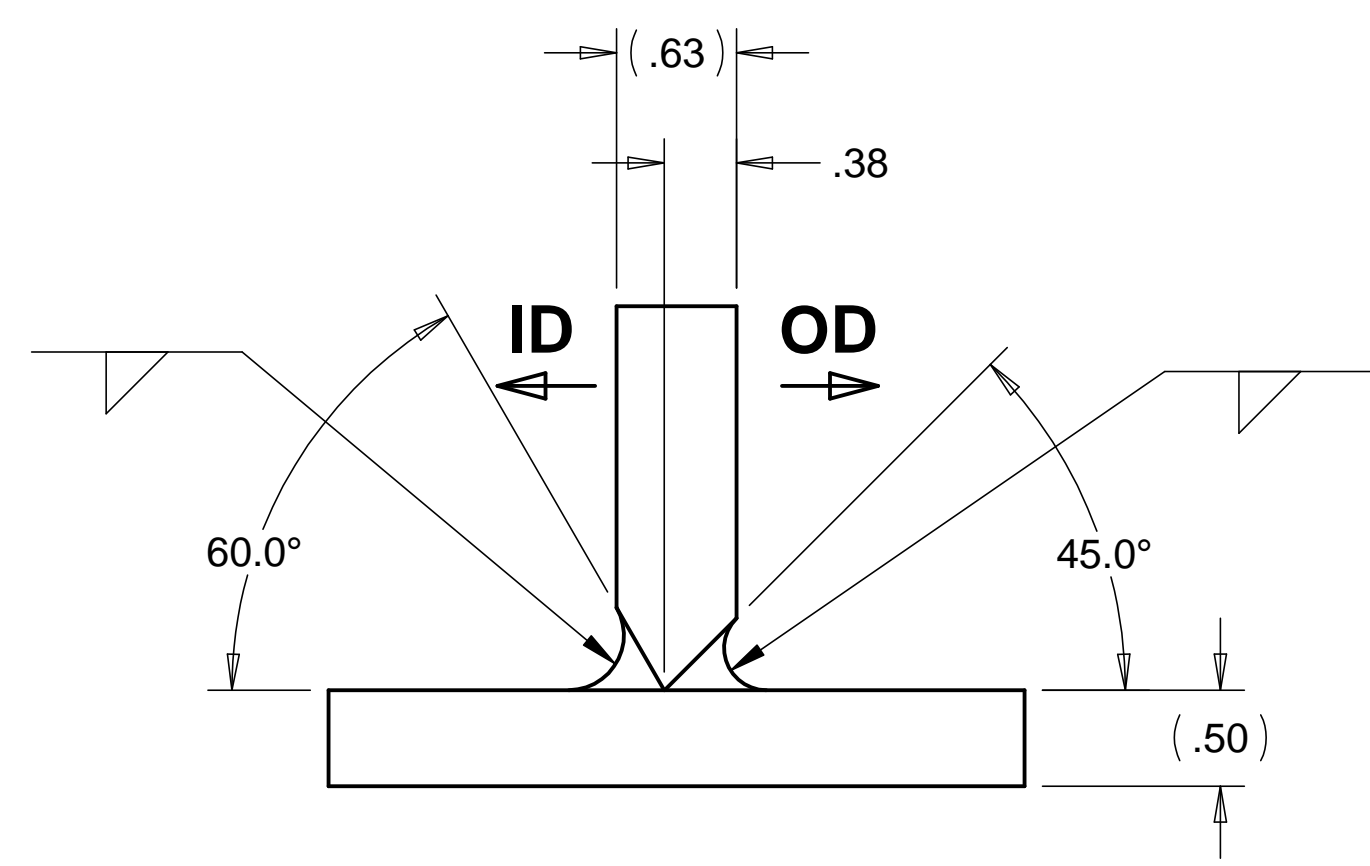

CONFIGURATION #10  
USED ON: D972211

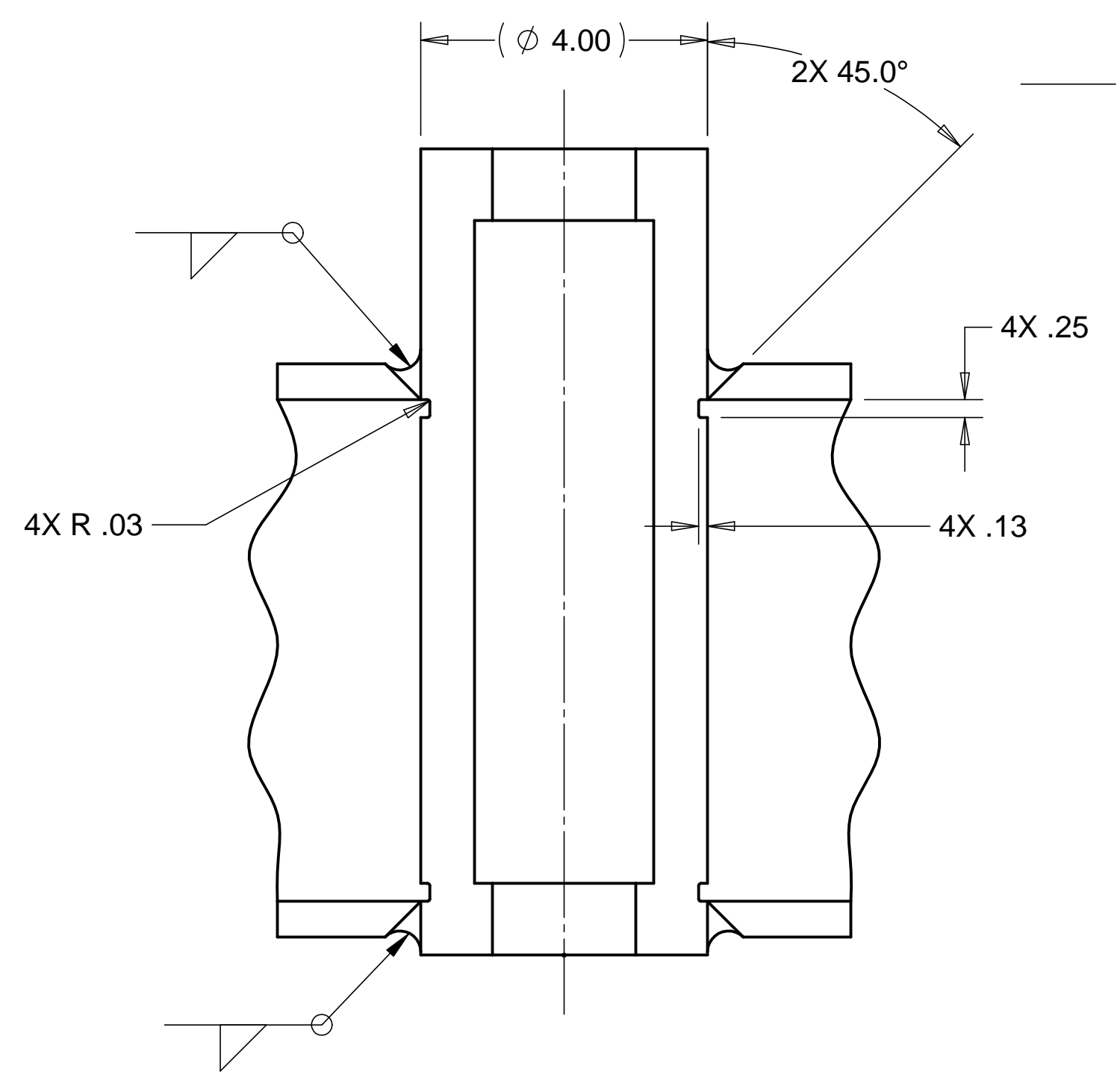

CONFIGURATION #11  
USED ON: D972211  
SCALE 1/2

B

B

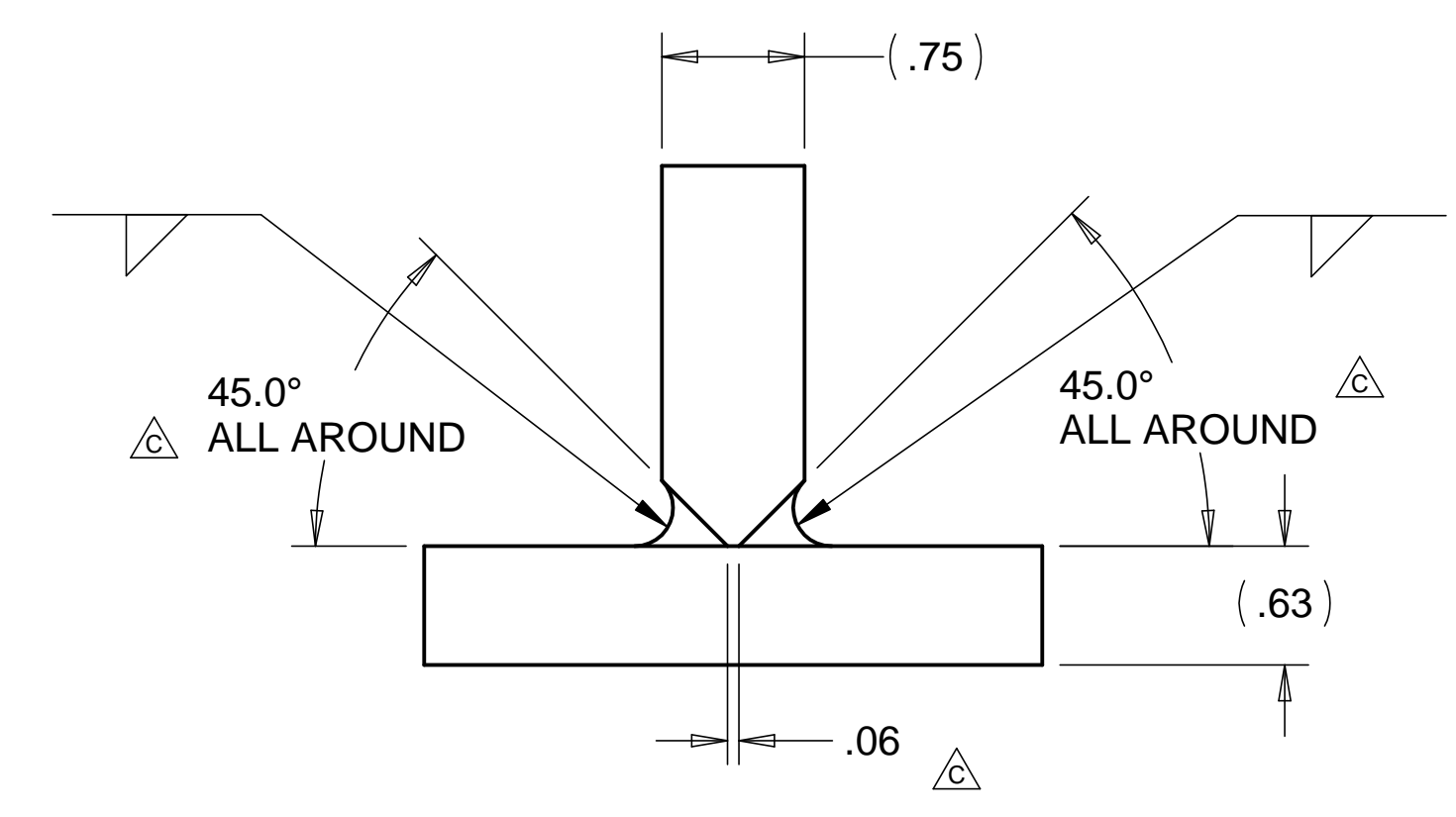

CONFIGURATION #12  
USED ON: D972211

A

A

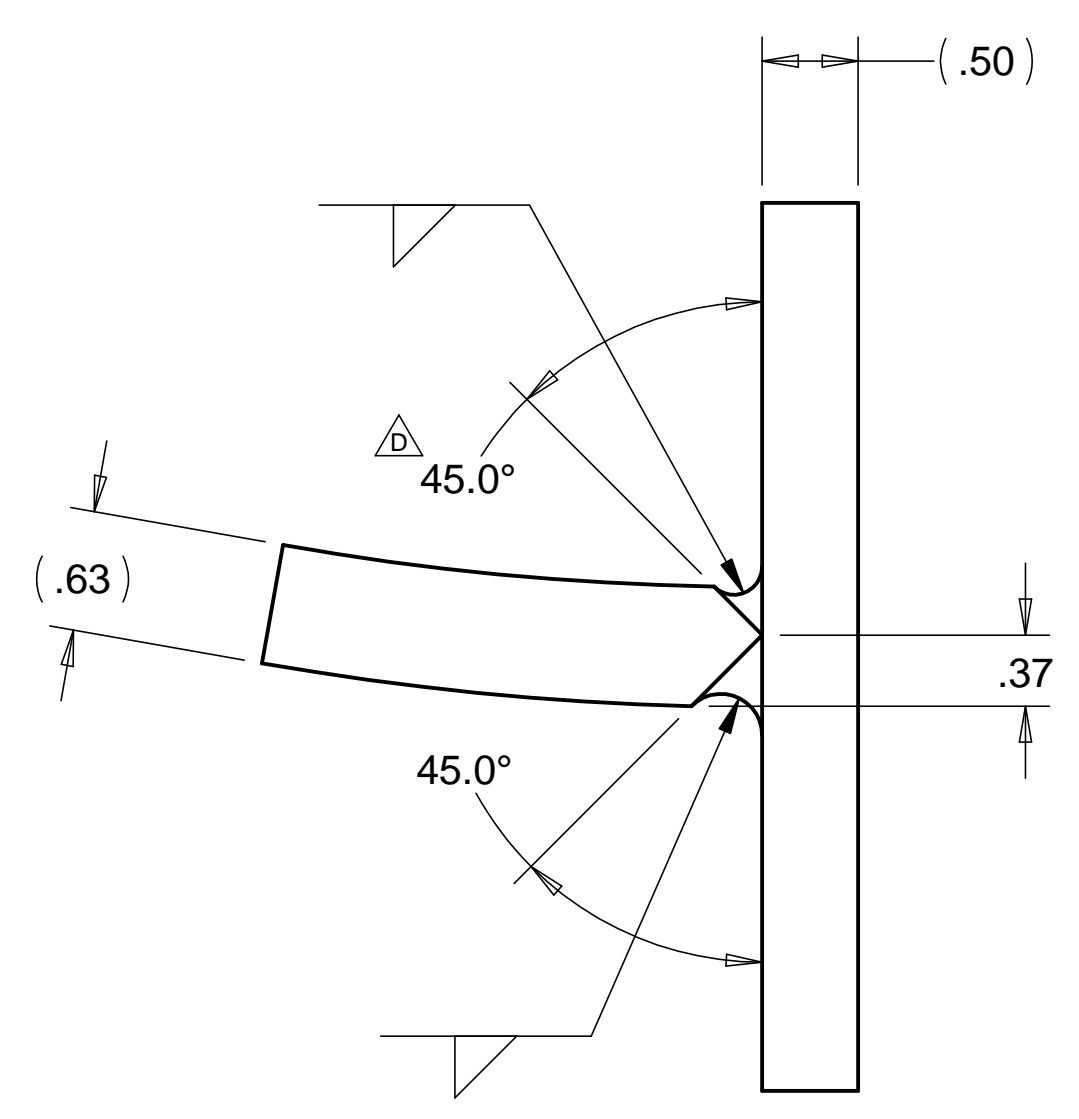

CONFIGURATION #6  
USED ON: D972211

PARTS LIST				HYTEC, INC	
UNLESS OTHERWISE SPECIFIED: DIMENSIONS ARE IN INCHES -TOLERANCES-		CAD GENERATED DRAWING, DO NOT MANUALLY UPDATE DO NOT SCALE DRAWING		TITLE <b>LIGO WELD CONFIGURATION &amp; WELD PROCEDURE</b>	
DECIMALS .X = +/- .1 .XX = +/- .03 .XXX = +/- .010	ANGULAR = +/- .30° SURFACE FINISH = 250	DESIGNED ROGER L. SMITH	DATE 03-09-98	DWG. NO. <b>D972202</b>	SIZE SHEET NO. <b>D 2 of 3</b>
FINISH		CHECKED T. THOMPSON	03-11-98	SCALE 1/1	REVISION E
PART NO. <b>D972202-1</b>		ENGR. T. THOMPSON	03-11-98		
		APPROVED T. THOMPSON	03-11-98		

8 7 6 5 4 3 2 1

8 7 6 5 4 3 2 1

REVISIONS		DATE	APPROVED
B	SEE ECN# D972202-B FOR CHANGE LIST	03/11/98	T. THOMPSON
C	SEE ECN# D972202-B FOR CHANGE LIST	03/20/98	T. THOMPSON
D	SEE ECN# D972202-B FOR CHANGE LIST	06/05/98	T. THOMPSON
E	SEE ECN# D972202-B FOR CHANGE LIST	09/03/98	T. THOMPSON

D

D

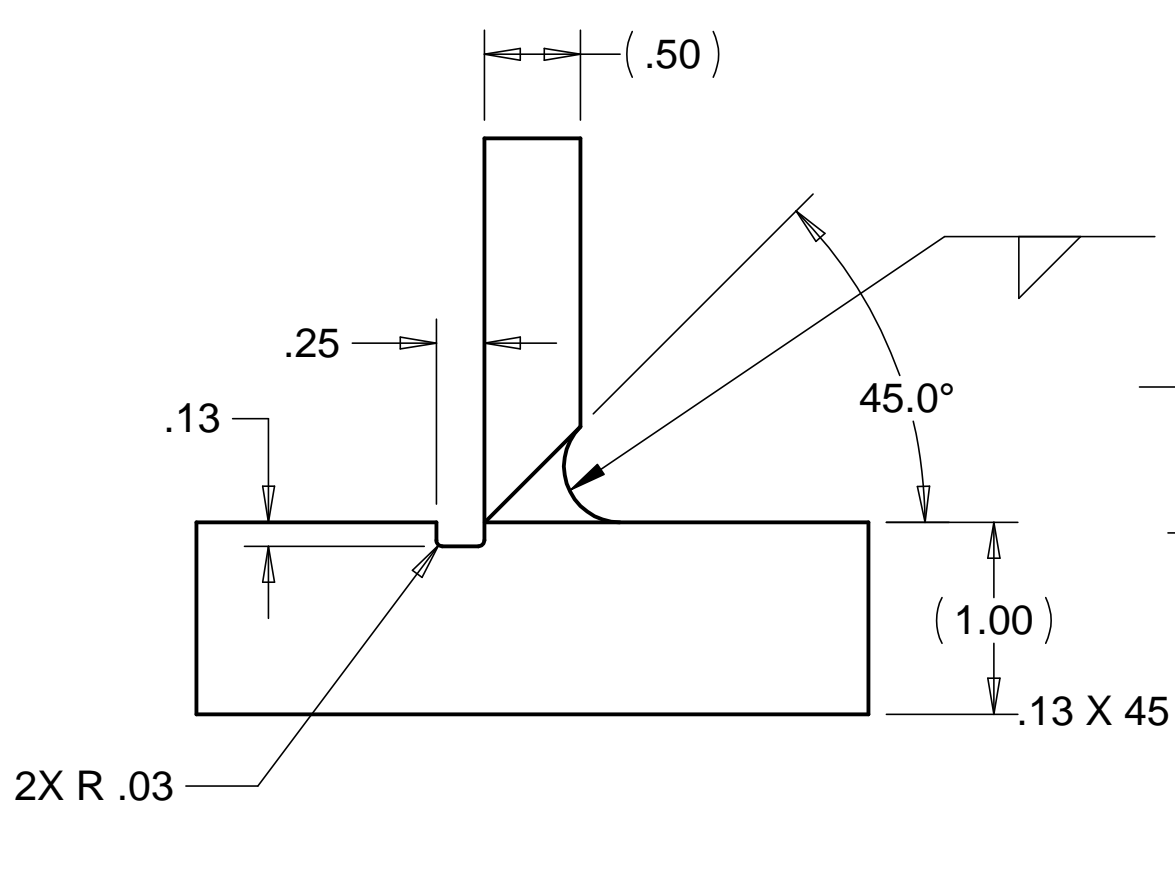

△ CONFIGURATION #13  
USED ON: D972211

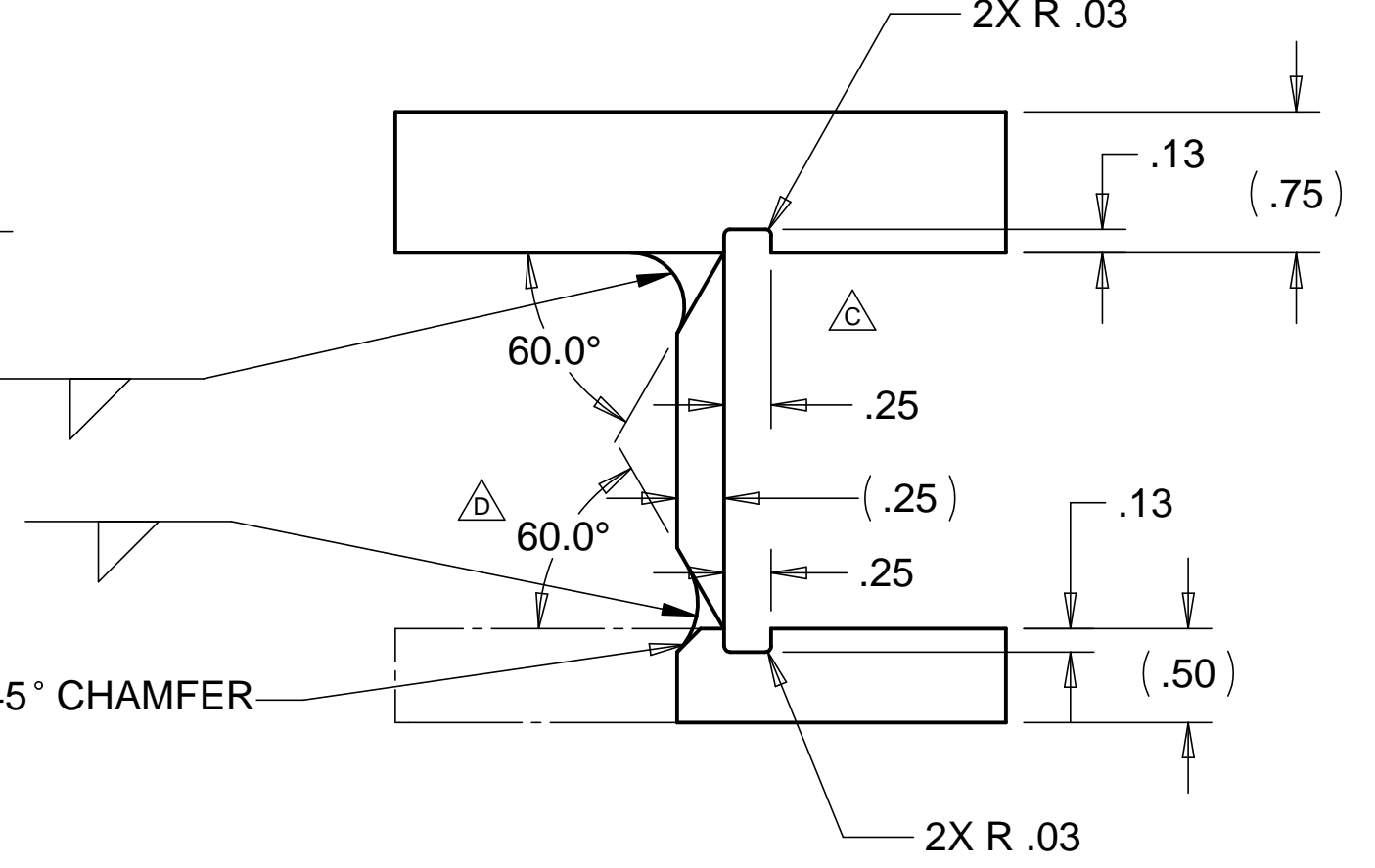

△ CONFIGURATION #14  
USED ON: D972211  
D972212  
D972710  
D972711

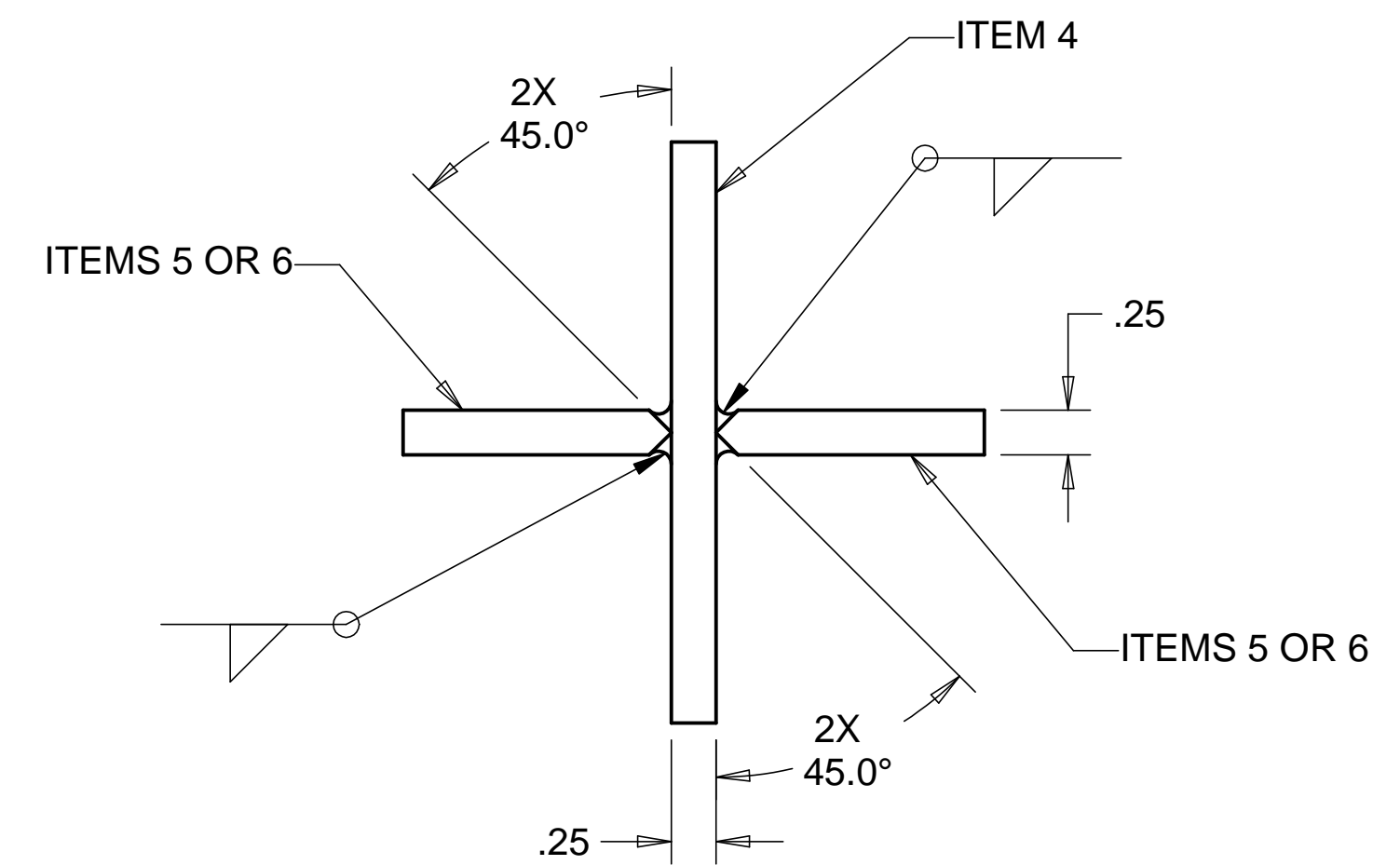

△ CONFIGURATION #19  
USED ON: D972711

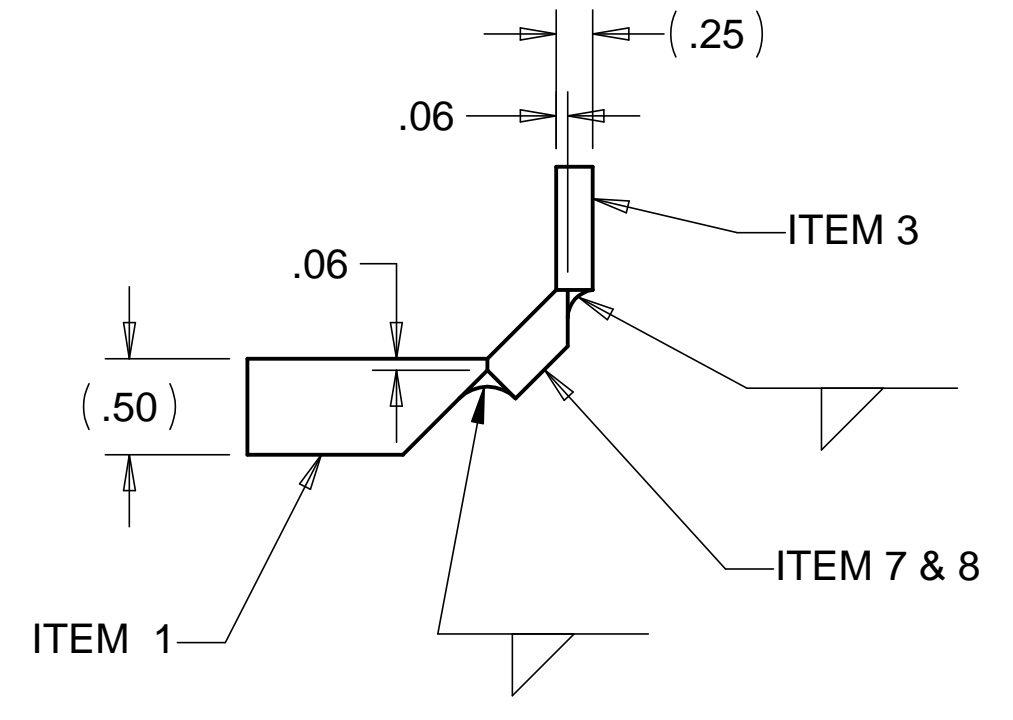

△ CONFIGURATION #22  
USED ON: D972711

C

C

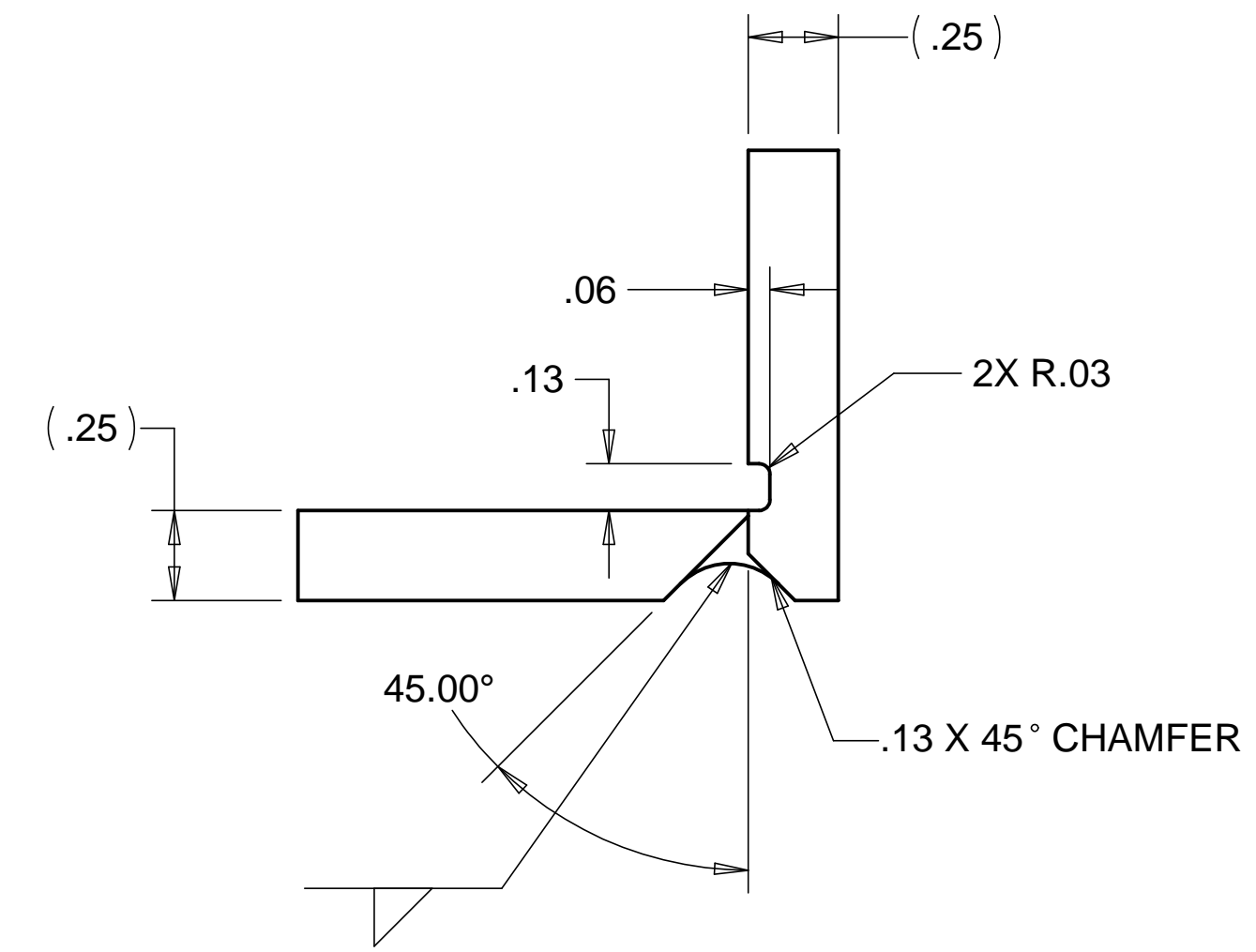

△ CONFIGURATION #15  
USED ON: D972710

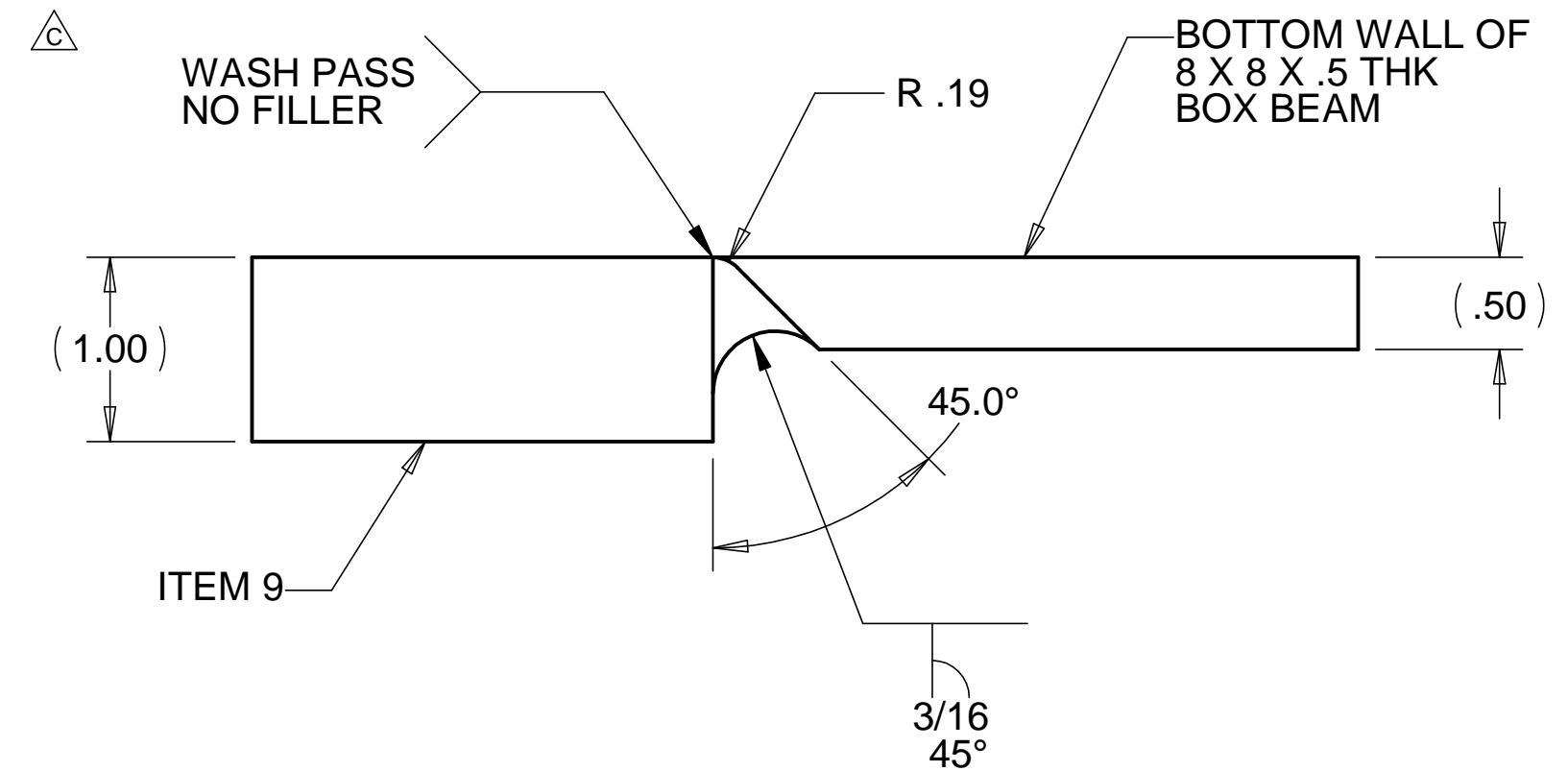

△ CONFIGURATION #16  
USED ON: D972211

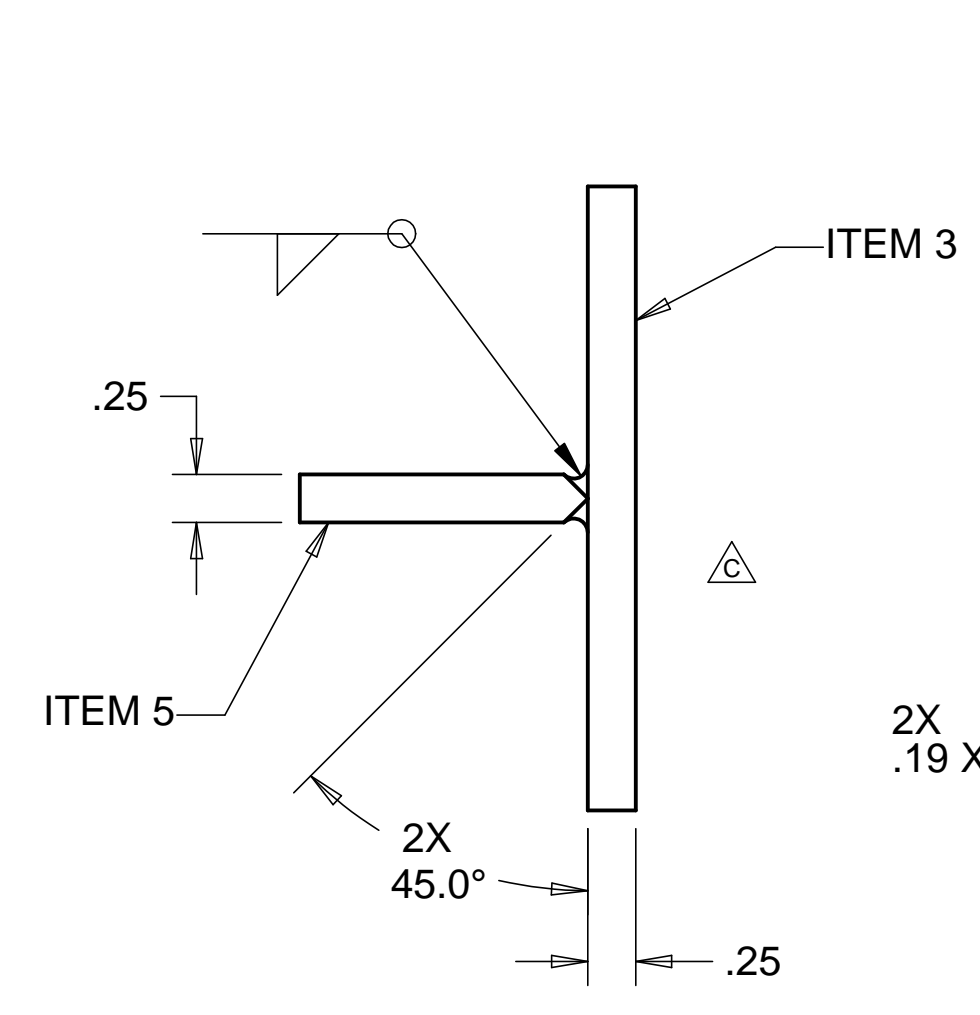

△ CONFIGURATION #20  
USED ON: D972711

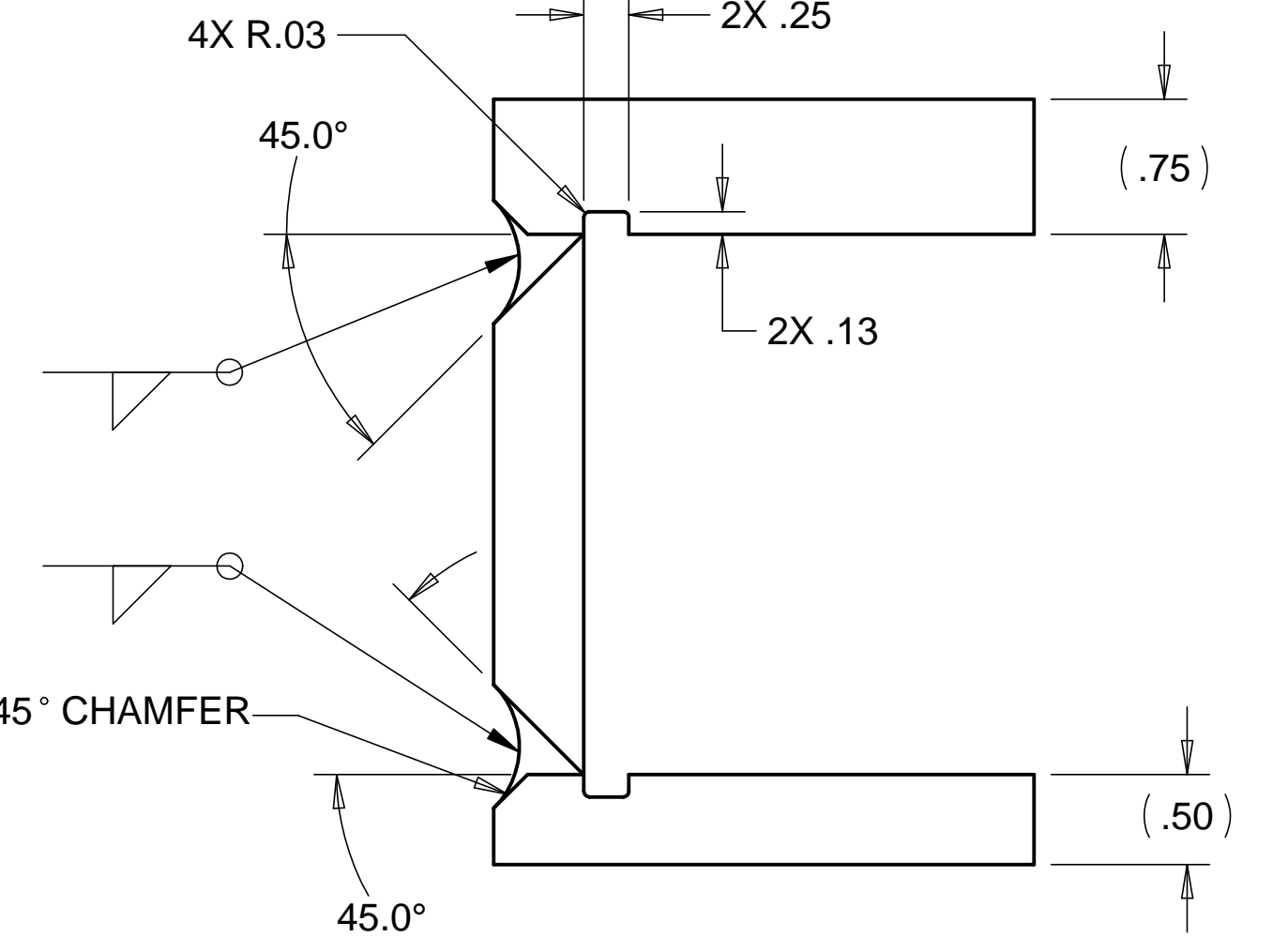

△ CONFIGURATION #21  
USED ON: D972212

B

B

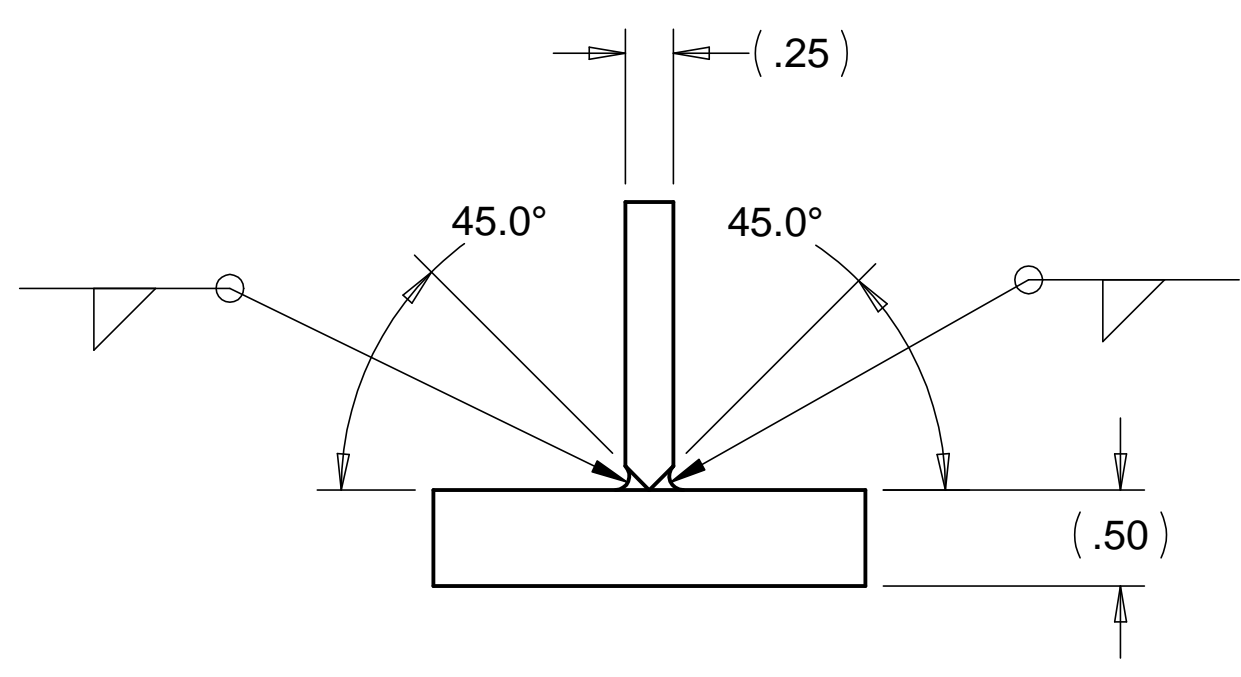

△ CONFIGURATION #17  
USED ON: D972211

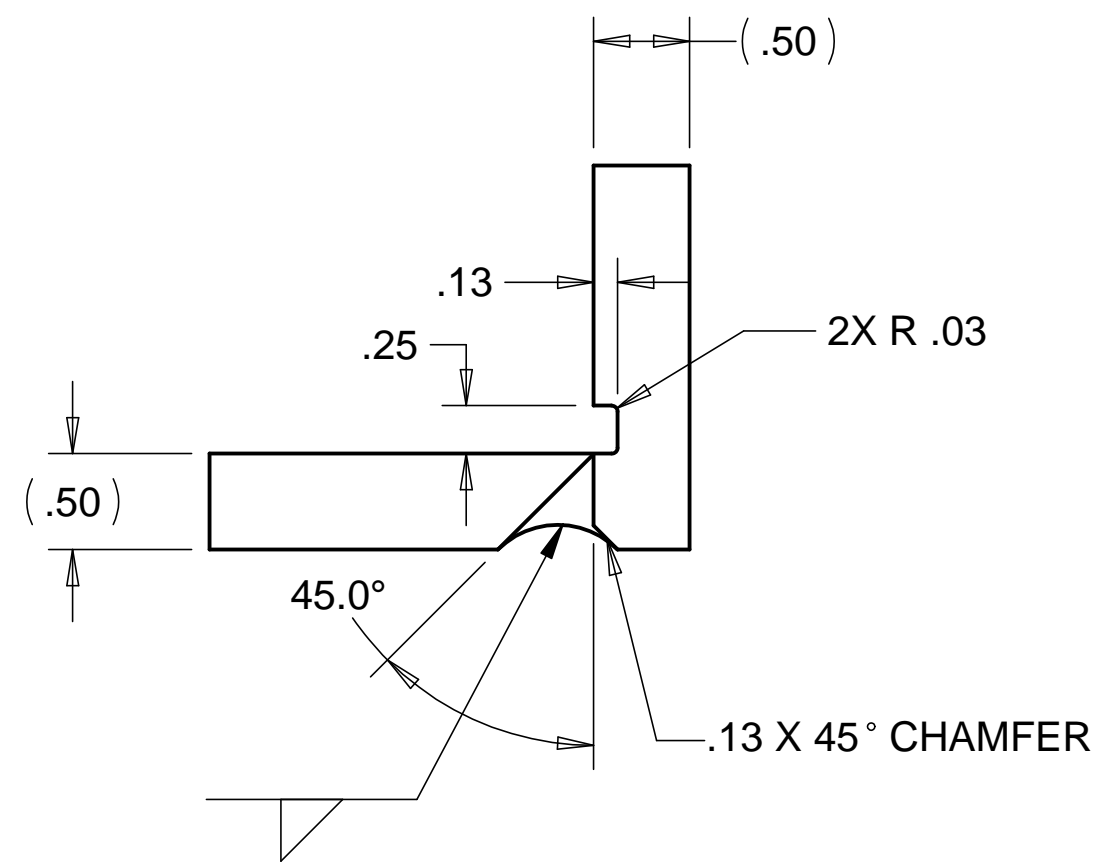

△ CONFIGURATION #18  
USED ON: D972212

A

A

PARTS LIST			
UNLESS OTHERWISE SPECIFIED: DIMENSIONS ARE IN INCHES -TOLERANCES-		CAD GENERATED DRAWING, DO NOT MANUALLY UPDATE DO NOT SCALE DRAWING	
DECIMALS X = +/- .1 .XX = +/- .03 .XXX = +/- .010	ANGULAR = +/- 30' SURFACE FINISH = 250	TITLE <b>HYTEC, INC</b> LIGO WELD CONFIGURATION & WELD PROCEDURE	
FINISH	SIGNATURE	DATE	DWG. NO.
	ROGER L. SMITH	03-09-98	D972202
DRAWN	ROGER L. SMITH	03-09-98	SIZE
CHECKED	T. THOMPSON	03-11-98	D 3 of 3
ENGR.	T. THOMPSON	03-11-98	REVISION
APPROVED	T. THOMPSON	03-11-98	E
PART NO. <b>D972202-1</b>		SCALE 1/1	

8 7 6 5 4 3 2 1