

**PACKAGING/LIFTING/SHIPPING INSTALLATION**

1. REFERENCE DOCUMENTS  
COMPONENT PACKAGING, HANDLING, SHIPPING  
PROCEDURE - V049-2-123  
CONTAMINATION CONTROL PLAN - V049-2-119
2. PROTECT BELLOWS BY WRAPPING WITH HEAVY PLASTIC STRIPS  
PRIOR TO BAGGING.
3. ENTIRE VESSEL TO BE SHRINK WRAPPED WITH 2 LAYERS  
OF 6 MIL POLYETHYLENE.
4. VESSEL TO BE MOUNTED ON TRAILER IN  
ORIENTATION SHOWN.
5. TIGHTEN BELLOWS TIE RODS TO LOCK IN  
NEUTRAL LENGTH POSITION.
6. REMOVE FROM TRAILER AT SITE BY LIFTING  
WITH STRAPS AT LOCATIONS SHOWN.
7. SECURELY ATTACH THESE LIFTING INSTRUCTIONS  
TO VESSEL IN A WATER PROOF  
POLYETHYLENE BAG.
8. VESSEL TO BE SHIPPED STRAPPED TO TRUCK AT  
CRADLE LOCATIONS SHOWN.
9. COVER WITH CLEAN TIGHT TARPS DURING SHIPPING.
10. VESSEL TO BE SHIPPED VIA AIR RIDE  
TRAILOR ONLY.

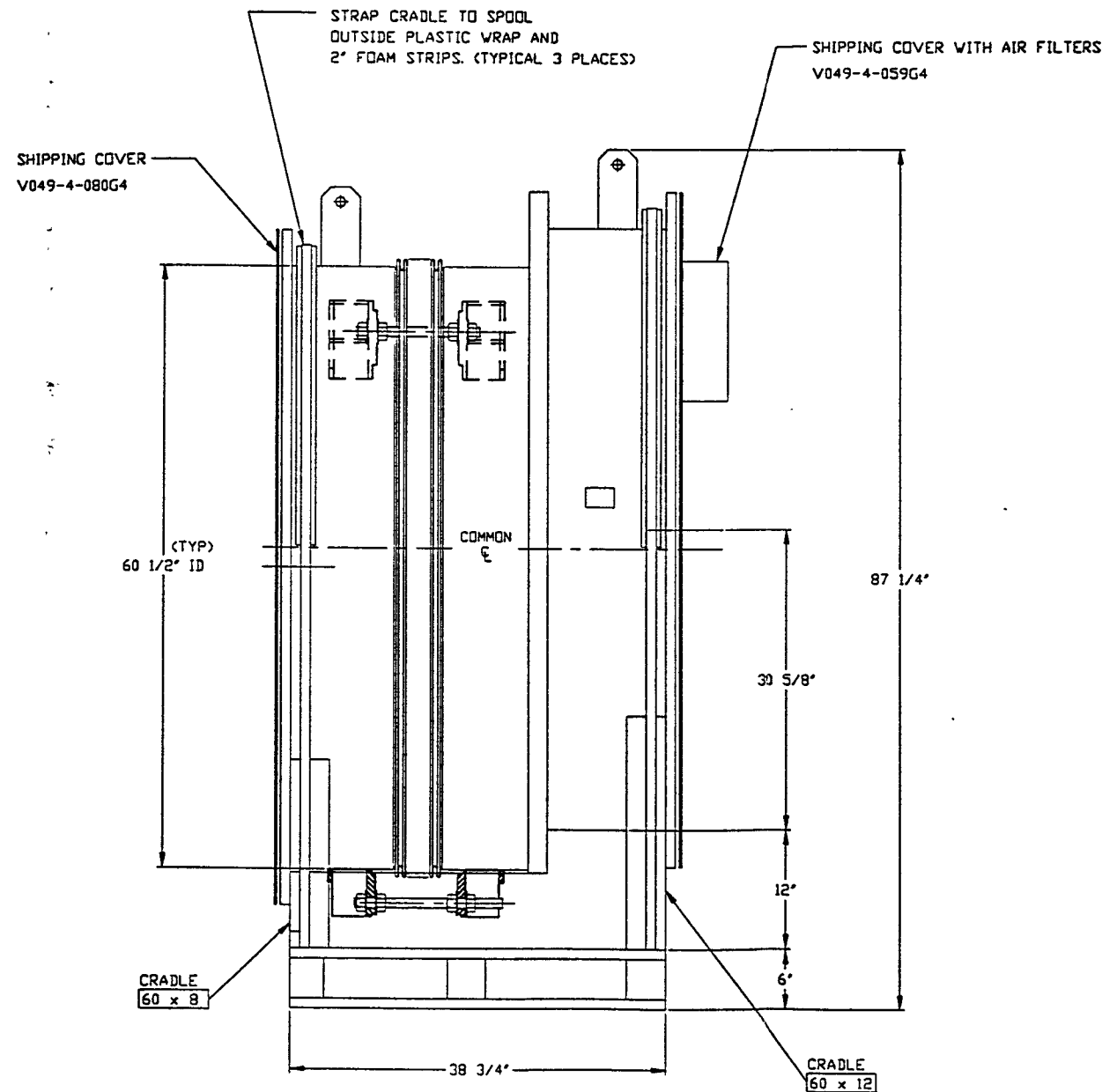

NOTE! THE TRUCK DRIVER IS TO ADD  
PROPER BRACING TO PREVENT  
FORWARD OR AFT MOVEMENT  
OF THE LOAD DURING SHIPMENT.

SHT 13 OF 14 APPROX. WEIGHT: 2275#

|  |  |                                  |  |                         |  |                        |  |   |  |
|--|--|----------------------------------|--|-------------------------|--|------------------------|--|---|--|
| <p>UNLESS OTHERWISE SPECIFIED<br/>DIMENSIONS ARE IN INCHES<br/>TOLERANCES:<br/>FRACTIONAL ± 1/16"<br/>ANGULAR APPROX ± 30° MIN 12°<br/>TWO PLACE DECIMAL ± .03<br/>THREE PLACE DECIMAL ± .015<br/>FINISHED SURFACE ONLY<br/>BREAK CORNERS (R) (D)<br/>REMOVE ALL BURRS</p> |  | <p>DO NOT SCALE THIS DRAWING</p> |  | <p>0 ISSUED FOR FDR</p> |  | <p>DA 6/30/97 0495</p> |  | <p>PROCESS SYSTEMS INTERNATIONAL, INC.<br/>20 WALRUP DR. WESTBOROUGH, MASSACHUSETTS 01581 USA</p> |  |
| <p>DESCRIPTION</p>   |  | <p>DESCRIPTION</p>               |  | <p>CHKD</p>             |  | <p>DATE</p>            |  | <p>SCALE</p>  |  |
| <p>REFERENCE DRAWINGS</p>  |  | <p>ISSUE DESCRIPTION</p>         |  | <p>REV</p>              |  | <p>DATE</p>            |  | <p>SCALE</p>  |  |
| <p>DWG. NO.</p>  |  | <p>DESCRIPTION</p>               |  | <p>CHKD</p>             |  | <p>DATE</p>            |  | <p>SCALE</p>  |  |
| <p>DWG. NO.</p>  |  | <p>DESCRIPTION</p>               |  | <p>CHKD</p>             |  | <p>DATE</p>            |  | <p>SCALE</p>  |  |