

**250 mm Valve and Type "H" Pump Port Hardware
Field Assembly Instructions**

- Remove temporary cover from the pump port. **CAUTION THE FLANGE IS A "CONFLAT" TYPE FLANGE WITH A KNIFE EDGE WHICH SEALS TO A COPPER GASKET. EVEN VERY SLIGHT DAMAGE TO THE KNIFE EDGE WILL RESULT IN UNACCEPTABLE FLANGE LEAKAGE AND WILL REQUIRE REPLACEMENT OF THE DAMAGED FLANGE. ALL FLANGES WITHIN THE PUMP PORTS AND PUMP PORT HARDWARE ARE CONFLAT FLANGES AND SHALL BE TREATED DELICATELY AND COVERED WHENEVER POSSIBLE TO PREVENT DAMAGE TO THE KNIFE EDGE. DO NOT EXPOSE FLANGES OR SEALS IN A WINDY OR DUSTY ENVIRONMENT. TAKE CARE TO NOT DROP PARTICLES INTO VALVES OR ONTO FLANGES. DO NOT REST FLANGES ON THEIR FACE UNLESS ON A CLEAN, SOFT SURFACE.**
- Clean the port vacuum surfaces with a clean lint free cloth and Isopropyl Alcohol. Cleanroom gloves shall be used during cleaning and installation of the valve and PPH (pump port hardware).
- Remove the nozzle cover from the "gate" side of the 250 mm (10" diameter) valve and inspect for cleanliness. Clean if necessary with a clean lint free cloth and Isopropyl Alcohol. The "gate" side is the side of the valve with the gate o-ring.
- Install the gate side of the valve to the pump port flange using a new Conflat type copper gasket. Installation of the valve is accomplished by first ensuring that the gasket is within the groove all around the flange such that the gasket is exactly centered and will not be trapped and pinched by the flat faced surfaces of the flange. The bolts are then finger tightened while ensuring that the gasket does not move out of the gasket groove. The bolts are tightened in a rotary sequence (not across the flange sequence like tire lug nuts). The bolts are tightened approximately 1/4 turn each time around the flange until the bolts remain tight at a torque of 345 in lb. The flanges should be metal to metal, which means that the gasket has been compressed enough that the flange faces are touching. If the flanges are not metal to metal, check for misalignment of the gasket, if not misaligned, continue to tighten bolts until the flange is metal to metal. **GASKETS CANNOT BE REUSED.** Replace the gasket each time the flange is installed. If the gasket is damaged in any way, replace with a new gasket.
- Remove the cover from the other end of the 250 mm valve. Inspect and clean if necessary with a lint free cloth and isopropyl alcohol.
- Remove the cover or packaging from a type "H" hardware blind flange. Clean with a lint free cloth and isopropyl alcohol. Install the type "H" hardware on the 250 mm valve. Follow the same flange assembly instructions as in step 4 above.

**Changing Type "B" to Type "H" Pump Port Hardware
Field Assembly Instructions**

- Close the 250 mm pump port isolation valve.
- Vent the type "B" hardware using on of the 40 mm valves.
- Remove any pumps or the calibration module from the type "B" hardware and replace blind flange where the system is removed.
- Move a pallet mover into position under the type "B" hardware and raise until it is taking most of the hardware module's weight.
- Remove the bolts between the 250 mm valve and the "B" hardware.
- Raise the hardware legs and move the type "B" hardware away from the pump port using the pallet mover.
- Cover the open flange of the type "B" hardware.
- Remove the temporary cover from the type "H" hardware.
- Inspect and clean the type "H" hardware and the flange of the 250 mm valve. **CAUTION, DO NOT OPEN THE 250 MM VALVE BECAUSE THE BEAM TUBE IS UNDER VACUUM. OPENING OF THE 10" VALVE UNDER VACUUM CAN RESULT IN PERSONNEL INJURY OR DEATH IF THE PERSON IS DRAWN INTO THE PARTIALLY OPEN VALVE. IT WILL ALSO DAMAGE THE VALVE AND CAN RESULT IN A COSTLY CONTAMINATION OF THE BEAM TUBE. ALSO SEE CAUTION NOTES IN STEP 1 OF THE ABOVE SECTION.**
- Using a new gasket, bolt the type "H" hardware to the 250 mm valve.
- Leak test the connection of the "H" hardware to 250 mm pump port isolation valve in accordance with procedure HMST3N. If leak free, go to next step. If any leaks are found, repair and recheck for leaks.
- Following leak testing, attach an auxiliary pumping system to the 40mm valve and evacuate the "H" hardware to 1x10⁻⁵ torr.
- Close the 40 mm valve on the "H" hardware. Stop the pumping system as recommended in the operations manual and remove the pump skid from the "H" hardware.
- Reinstall the blank flange on the 40 mm valve and open the 250 mm valve.

SHP PC	MARK	ASSM PC	DESCRIPTION	LENGTH		SPEC	ID
				FT	IN		
75	104-1		250 MM SERIES 10 VAT VALVE WITH 13.25 DIA CF FLG			SS	PC
2300	104-2		BOLT 3/8-24 (INCLUDES 50 SPARES)	0	1 5/8	*	PE
2300	104-3		WASHER 3/8 DIA (INCLUDES 50 SPARES)			SS	PE
80	104-4		GSKT 13.25 DIA CF			COPPER	PA
			* = SILVER PLATED SS				

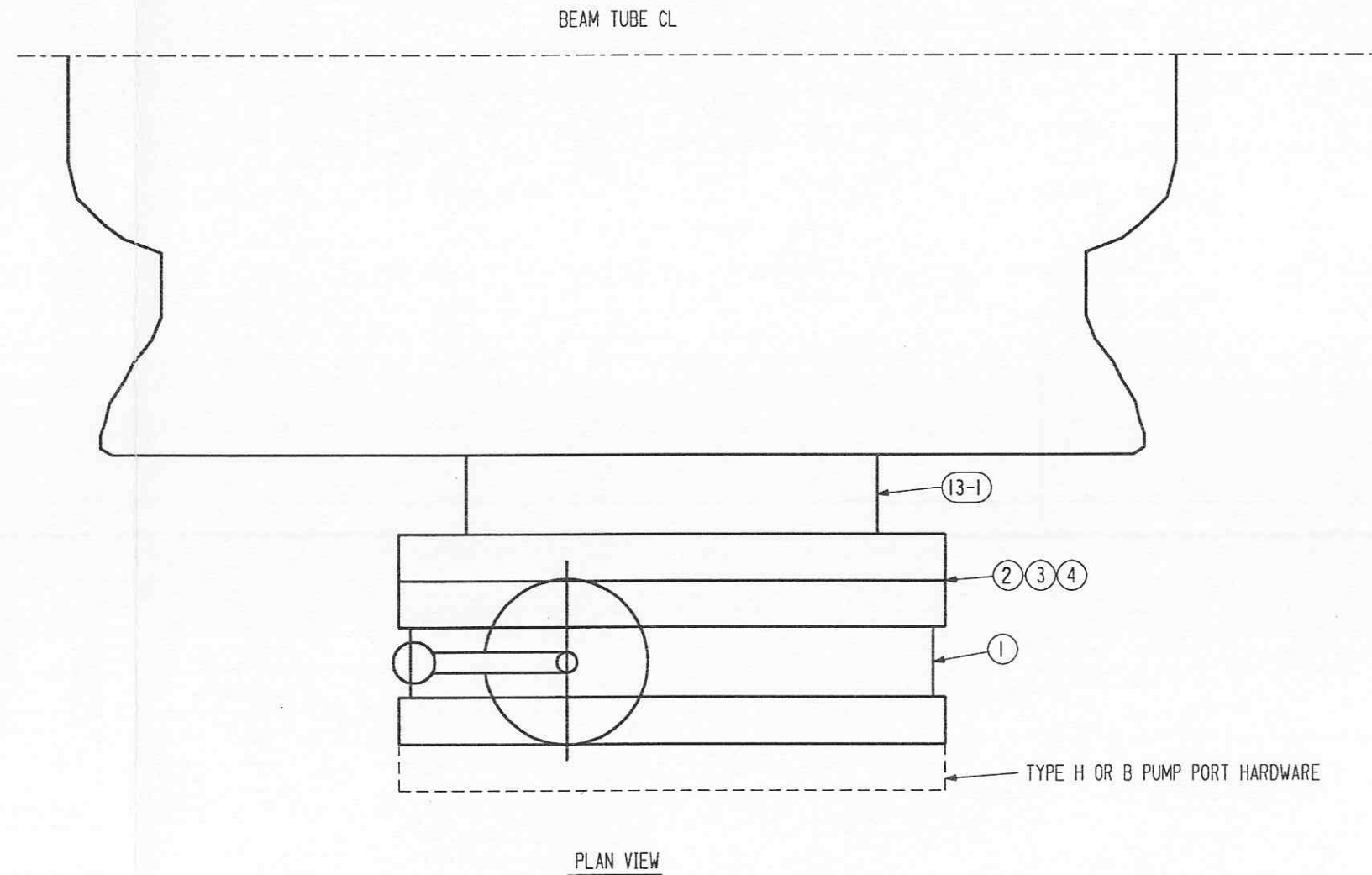

APPROVED	
<i>M. Tellalian</i>	12-6-96
CBI	DATE
<i>J. Jones</i>	12/13/96
CALTECH	DATE

CBI		SUPPLIER'S / PURCHASER'S NO	
LIGO BEAM TUBE HANFORD, WA AND LIVINGSTON, LA			
PUMP PORT ISOLATION VALVE			
CUSTOMER'S NO		CONTRACT NO	
BY DTR	CHKD WAC	DATE 10/2/96	953571
M.J. TELLALIAN		DWG 104	REV
ENGINEERING ASSIGNED		SHT 1	1
L1Q0-D970062-01-B			

INDICATES CHANGE FROM PREVIOUS ISSUE