

REVISIONS			
REV.	DESCRIPTION	APPROVED	DATE
A	RELEASED	AJL	
B	REDRAWN; UPDATED B.O.M.	AJL	11-11-96

(SHOWN IN VALVE CLOSED POSITION)

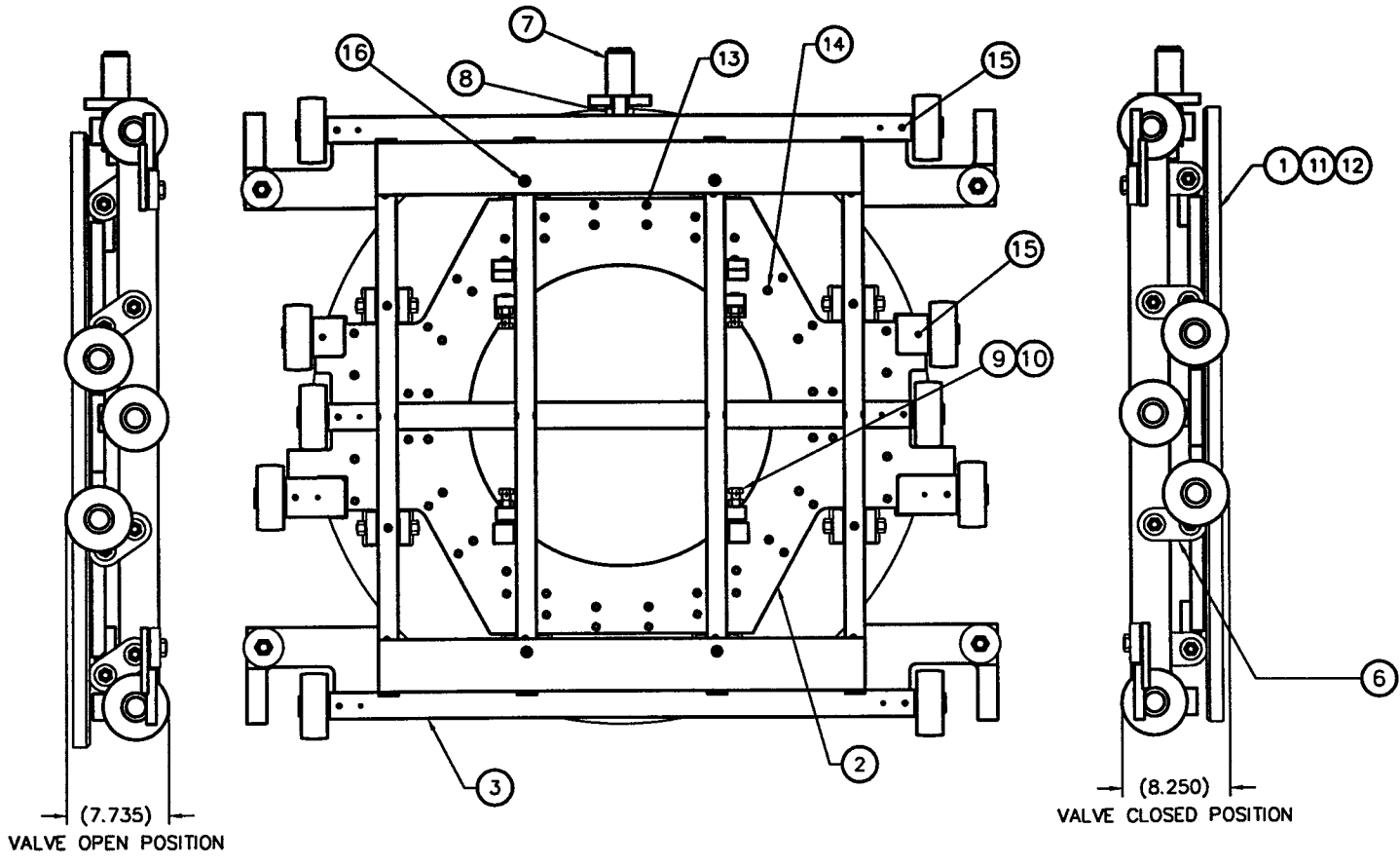
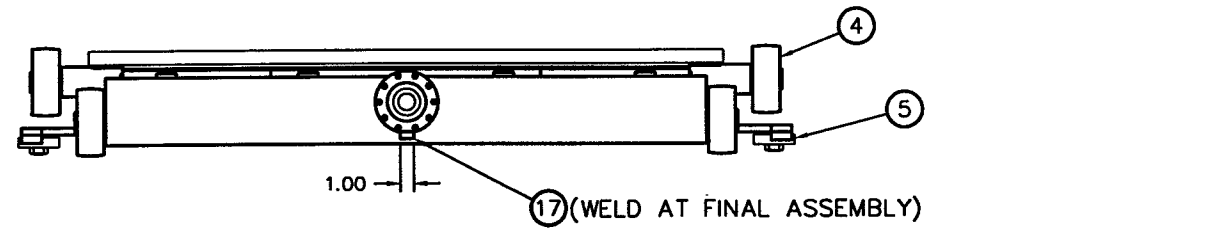

PSI DWG # V049-8-204

L140-D961610-B-V

DEC 19 1996

ITEM	QTY.	PART NO.	DESCRIPTION
17	1	A103799	BLOCK, ANTI-ROTATION
16	8		SSS, 5/16-18 X 1/4, VENTED, SST, SILVER PLATED
15	10		SSS, 5/16-18 X 1/2, VENTED, SST, SILVER PLATED
14	28		SHCS, 1/2-13 X 2, VENTED, SST, SILVER PLATED
13	28		SSS, 1/2-13 X 1 1/4, VENTED, SST, SILVER PLATED
12	1		O-RING, Ø44.75 I.D., 1/4 C/S, VITON, BAKED
11	1		O-RING, Ø44.25 I.D., 1/4 C/S, VITON, BAKED
10	4		HEX JAM NUT, 5/8-11 UNC, SST, SILVER PLATED
9	4	A103806	WELD'T, SCREW, LOCKOVER/COLLAPSE ADJUSTMENT
8	2		CLAMP-TITE COLLAR, (HOLO-KROME) 1 1/4-12,SST
7	1	B103793	WELD'T, CARRIAGE CONNECTING SOCKET
6	8	B103254	LINK ASS'Y
5	4	A103831	GUIDE WHEEL ASS'Y
4	10	A103253	SIDE WHEEL ASS'Y
3	1	D103236	CARRIAGE MACHINING
2	1	D103765	POSTWELD (FINAL) MACHINING, GATE FRAME
1	1	D103227	GATE

PART LIST		MATERIAL SPECIFICATION:	
<small>UNLESS OTHERWISE SPECIFIED DIMENSIONS ARE IN INCHES TOLERANCES AND FINISHES ARE AS SHOWN ON DRAWING UNLESS OTHERWISE SPECIFIED</small>		GNB Corporation SCIENTIFIC AND INDUSTRIAL EQUIPMENT 20871 San Ramon Ct. RAYNARD, CALIFORNIA 94544 (916) 441-1500 FAX: (916) 441-0838	
CONTRACT OR SALES ORDER NO.	1824#	DATE	2-9-96
APPROVALS	DESIGNED BY ZH	CHECKED BY	DATE
DESIGNED BY	ENGINEER	DATE	
DATE FILED	C103255B	SCALE	NONE

D103280
USED ON