

DETAIL "2"
QTY: 2
MAKE FROM V049M163-1

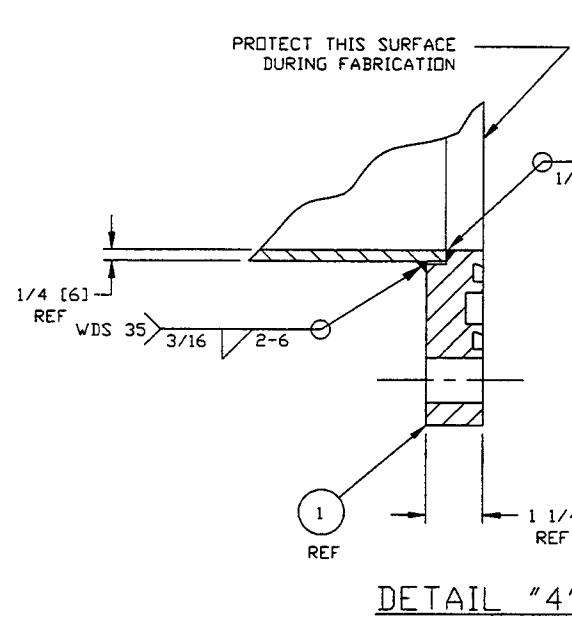

DETAIL "4"

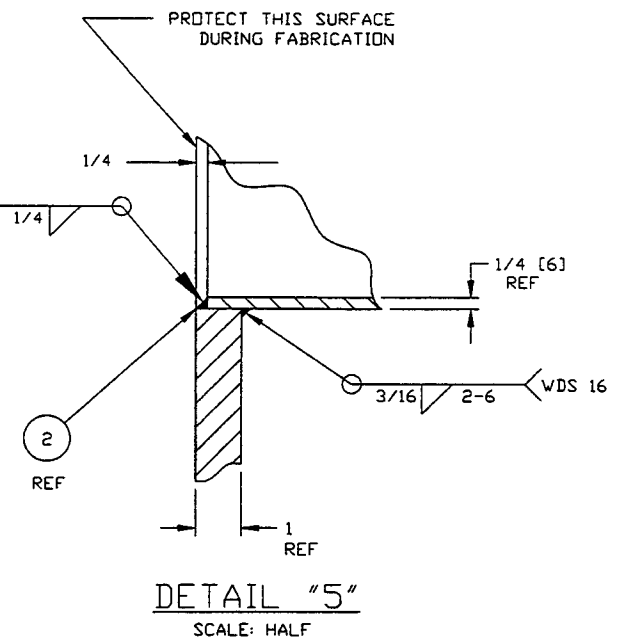

DETAIL "5"
SCALE: HALF

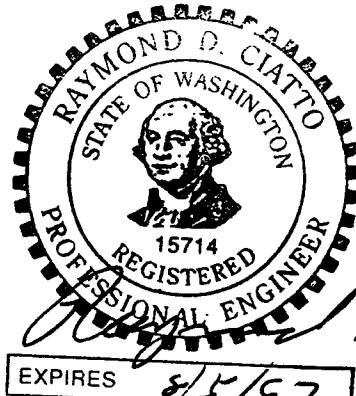

PROCESS SYSTEMS INTERNATIONAL INC. 20 WALKUP DR. WESTBOROUGH, MASSACHUSETTS 01581 USA			
ADAPTER A-3 48.25" ID x 60.50" ID LIGD VACUUM EQUIPMENT			
CAD FILE V049A3/4A3S2	SIZE D	DWG NO. V049-4-A3	REV. 3
SCALE AS NOTED	SHEET 2 OF 2		