

- NOTE:**
- 1: FLANGES WILL BE USED IN ULTRA HIGH VACUUM SERVICE SEE SPECIFICATION V049-2-040 FOR MATERIAL REQUIREMENTS SEE SPECIFICATION V049-2-136 FOR MACHINING REQUIREMENTS
  - 2: ALL MATERIAL TO BE 304L STAINLESS STEEL
  - 3: FLANGES MUST BE PACKAGED, HANDLED, AND SHIPPED IN SUCH A MANNER AS TO MAINTAIN SPECIFIED SURFACE FINISHES AND FLATNESS TOLERANCES.
  - 4: MACHINE TOOL LAY TO BE CONCENTRIC ON ALL SURFACES THAT REQUIRE A 32 RMS FINISH
  - 5: NO ABRASIVE STONES, CLOTHS OR GRINDING WHEELS MAY BE USED.
  - 6: NO OIL BASED OR HYDROCARBON BASED CUTTING FLUIDS TO BE USED.
  - 7: NO CARBON STEEL OR OTHER SOURCE OF IRON CONTAMINATION ARE TO COME IN CONTACT WITH FLANGES DURING MANUFACTURING OR HANDLING.
  - 8: FLANGE FINAL FACE CUTS AND O-RING GROOVES MUST BE MACHINED DURING THE SAME SETUP.
  - 9: STEAM CLEAN & WRAP IN POLYETHYLENE TO PREVENT CONTAMINATION DURING SHIPPING.
  - 10: SCRIBE OUTER EDGE OF FLANGE WITH SCRIBE LINE & METAL STAMP "ANNULUS"
  - 11: DO NOT MACHINE FLANGE O.D. ALL FORGING MANUFACT. NOS. TO BE LEFT INTACT

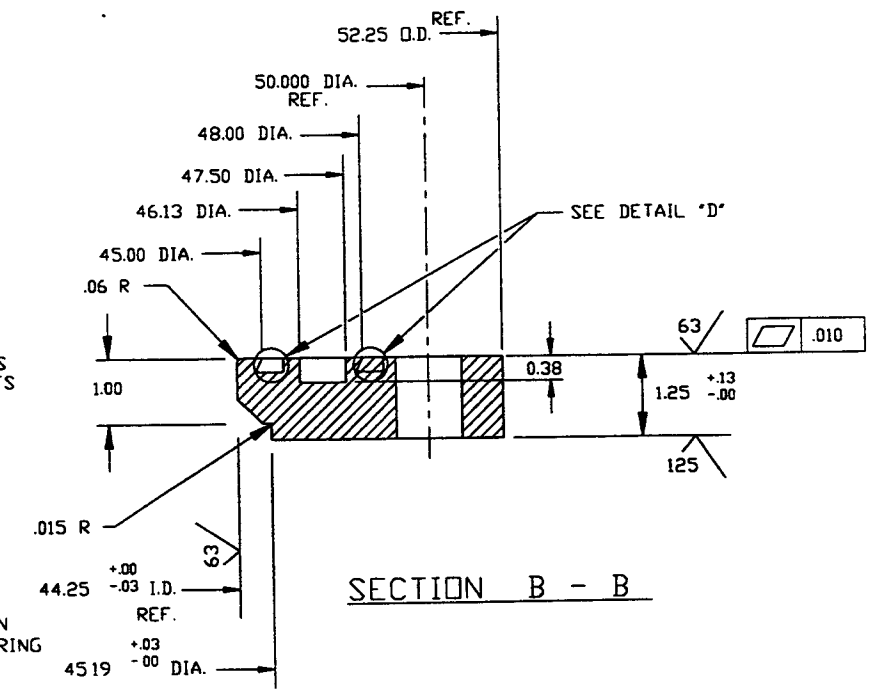

THIS FLANGE TO BE MADE FROM P/N V049M244-1  
WEIGHT: 215#

INNER O-RING .275 DIA. STOCK x 140 3/4" LG. VULCANIZED - BAKED VITON E-60C  
OUTER O-RING .275 DIA. STOCK x 150" LG. VULCANIZED - BAKED VITON E-60C

**PROPRIETARY AND CONFIDENTIAL**  
THIS DOCUMENT CONTAINS PROPRIETARY INFORMATION BELONGING TO PROCESS SYSTEMS INTERNATIONAL, INC. OR ITS AFFILIATED COMPANIES AND SHALL BE USED ONLY FOR THE PURPOSE FOR WHICH IT WAS SUPPLIED. IT SHALL NOT BE COPIED, REPRODUCED OR OTHERWISE USED NOR SHALL SUCH INFORMATION BE FURNISHED IN WHOLE OR IN PART TO OTHERS EXCEPT IN ACCORDANCE WITH THE TERMS OF ANY AGREEMENT UNDER WHICH IT WAS SUPPLIED OR WITH THE PRIOR WRITTEN CONSENT OF PROCESS SYSTEMS INTERNATIONAL, INC. AND SHALL BE RETURNED UPON REQUEST.

DWG. NO.	DESCRIPTION	USED ON:	NEXT ASS'Y:
	REFERENCE DRAWINGS		

UNLESS OTHERWISE SPECIFIED DIMENSIONS ARE IN INCHES TOLERANCES:  
FRACTIONAL ± 1/16  
ANGULAR APPROX ± 30' BEH ± 2"  
TWO PLACE DECIMAL ± .010  
THREE PLACE DECIMAL ± .005  
FINISHED SURFACE RMS 32  
BREAK CHORDS .040 DIA. OUT .005 REMOVE ALL BURRS  
DO NOT SCALE THIS DWG.

REV.	DESCRIPTION	CHKD	DRAWN	DATE	DEC
3	REISSUED FOR FABRICATION / FDR UPDATE				
2	REISSUED FOR FABRICATION	GS	PEF	DMV	RDC REC
1	RELEASED FOR FAB	GS	PEF	DMV	RDC REC
0	ISSUED FOR FDR				
P3	PRELIMINARY				
P2	PRELIMINARY				

CAD FILE	SIZE	DWG. NO.	REV.
V0494017	C	V049-4-017	3

SCALE 1 1/2"=1'-0" SHEET 1 OF 1