

REV.	DATE	DCN #	DRAWING TREE #
A	6 AUG 2008	E080420-00-D	

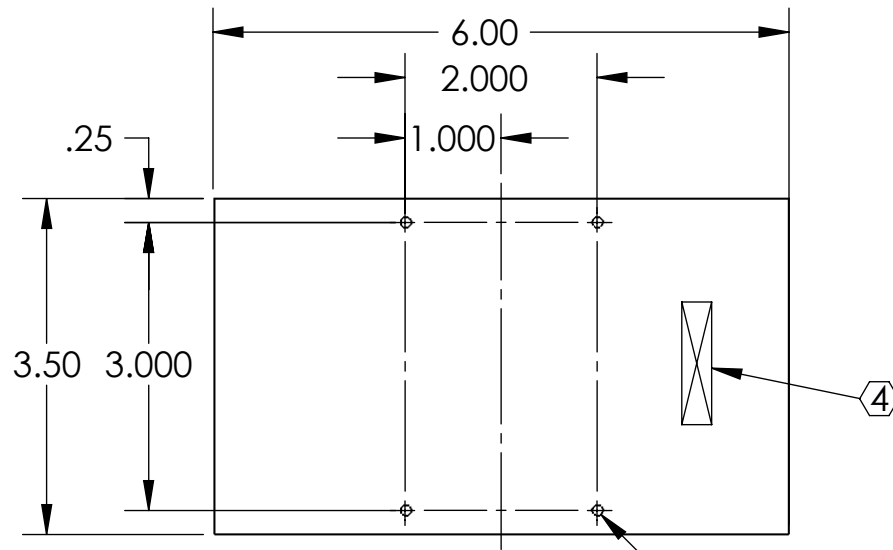

4X 4-40 UNC - 2B THRU  
+.005 OVERSIZE TAP

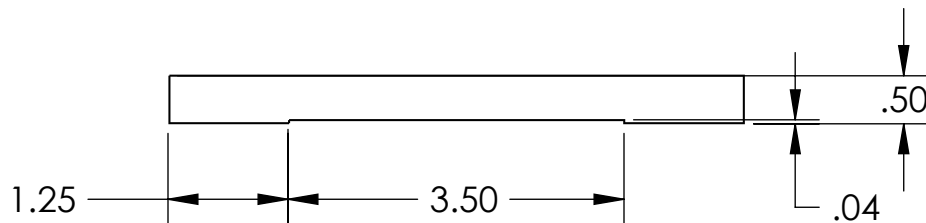

**NOTES: (UNLESS OTHERWISE SPECIFIED)**

- DO NOT SCALE FROM DRAWING.
- REMOVE ALL SHARP EDGES, R.02 MAX.
- ALL MACHINING FLUIDS SHALL BE WATER SOLUBLE AND FREE OF SULFUR, CHLORINE AND SILICONE.

④ SCRIBE, ENGRAVE OR MECHANICALLY STAMP DRAWING (NO INKS OR DYES) PART NUMBER, REVISION ON NOTED SURFACE OF PART FOLLOWED ON THE NEXT LINE WITH A THREE DIGIT SERIAL NUMBER. SERIAL NUMBERS START AT 001 FOR THE FIRST ARTICLE AND PROCEED CONSECUTIVELY. USE .12" HIGH CHARACTERS, UNLESS THE SIZE OF THE PART DICTATES SMALL CHARACTERS. A VIBRATORY TOOL MAY BE USED. EXAMPLE:  
D050XXX-A  
S/N 001

DIMENSIONS ARE IN INCHES

TOLERANCES:

.XX ± 0.03

.XXX ± 0.005

ANGULAR ± 0.5 °

**MATERIAL**

6061-T6 AL

**FINISH**

63 μ inch

	NAME	DATE
<b>DRAWN</b>	M. MEYER	24 JUL 2008
<b>CHECKED</b>	J. ROMIE	4 AUG 2008
<b>APPROVED</b>		



**SYSTEM** ADVANCED LIGO

**SUB-SYSTEM** SUS

**NEXT ASSY** TT STRUCTURE ASSY

**PART NAME** BASE SHIM (0.5 INCH)

**SIZE** **DWG. NO.** D080451

**REV.** A

**SCALE:** 1:2 **PROJECTION:** **SHEET 1 OF 1**