

REV.	DATE	DCN #	DRAWING TREE #
A	4 AUG 2008	E080419-00-D	
B	6 AUG 2008	E080420-00-D	

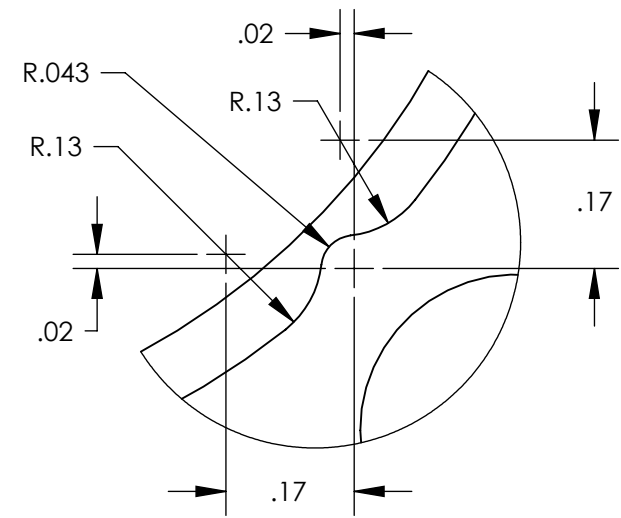

DETAIL A  
SCALE 4 : 1  
(x2)

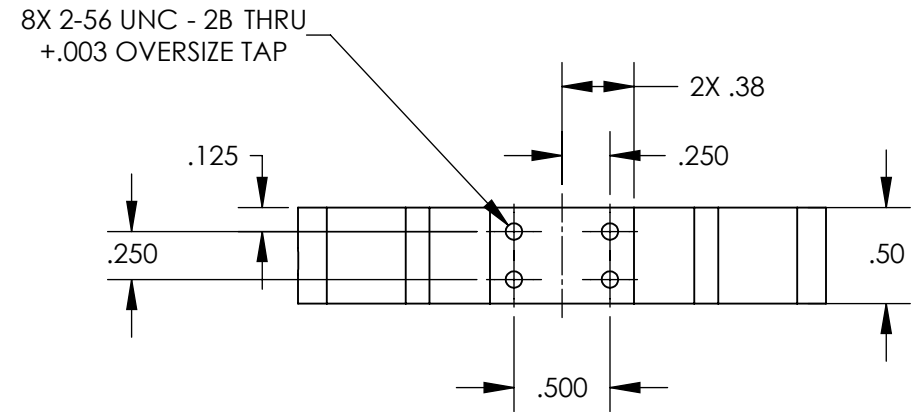
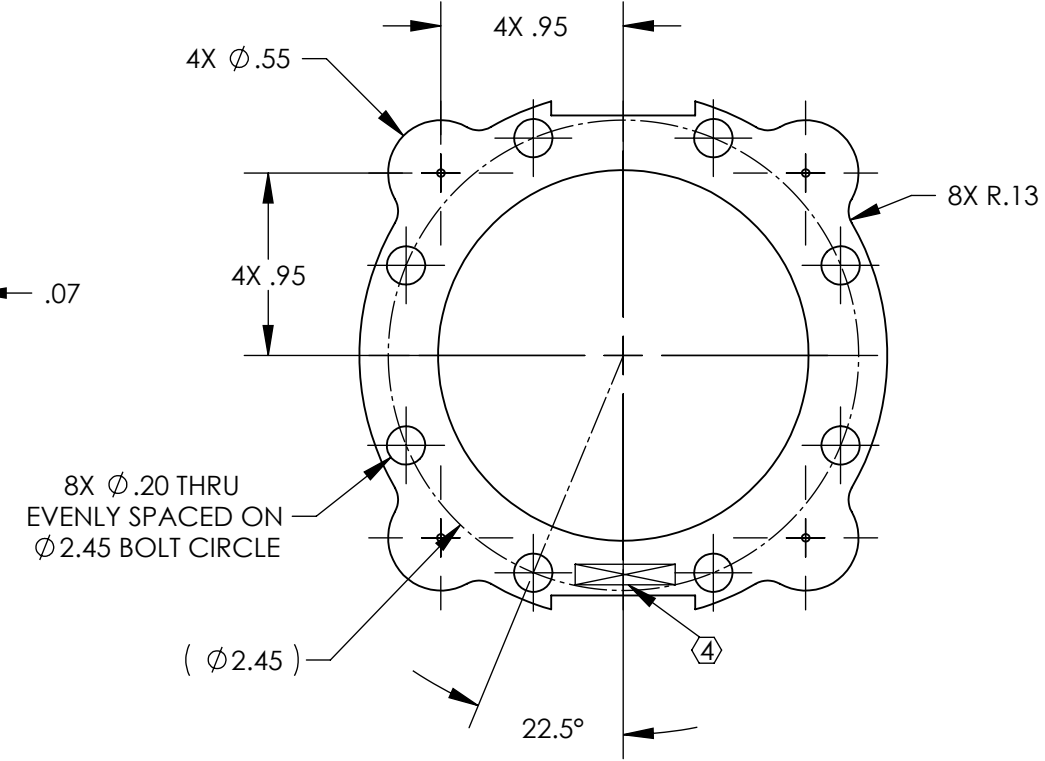
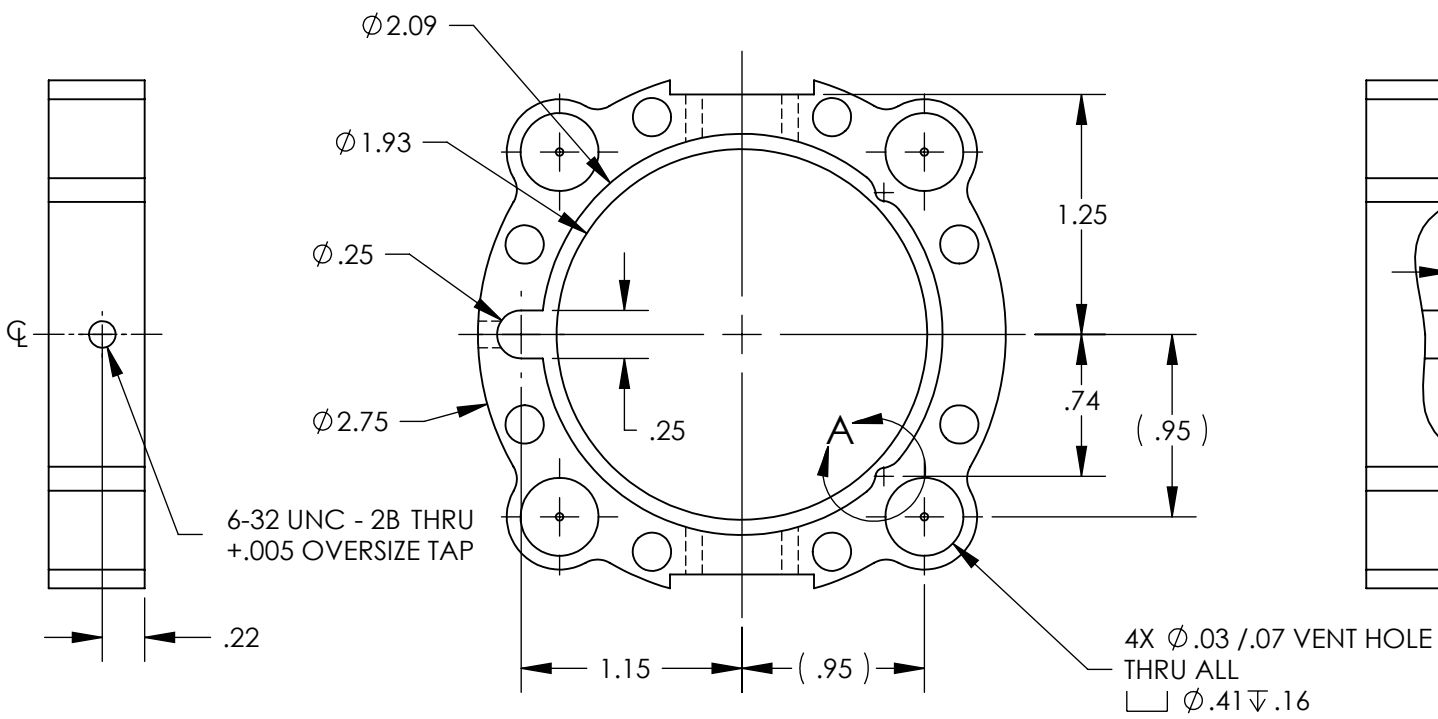
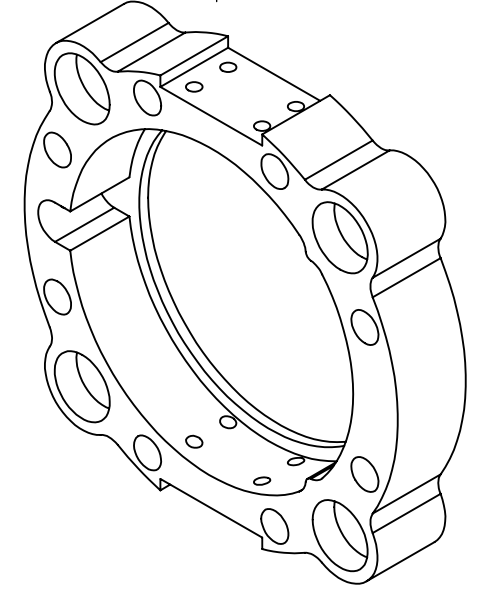

PARTS LIST									
<b>NOTES: (UNLESS OTHERWISE SPECIFIED)</b> 1. REMOVE ALL SHARP EDGES, R.02 MIN. 2. DO NOT SCALE FROM DRAWING. 3. ALL MACHINING FLUIDS SHALL BE WATER SOLUBLE AND FREE OF SULFUR, CHLORINE AND SILICONE, SUCH AS CINCINNATI MILACRON'S CIMTECH 410 (STAINLESS STEEL) ④ SCRIBE, ENGRAVE OR STAMP DRAWING PART NUMBER ON NOTED SURFACE OF PART AND A THREE DIGIT SERIAL NUMBER. SERIAL NUMBERS START AT 001 FOR THE FIRST PART AND PROCEED CONSECUTIVELY. USE .07" HIGH CHARACTERS. EXAMPLE: D020188-001. A VIBRATORY TOOL MAY BE USED.		DIMENSIONS ARE IN INCHES TOLERANCES: .XX ± 0.01 .XXX ± 0.005 ANGULAR ± 0.5°							
MATERIAL <b>6061-T6 AL</b>		FINISH <b>63 µ inch</b>							
<table border="1"> <thead> <tr> <th>NAME</th> <th>DATE</th> </tr> </thead> <tbody> <tr> <td>M. MEYER</td> <td>07 JAN 2008</td> </tr> <tr> <td>J. ROMIE</td> <td>4 AUG 2008</td> </tr> </tbody> </table>		NAME	DATE	M. MEYER	07 JAN 2008	J. ROMIE	4 AUG 2008	SYSTEM <b>ADVANCED LIGO</b>	
NAME	DATE								
M. MEYER	07 JAN 2008								
J. ROMIE	4 AUG 2008								
SUB-SYSTEM <b>SUS</b>		NEXT ASSY <b>TT MIRROR ASSEMBLY</b>							
PART NAME <b>2" MIRROR HOLDER</b>		SIZE DWG. NO. <b>B D080069</b>							
SCALE: 1:1		PROJECTION:							
SHEET 1 OF 1		REV. <b>B</b>							