

REV.	DATE	DCN #	DRAWING TREE #
00	NOV 07	INITIAL RELEASE (R.JONES)	

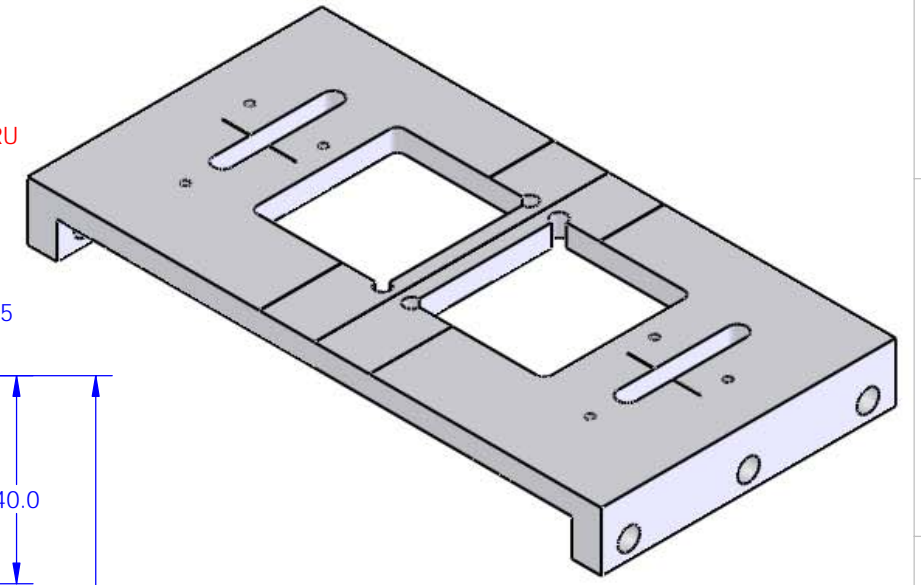
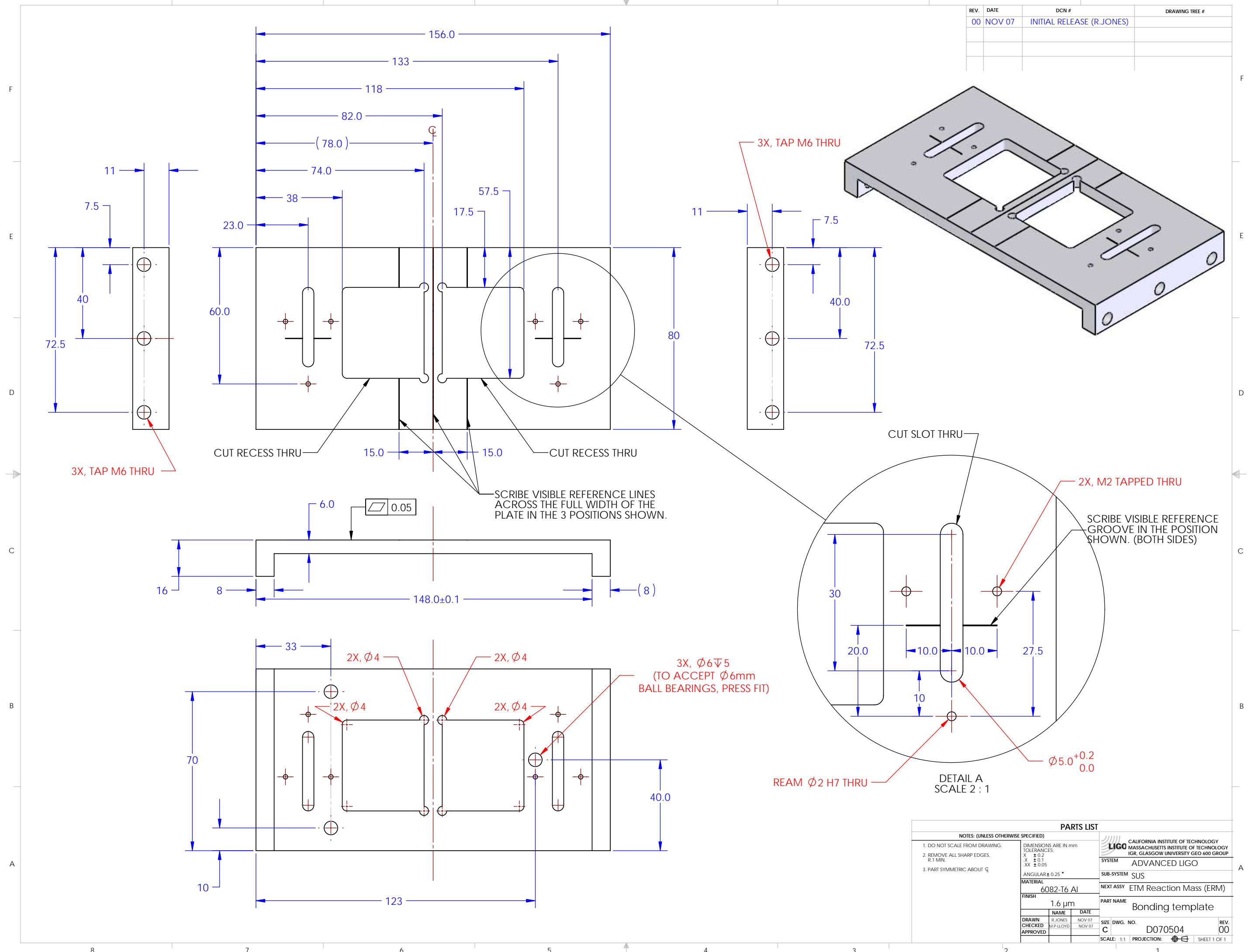

NOTES: (UNLESS OTHERWISE SPECIFIED)		PARTS LIST	
1. DO NOT SCALE FROM DRAWING.	DIMENSIONS ARE IN mm	CALIFORNIA INSTITUTE OF TECHNOLOGY MASSACHUSETTS INSTITUTE OF TECHNOLOGY IGR, GLASGOW UNIVERSITY GEO 600 GROUP SYSTEM ADVANCED LIGO SUB-SYSTEM SUS NEXT ASSY ETM Reaction Mass (ERM) PART NAME Bonding template	
2. REMOVE ALL SHARP EDGES, R1 MIN.	TOLERANCES:		
3. PART SYMMETRIC ABOUT $\phi$ .	X ± 0.2		
	X ± 0.1		
	XX ± 0.05	MATERIAL 6082-T6 Al	SIZE DWG. NO. D070504
	ANGULAR ± 0.25 °	FINISH 1.6 µm	REV. 00
			SCALE: 1:1 PROJECTION:
			SHEET 1 OF 1