

Last Edited: 31 October 2006

Title OMC Piezo Driver Overview		LIGO Laboratory California Institute of Technology Massachusetts Institute of Technology		LIGO	
Size: B	DCC Number: D060283	Revision: B	Engineer: R. Abbott	Date: 3/14/2007	Time: 1:57:31 PM
File: C:\Rich's Files\Mycadfiles\ISC\DC_readout\PiezoDriver\OMC_overview_b.SchDoc					Sheet 1 of 4

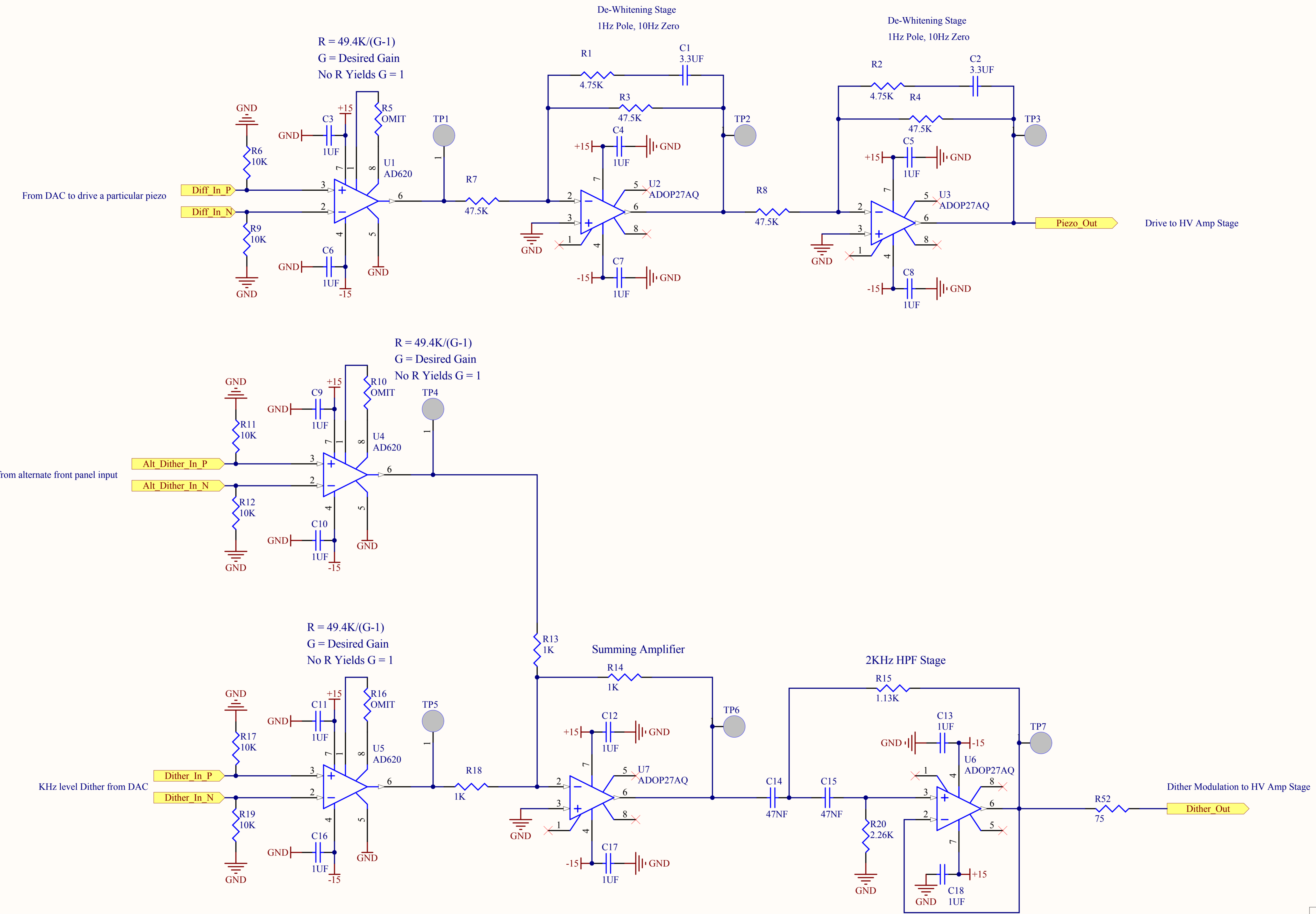

Last Edited: 31 October 2006

Title		LIGO Laboratory California Institute of Technology Massachusetts Institute of Technology		LIGO	
Size: B	DCC Number: D060283	Revision: B	Engineer: R. Abbott	Date: 3/14/2007	Time: 1:57:31 PM
File: C:\Rich's Files\Mycadfiles\ISC\DC_readout\PiezoDriver\diff_rec_OMC_b.SchDoc					Sheet 2 of 4

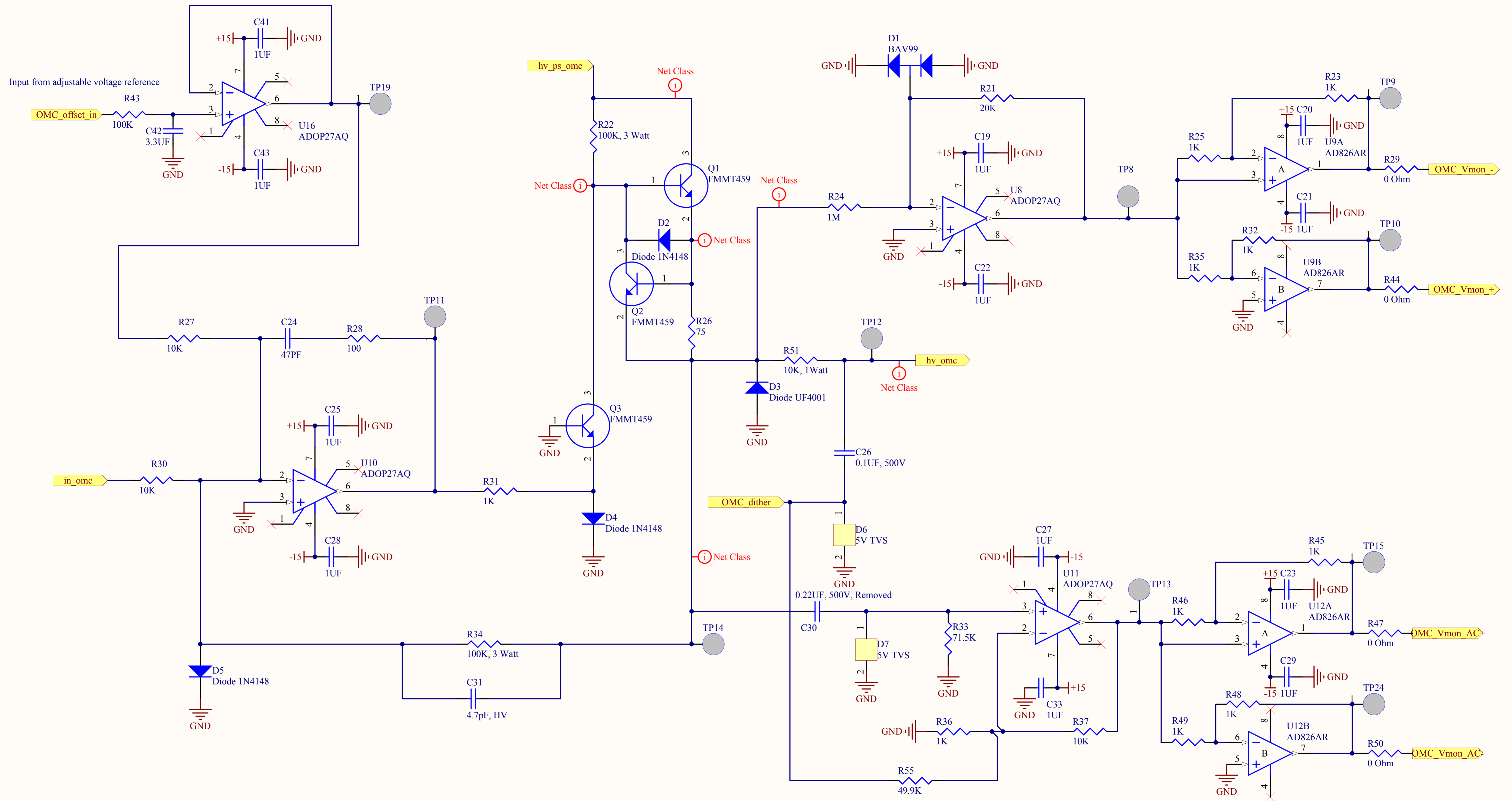

Last Edited: 31 October 2006

Title		LIGO Laboratory California Institute of Technology Massachusetts Institute of Technology		LIGO	
Size: B	DCC Number: D060283	Revision: B	Engineer: R. Abbott	Date: 3/14/2007	
File: C:\Rich's Files\MyCADfiles\ISC\DC_readout\PiezoDriver\HV_driver_b.SchDoc				Time: 1:57:31 PM	
				Sheet 3 of 4	

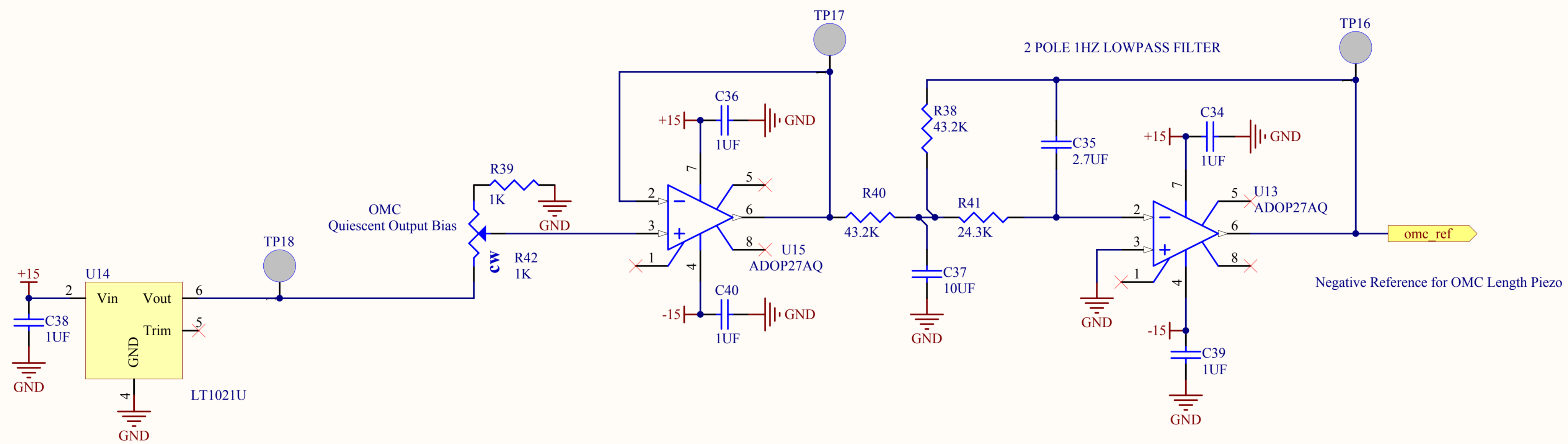

Last Edited: 31 October 2006

Title		LIGO Laboratory California Institute of Technology Massachusetts Institute of Technology		LIGO	
Size: B	DCC Number: D060283	Revision: B	Engineer: R. Abbott	Date: 3/14/2007	Time: 1:57:31 PM
File: C:\Rich's Files\Mycadfiles\ISC\DC_readout\PiezoDriver\ref_filter_OMC_b.SchDoc					Sheet 4 of 4

D060283 Rev. B Piezo Driver SN

