

section A-A
scale 1/1
typical

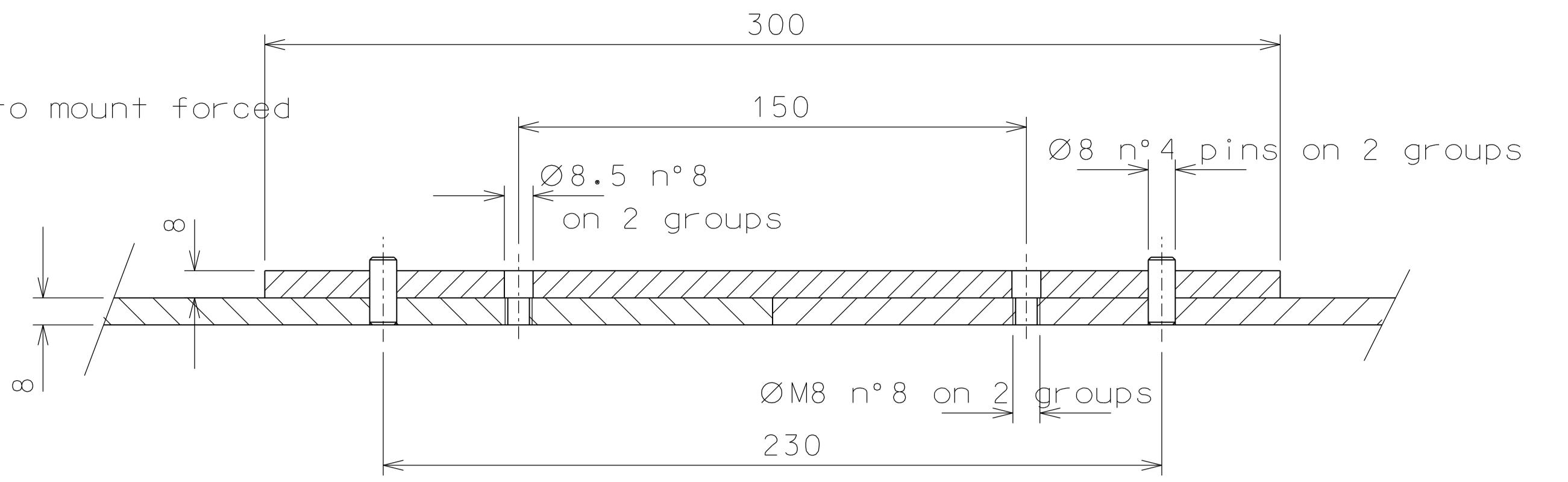

section D-D
scale 1/2.5
typical

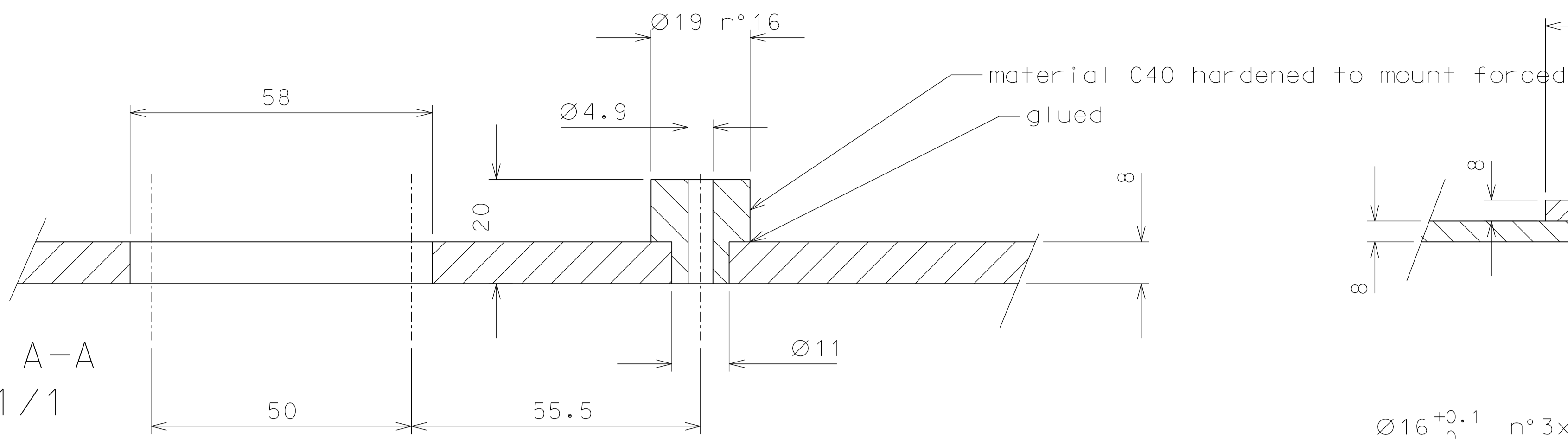
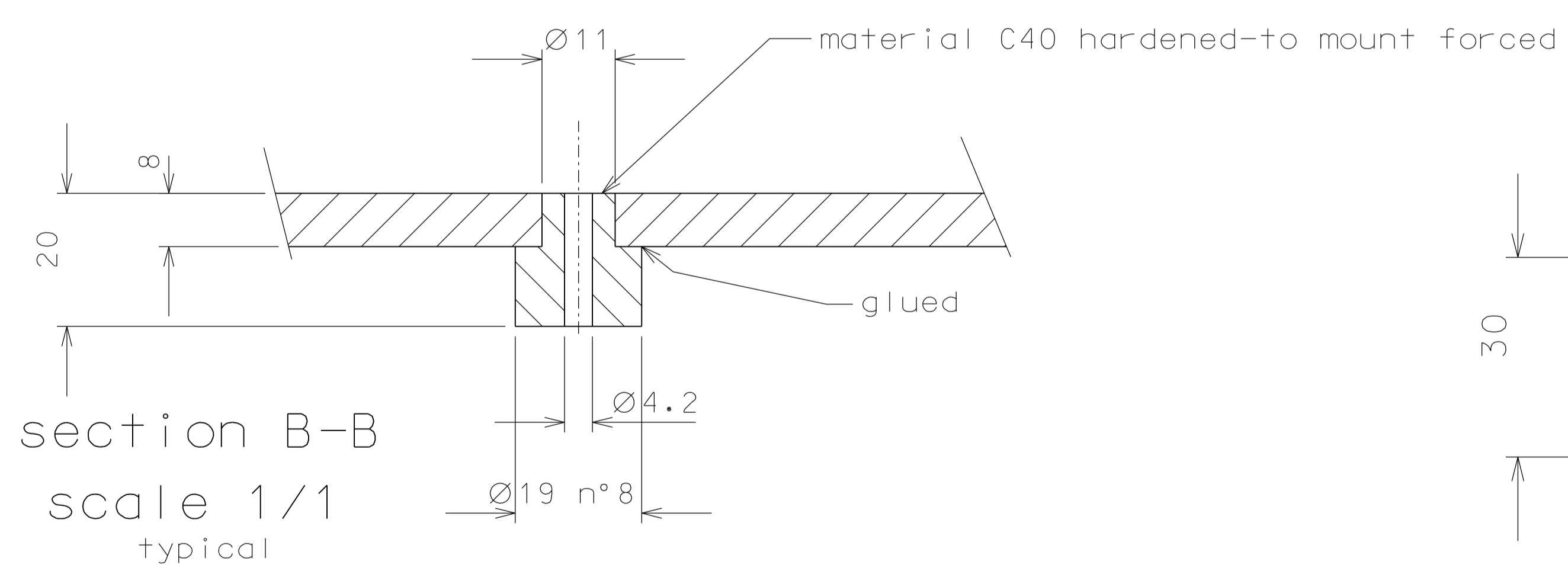
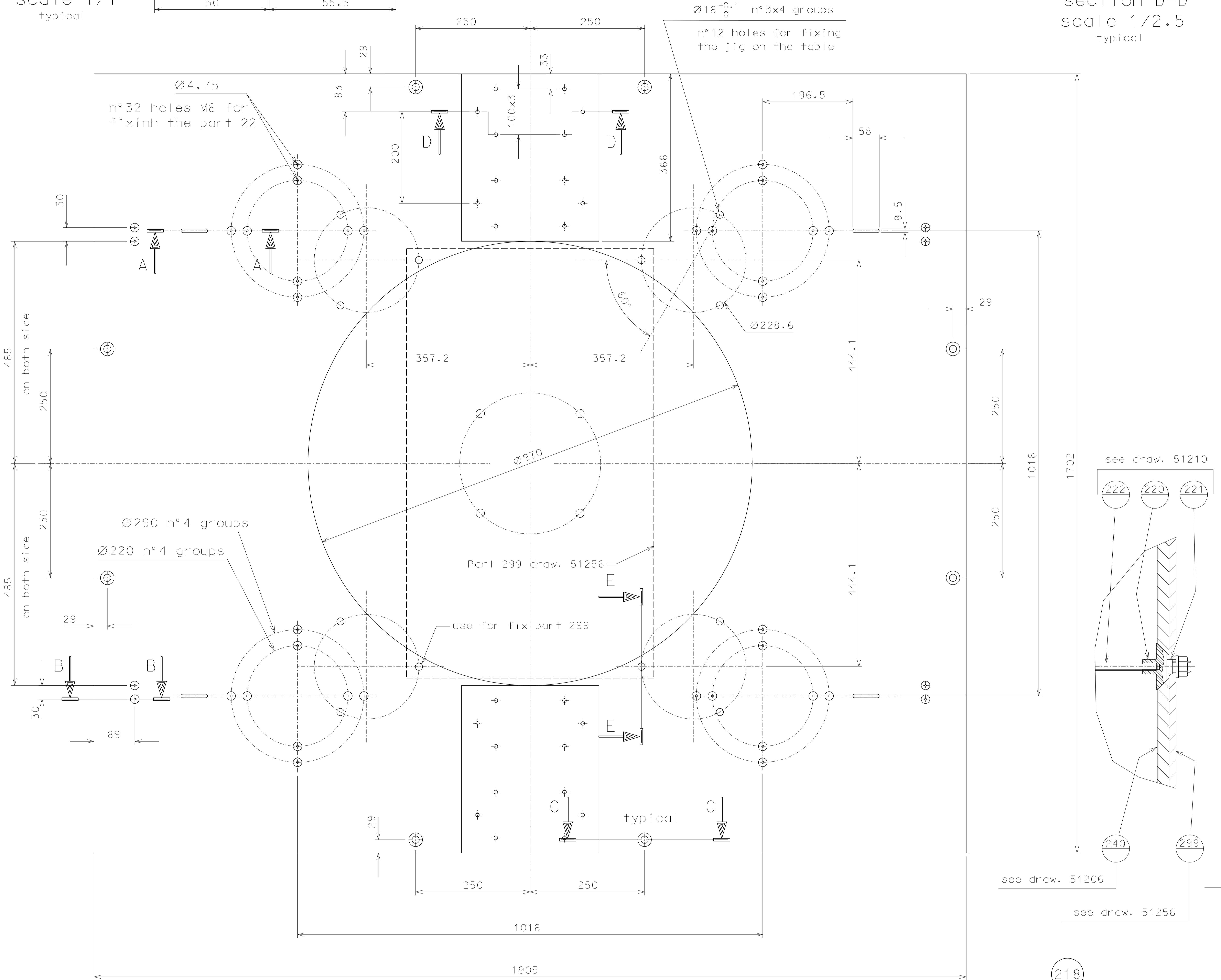

section B-B
scale 1/1
typical

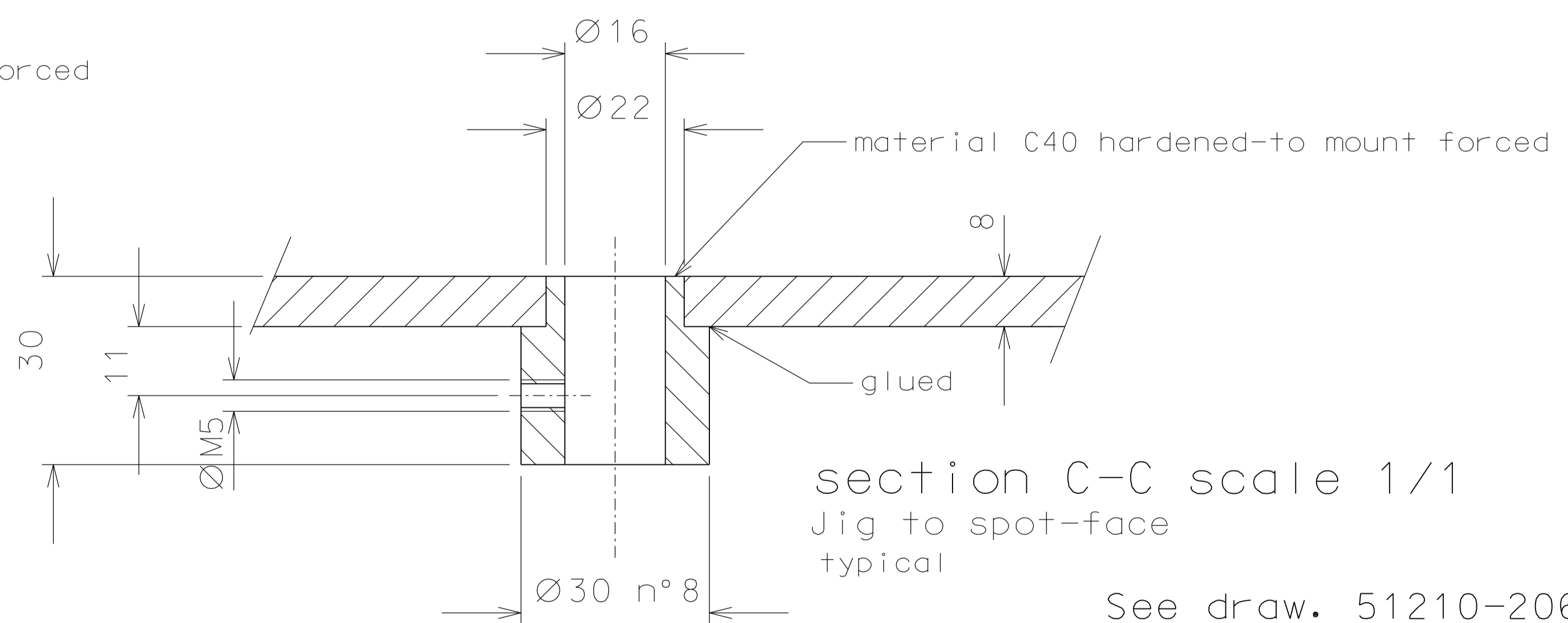

section C-C scale 1/1
Jig to spot-face
typical

See draw. 51210-206-256

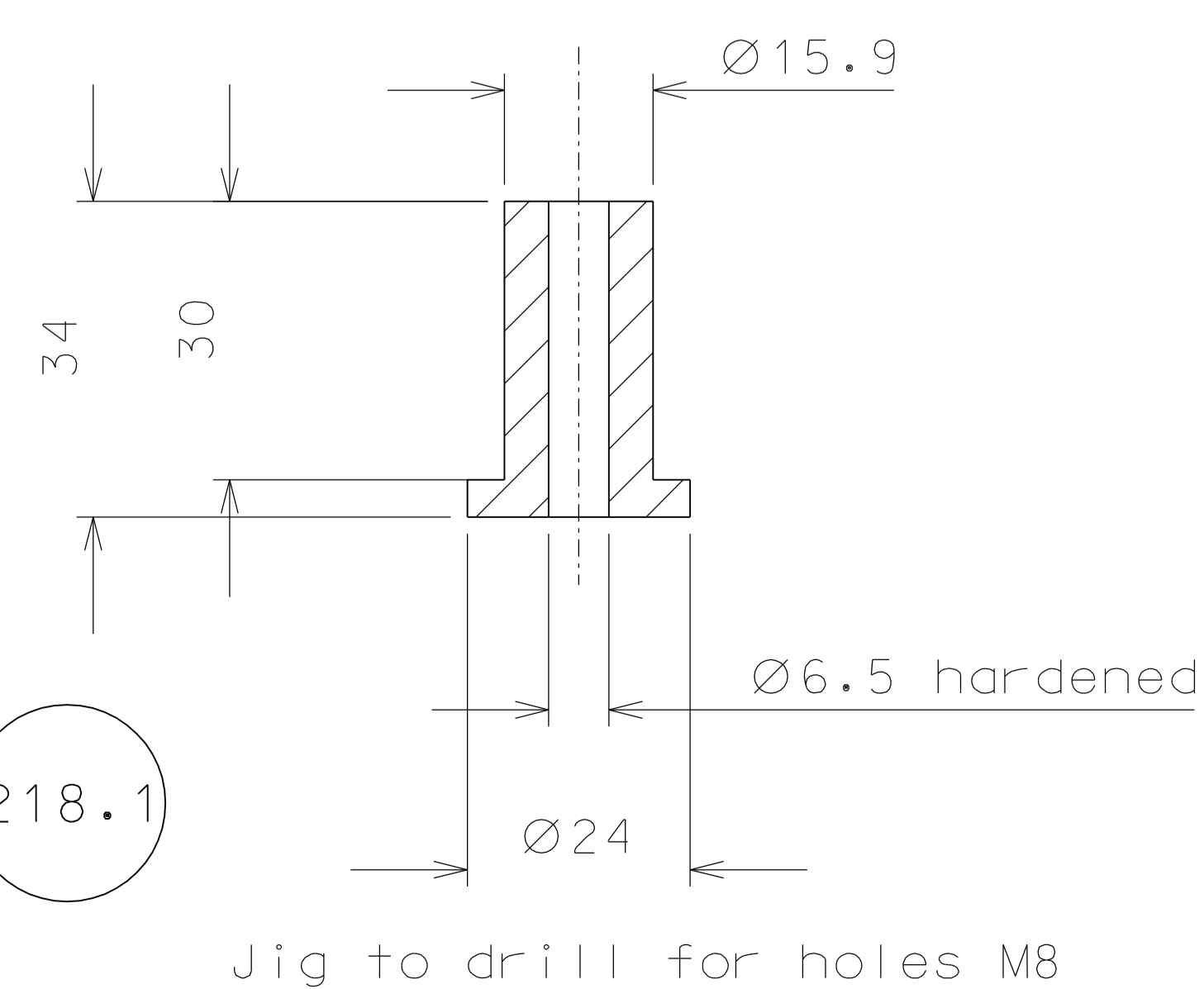
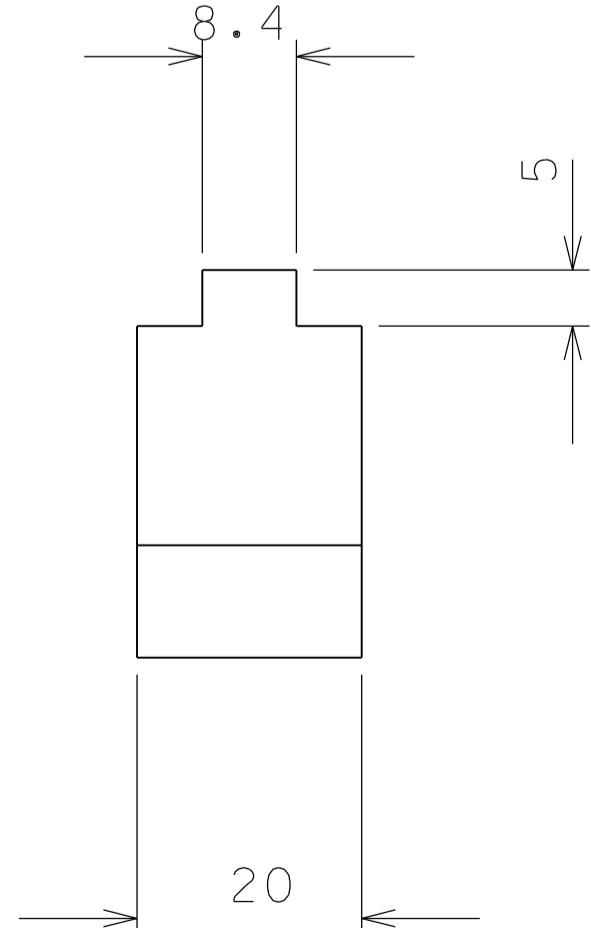
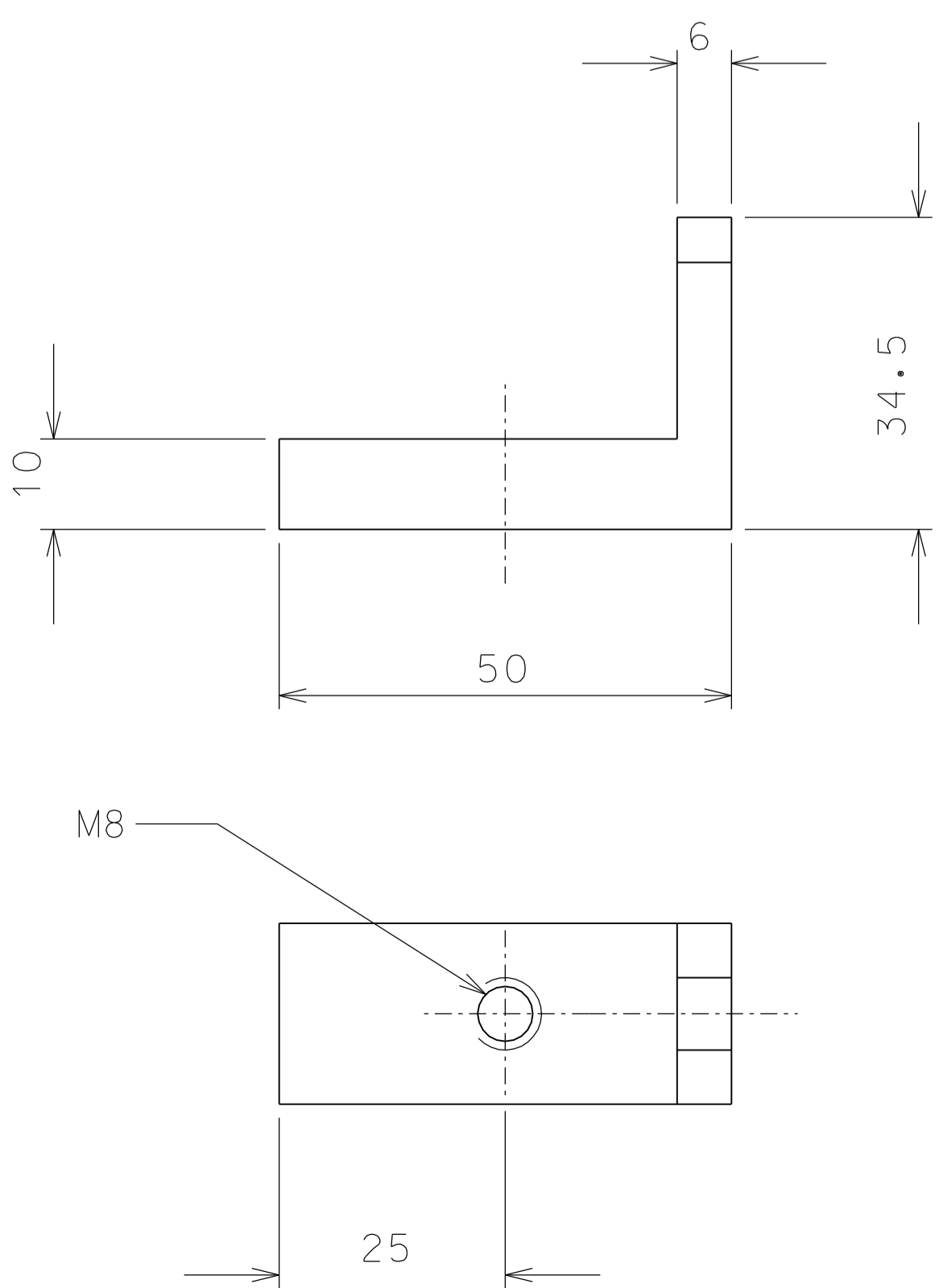

Jig to drill for holes M8

added assembly view	12-11-06		
separate in two parts	04-05-06		
added n° parts of sect. B-B	28-04-06		
ref.	note	date	signature
modifications			
219	4	EN 6082	1/1
218.1	8	C40 hardened	1/5
218	1	EN 6082	1/5
ref.	pieces	mat. and treatments	scale
General machining tolerances UNI 5307-63			
Dimensions	< 6	> 6-30	> 30-120
Linear Toli.	± 0.1	± 0.2	± 0.3
angular Toli.	± 1'	± 30'	± 20'
designed for R.De Salvo			
draw. by C.Gennaro-PRMEC		date 9-02-06	scale 1/5
title HAM-OPTICAL BENCH		LIGO-D051209-03-D	
JIG TO DRILL OLD TABLE		detail from	A 1