

REV.	DATE	DCN #	DRAWING TREE #
A	MAR 23 2006	E060057-00	E060059-A

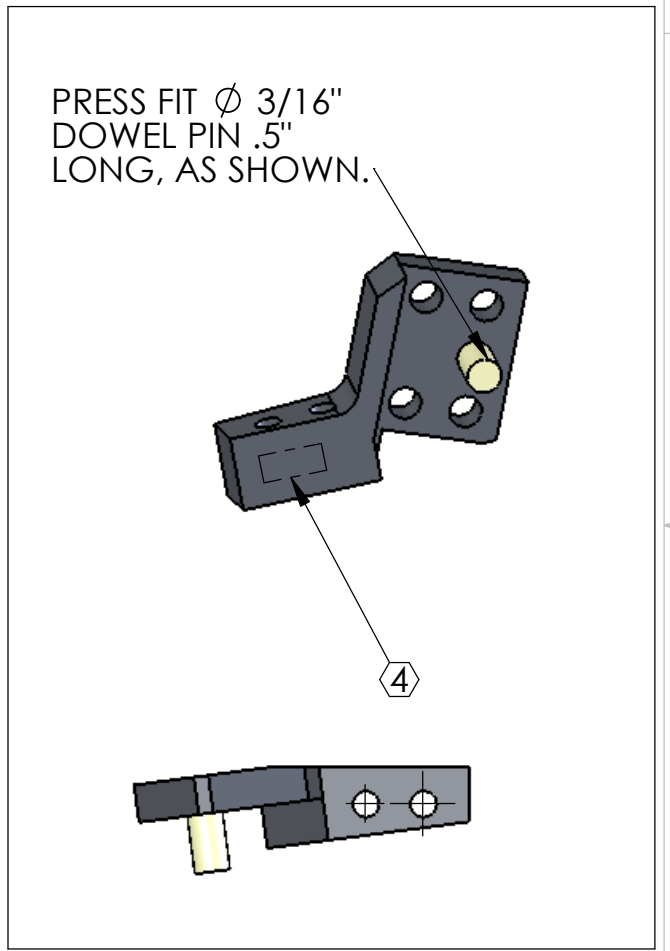
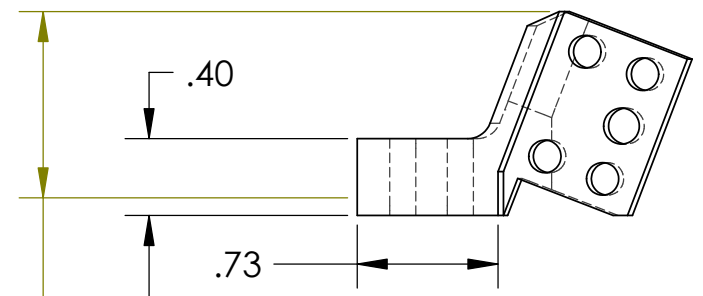
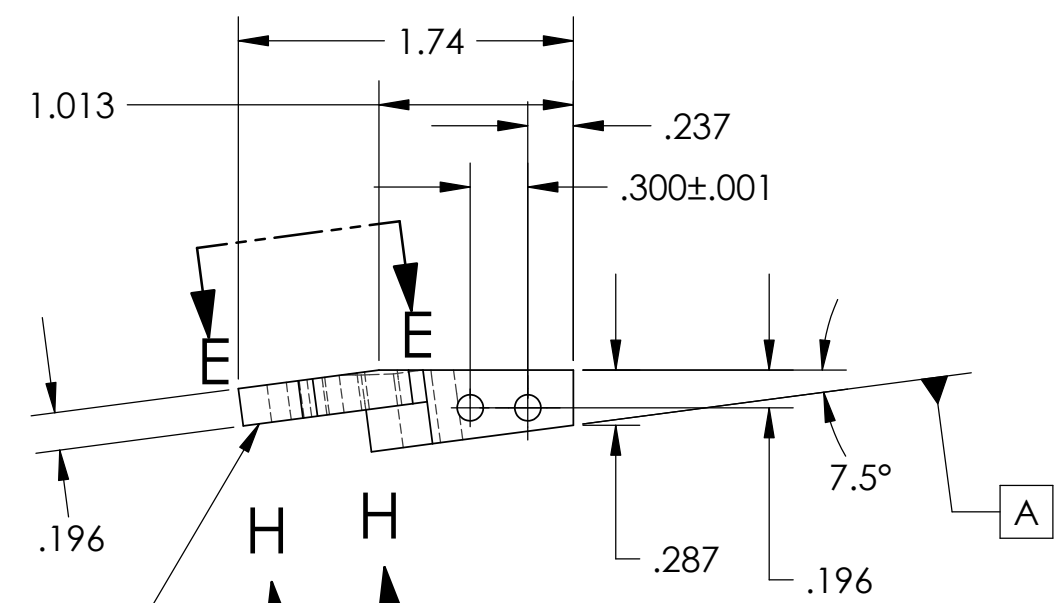
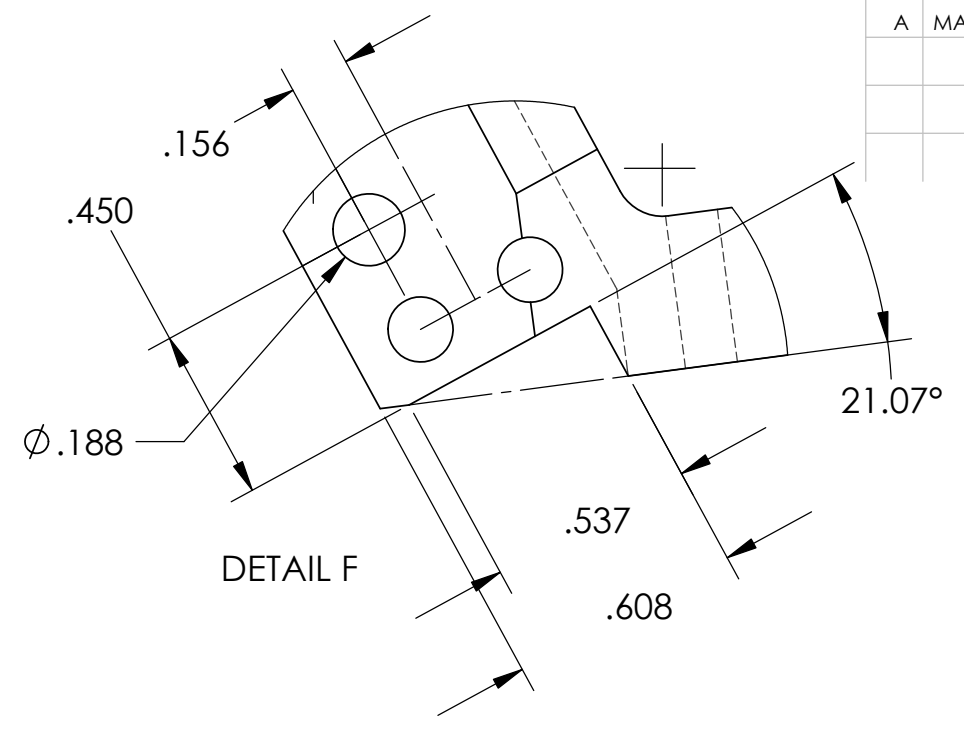
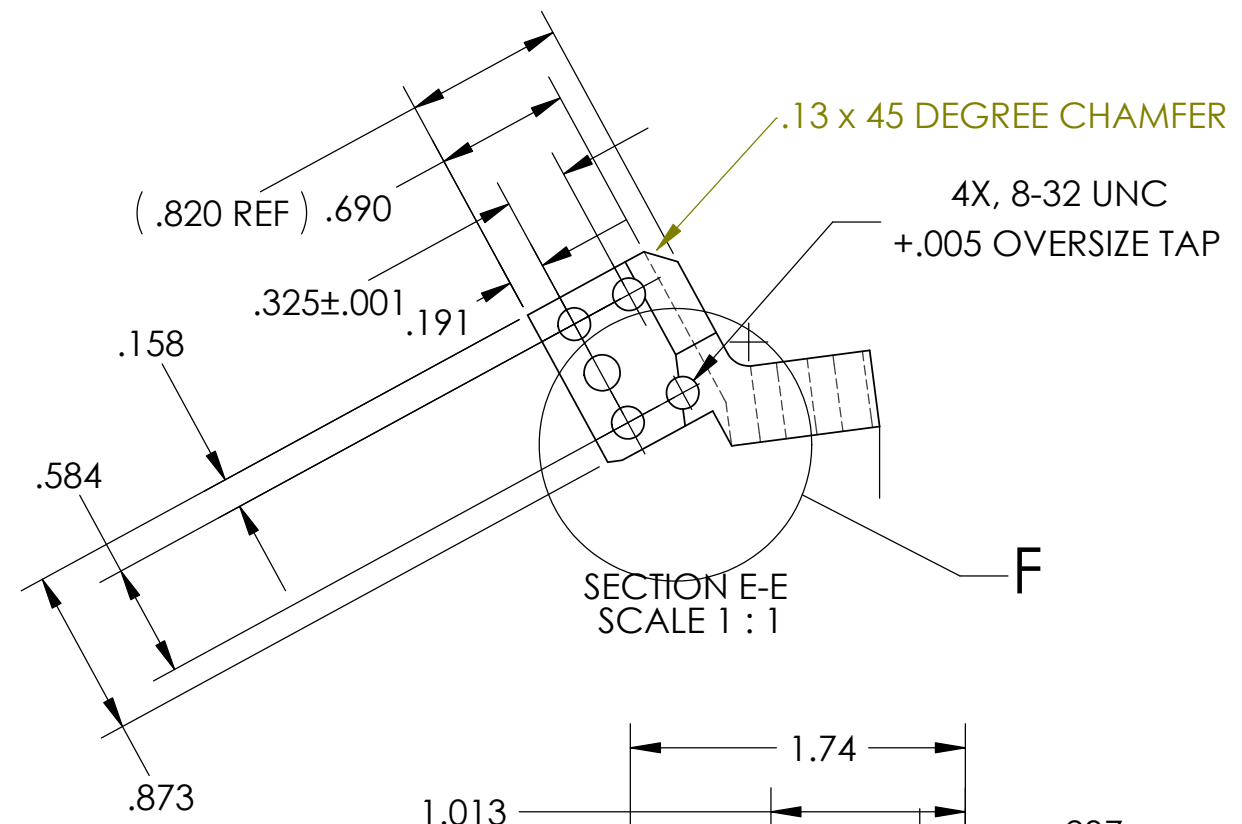

NOTES: (UNLESS OTHERWISE SPECIFIED)		PARTS LIST	
1. DO NOT SCALE FROM DRAWING. 2. REMOVE ALL SHARP EDGES, R.02 MAX. 3. ALL MACHINING FLUIDS SHALL BE WATER SOLUBLE AND FREE OF SULFUR, CHLORINE AND SILICONE. 4. SCRIBE, ENGRAVE OR MECHANICALLY STAMP DRAWING (NO INKS OR DYES) PART NUMBER, REVISION ON NOTED SURFACE OF PART FOLLOWED ON THE NEXT LINE WITH A THREE DIGIT SERIAL NUMBER. SERIAL NUMBERS START AT 001 FOR THE FIRST ARTICLE AND PROCEED CONSECUTIVELY. USE .12" HIGH CHARACTERS, UNLESS THE SIZE OF THE PART DICTATES SMALL CHARACTERS. A VIBRATORY TOOL MAY BE USED, EXAMPLE: D050XXX-A S/N 001		DIMENSIONS ARE IN INCHES TOLERANCES: .XX ± 0.01 .XXX ± 0.005 ANGULAR ± 0.5°	
MATERIAL 300 SSSL		FINISH µ inch	
DRAWN C TORRIE 15 AUG 2005		NAME TOP BLADE	
CHECKED J ROMIE 15 AUG 2005		DATE 15 AUG 2005	
APPROVED [Signature]		PART NAME TOP BLADE WIRE CLAMP BODY CPAD	
SIZE B		DWG. NO. D050328	
SCALE: NTS		PROJECTION: [Symbol]	
SHEET 1 OF 1		REV. A	

[24.64]
.97