

see drawing 027 (2)

(39) see drawing 037

(93)

(29) see drawing 035

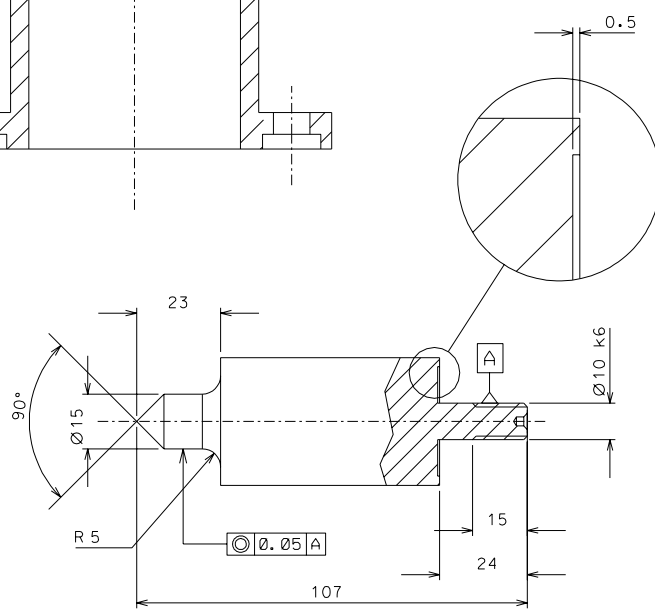
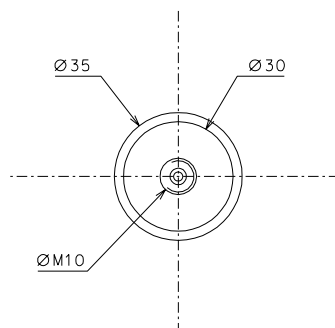

(93) nickel plated

NOTE: The details 93 and 30 must be aligned and slip fit with the details 71, 67, 29
 Note: Lock screws to align part 2 with part 4

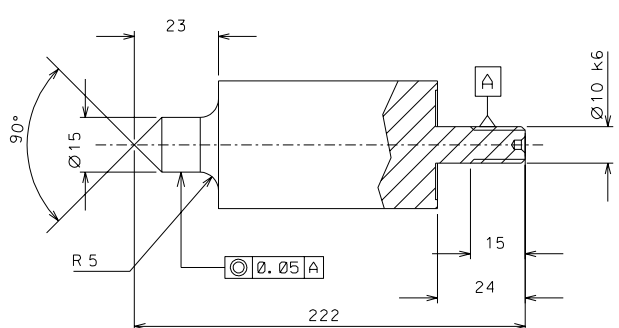

(93.1) nickel plated

ref.	pieces	mat. and treatments	scale	ref.	pieces	mat. and treatments	scale
93.1	4	C40	1/1				
93	4	C40	1/1				

General machining tolerances UNI 5307-63							
Dimensions	< 6	>6-30	>30-120	>120-315	>315-1000	>1000-2000	>2000-4000
Linear Toli.	±0.1	±0.2	±0.3	±0.5	±0.8	±1.2	±2
angular Toli.	±1	±30'	±20'	referred to the shortest side			

designed for	R.De Salvo		
draw. by	G. Gennaro-PROMECC		
date	29-01-05	scale	1/1
title	HAM-OPTICAL BENCH MOUNTING TOP PLATE TOOL		
detail from	LIGO-D050148-01-D		A 2