

8

7

6

5

4

3

2

1

LTR		ZONE		REVISIONS										DWN	CHK	ENGR	STRESS	MATL	THRM	ME	PROJ	QA	RELEASE DATE	
A				INITIAL RELEASE																				

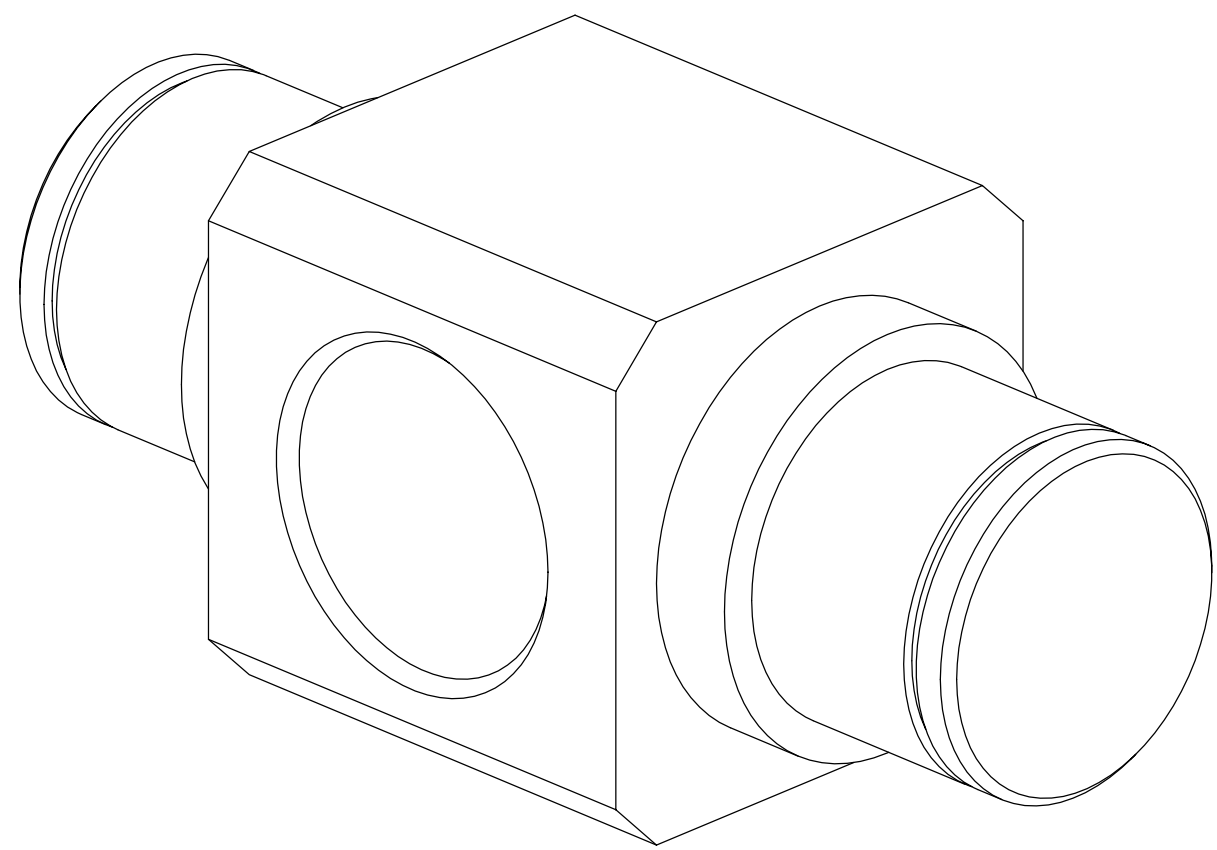

REFERENCE ONLY

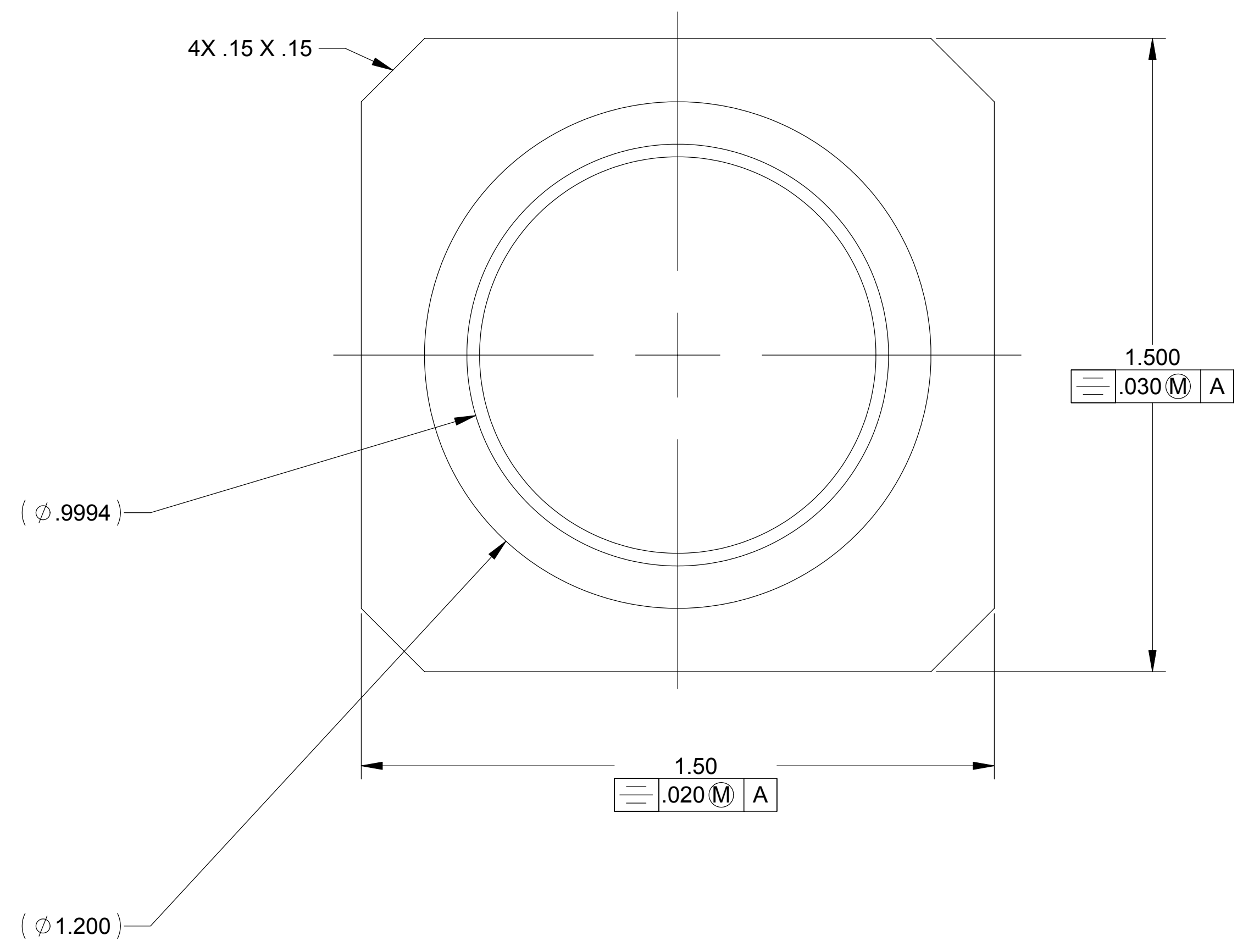
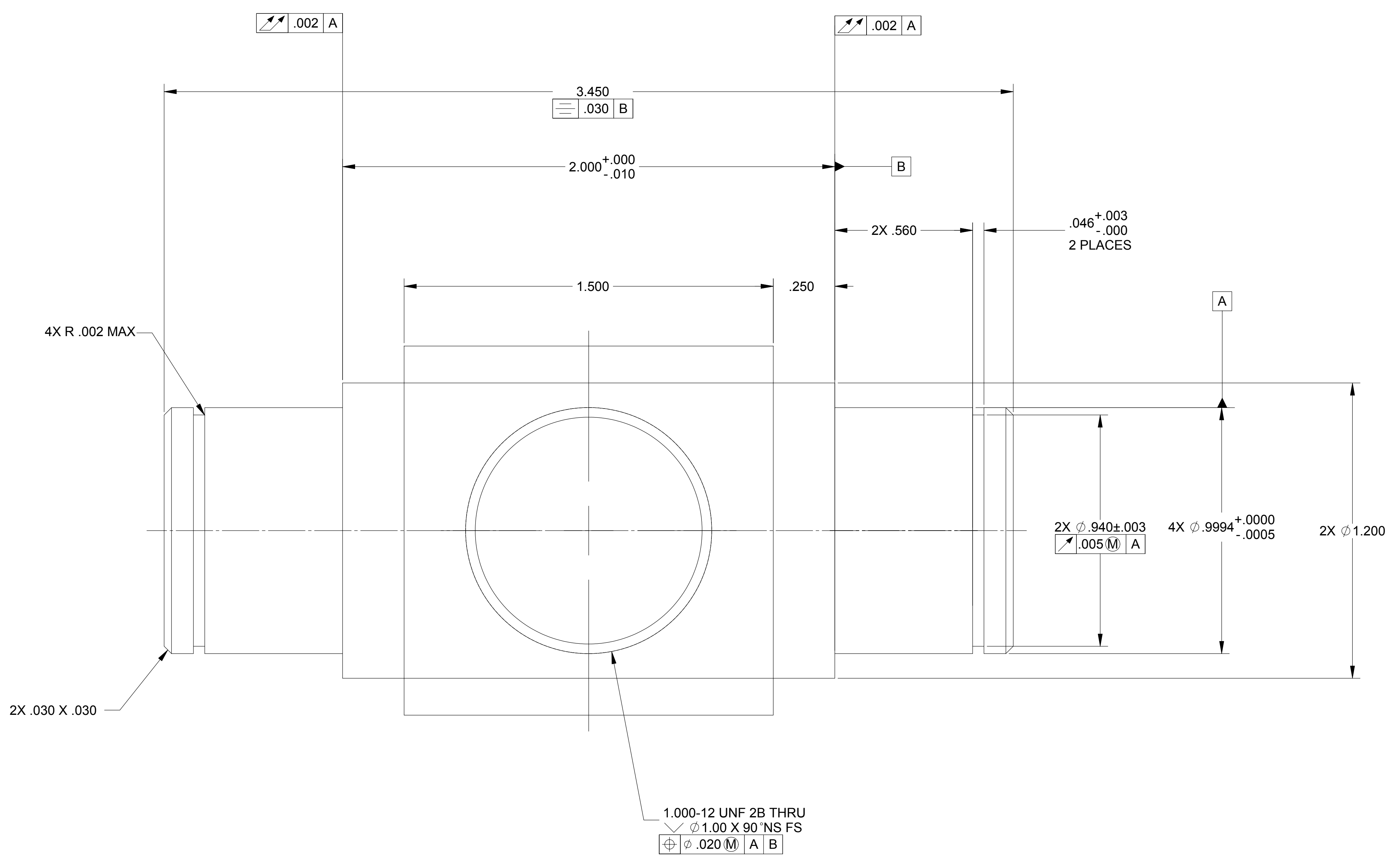

- NOTES: UNLESS OTHERWISE SPECIFIED:
1. REMOVE ALL BURRS AND SHARP EDGES.
 2. MACHINE FILLET RADII .003-.015.

THIS DOCUMENT MAY CONTAIN ITAR CONTROLLED INFORMATION AND/OR COMMERCE CONTROLLED INFORMATION EXPORT RESTRICTIONS MAY APPLY

CONTRACT NO		ITEM NO		REF DES		CAGE NO		PART OR IDENTIFYING NO		NOMENCLATURE OR DESCRIPTION		SPECIFICATION		MATERIAL OR NOTE		ZONE			
20008050		1388								PIVOT, THREADED SPRING TEST FIXTURE LIGO-D048069-A				CRES 4130					
20008069.X_1										UNLESS OTHERWISE SPECIFIED DIMENSIONS ARE IN INCHES TOLERANCES DECIMALS .XX ±.03 ANGLES XXX ±.010 ±12° MACHINE FINISH 63 DO NOT SCALE DRAWING INTERPRET DWG PER ASME Y14.5M - 1994 MATERIAL CRES 4130		PARTS LIST		UNLESS OTHERWISE SPECIFIED DIMENSIONS ARE IN INCHES TOLERANCES DECIMALS .XX ±.03 ANGLES XXX ±.010 ±12° MACHINE FINISH 63 DO NOT SCALE DRAWING INTERPRET DWG PER ASME Y14.5M - 1994 MATERIAL CRES 4130		ALLIANCE SPACESYSTEMS, INC. 1250 Lincoln Ave., Suite 100 Pasadena, CA 91103		REV A	

RELEASED
8/3/2004

asi ALLIANCE SPACESYSTEMS, INC.
1250 Lincoln Ave., Suite 100
Pasadena, CA 91103

PIVOT, THREADED SPRING TEST FIXTURE LIGO-D048069-A

SIZE E CAGE CODE 1KNU9
SCALE 4:1 UNCLASSIFIED SHEET 1 OF 1

8

7

6

5

4

3

2

1

REV 704