

NOTES: (UNLESS OTHERWISE SPECIFIED)

MATERIAL: STAINLESS STEEL 303

SURFACE: NOTE ONE SIDE LAPPED FOR FLATNESS

REV.	DATE	DCN #	DRAWING TREE #
A	4/21/04	E040214-00-D	

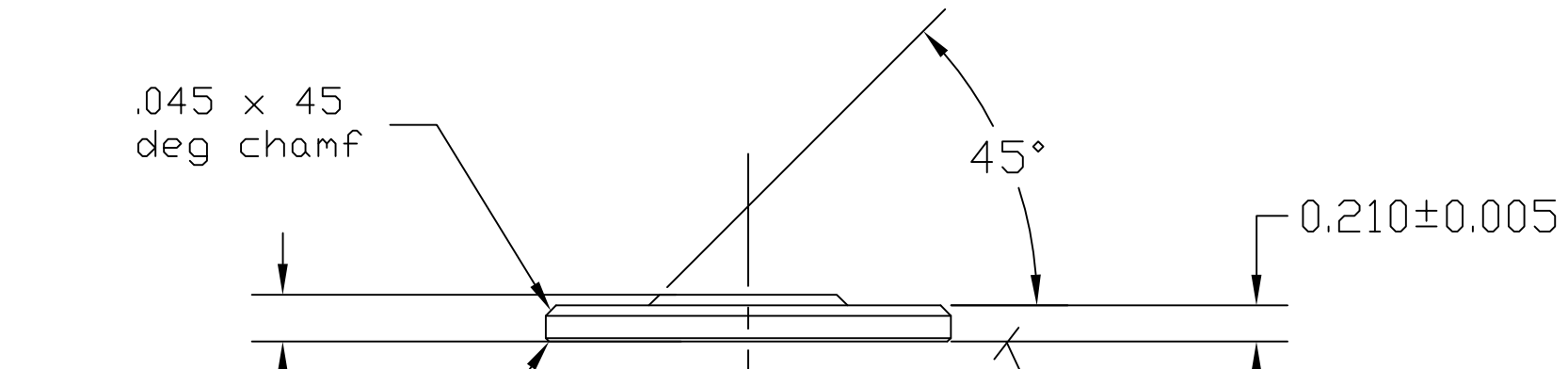
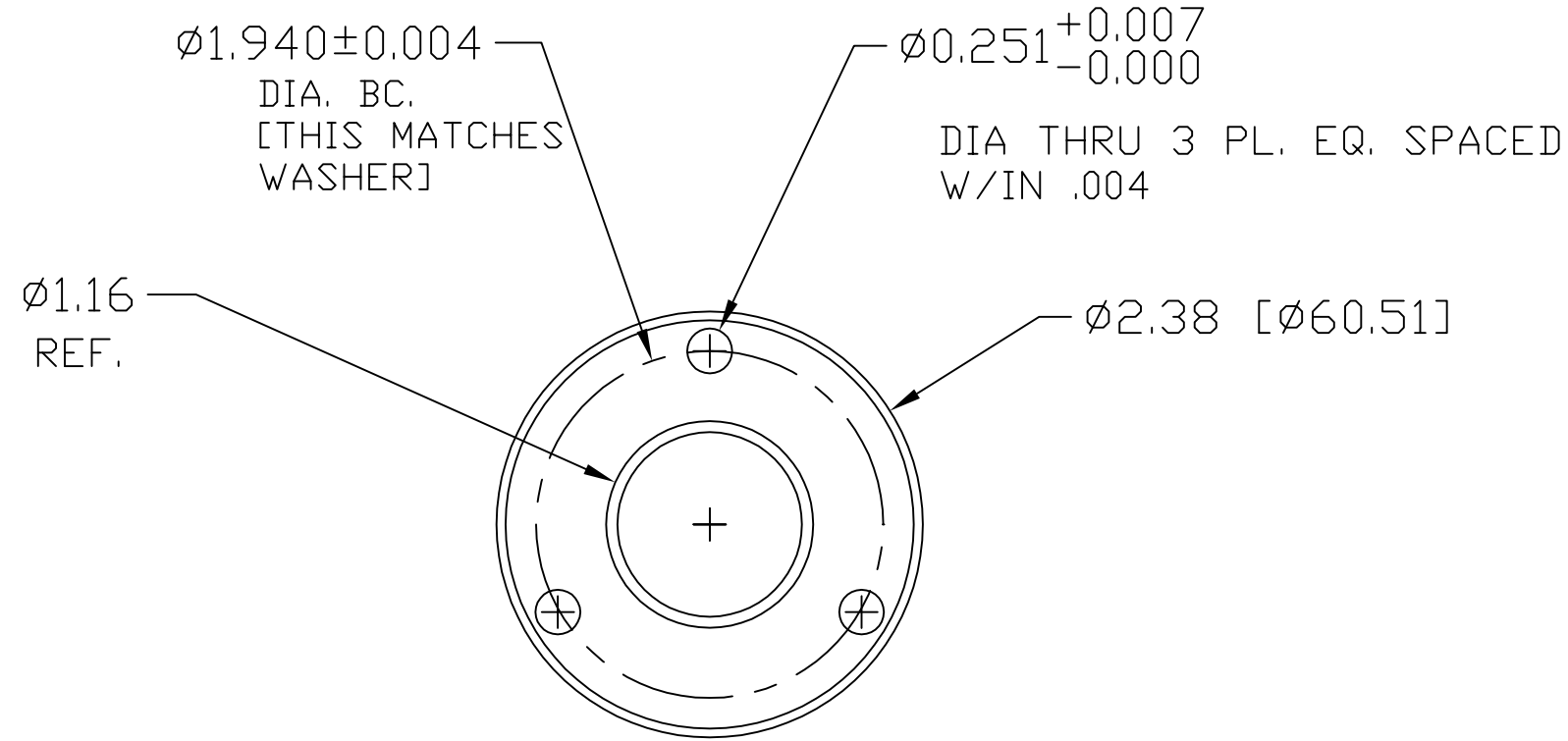

LAP THIS SURFACE FLAT BY HAND OR MACHINE

ITEM NO.	REQ.	SPARE	TOT. QUANTITY	PART NUMBER	DESCRIPTION	SUPPLIER
PARTS LIST						
UNLESS OTHERWISE SPECIFIED: DIMENSIONS ARE IN INCHES				DATE	NAME	LIGO CALIFORNIA INSTITUTE OF TECHNOLOGY MASSACHUSETTS INSTITUTE OF TECHNOLOGY
TOLERANCES: .XX±: .XXX±: ANGULAR:±				DRAWN	4/21/04	KENM
MATERIAL S. STL # 303				CHECKED		SYSTEM LLO
FINISH N/A						SUB-SYSTEM HEPI
						NEXT ASSY D030072-A
				COMMENTS:		PART NAME RESISTOR, CAP
				SIZE	DWG. NO.	REV
				B	D030748-A	A
				SCALE:		SHEET 1 OF 1