

NOTES: (UNLESS OTHERWISE SPECIFIED)

1. DIMENSIONS IN INCHES.
2. BREAK ALL SHARP EDGES.
3. ALL MACHINING FLUIDS SHALL BE WATER SOLUABLE AND FREE OF SULFUR, CHLORINE AND SILICONE, SUCH AS CINCINNATI MILACRON'S CIMTECH 410 (STAINLESS STEEL.)
4. ETCH OR STAMP THE DRAWING PART NUMBER ON NOTED SURFACE OF PART AND THEN A THREE DIGIT SERIAL NUMBER. SERIAL NUMBERS START AT 001 FOR THE FIRST PART AND PROCEED CONSEQUETIVELY. USE .07" HIGH CHARACTERS. EXAMPLE: ~~D010173-A 001~~
D030115-A 001

REV	DATE	DRAWN BY	CHECKED	DCC	DCN/DESCRIPTION
A	9/03	J. Romie			E030462/INITIAL RELEASE

A
B
C
D

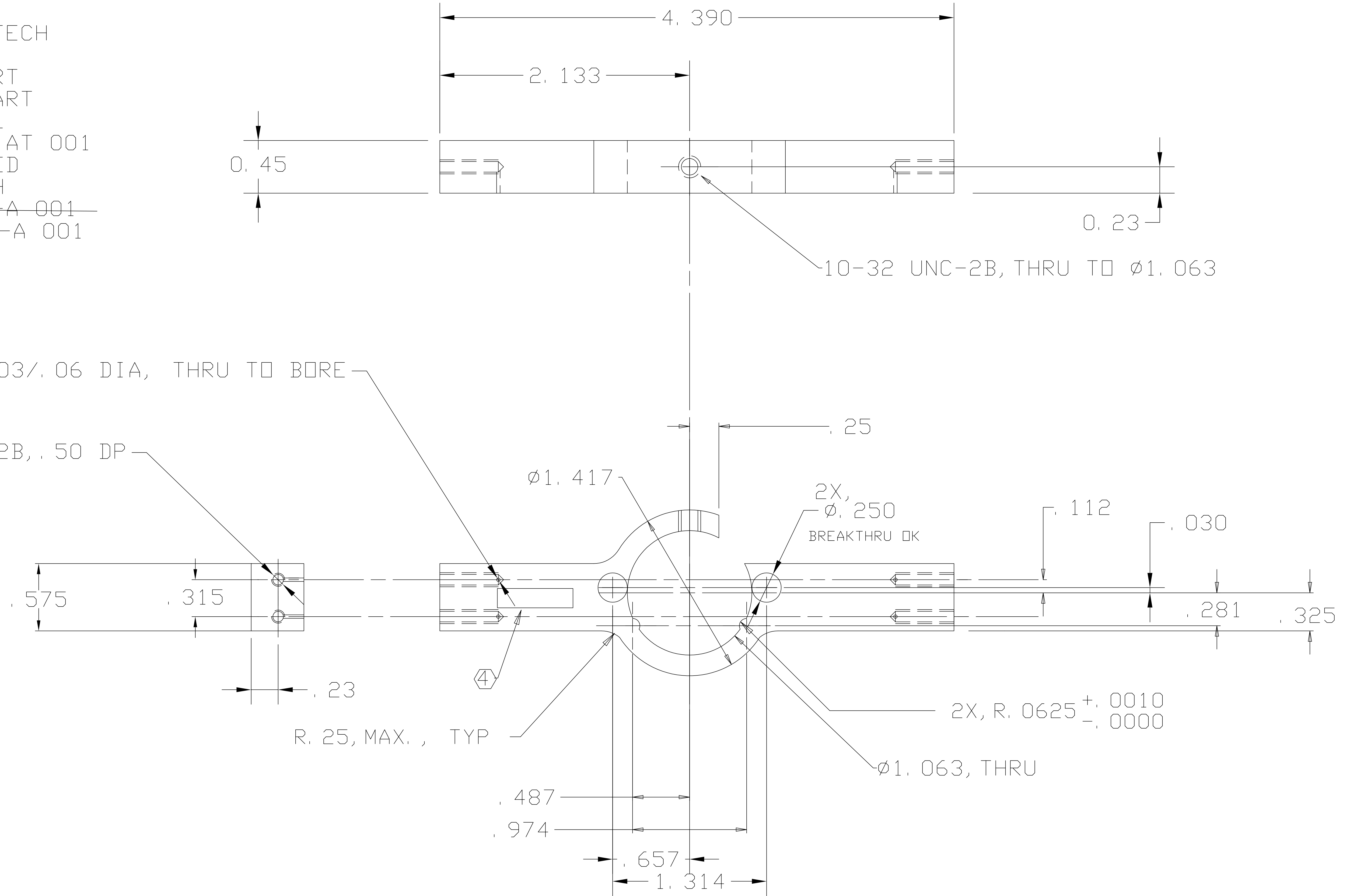

UNLESS OTHERWISE SPECIFIED DIMENSIONS ARE IN INCHES TOLERANCES ARE: FRACTIONS DECIMALS 0. XX=±0.01 0. XXX=±0.005 ANGLES=±0.5° DO NOT SCALE DRAWING	APPROVALS		DATE	LIGO CALIFORNIA INSTITUTE OF TECHNOLOGY MASSACHUSETTS INSTITUTE OF TECHNOLOGY
	DRAWN J. ROMIE	CHECKED	3/03	
NEXT ASSEMBLY D030110	MATERIAL 300 SERIES SST		FINISH	TITLE GIN GIN ETM HEAD HOLDER, SIDE
FILE LOCATION /home/dcc/docs/D030115.pdf				DWG NO. D030115
			SCALE 1/1	REV A
			SHEET 1 OF 1	

1

2

3

4