

NOTES: (UNLESS OTHERWISE SPECIFIED)

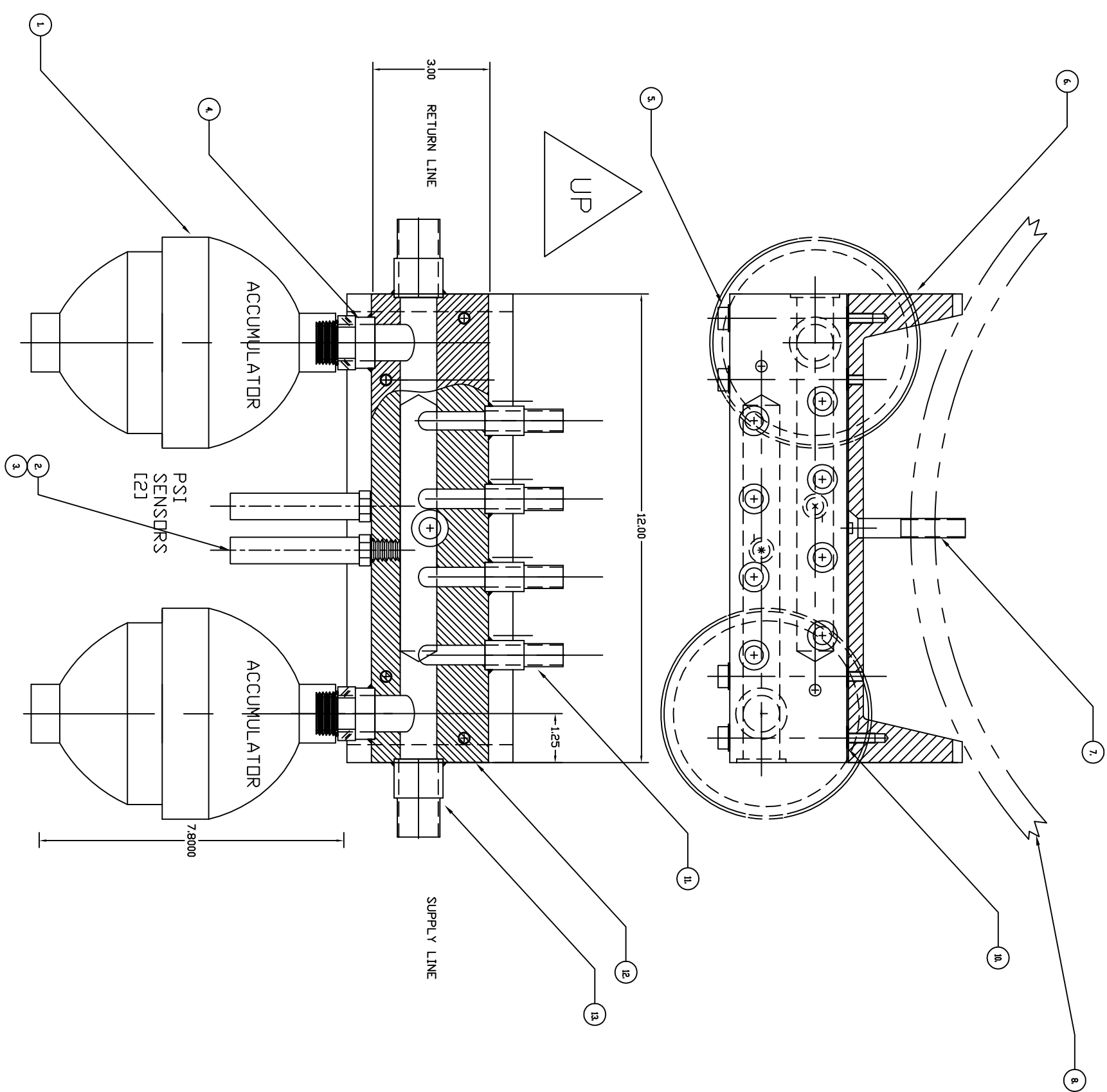

REV	DATE	BY	CHKD
1	2-2-88		
2			
3			

NO.	QTY	DESCRIPTION	SUPPLIER
1		S STL. WASHER	MC MASTER
2			
3			
4			
5			
6			
7			
8			
9			
10			
11			
12			
13			
14			
15			
16			
17			
18			
19			

PARTS LIST	
NO.	DESCRIPTION
1	S STL. WASHER
2	
3	
4	
5	
6	
7	
8	
9	
10	
11	
12	
13	
14	
15	
16	
17	
18	
19	

MASSACHUSETTS INSTITUTE OF TECHNOLOGY
 DEPARTMENT OF MECHANICAL ENGINEERING
 PROJECT: 4 MAIN MOUNTED
 DRAWING NO: D030074-A
 SCALE: NONE
 SHEET 1 OF 1