

1

2

3

4

NOTES: (UNLESS OTHERWISE SPECIFIED)

- 1. DIMENSIONS IN INCHES.
- 2. BREAK ALL SHARP EDGES.

REV	DATE	DRAWN BY	CHECKED	DCC	DCN/DESCRIPTION
A	9/03	J. ROMIE			E030462/INITIAL RELEASE

A

A

B

B

C

C

D

D

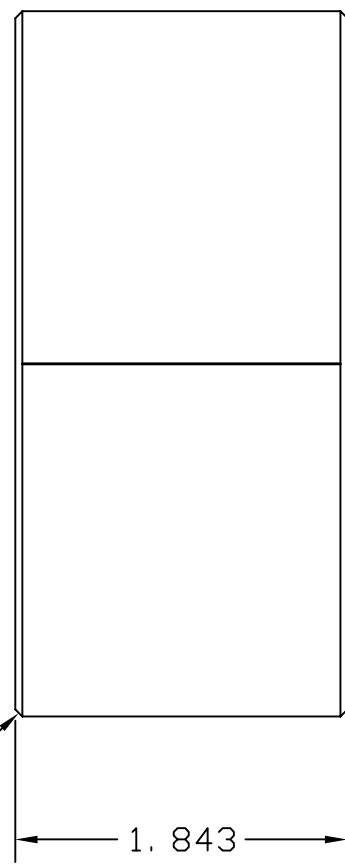
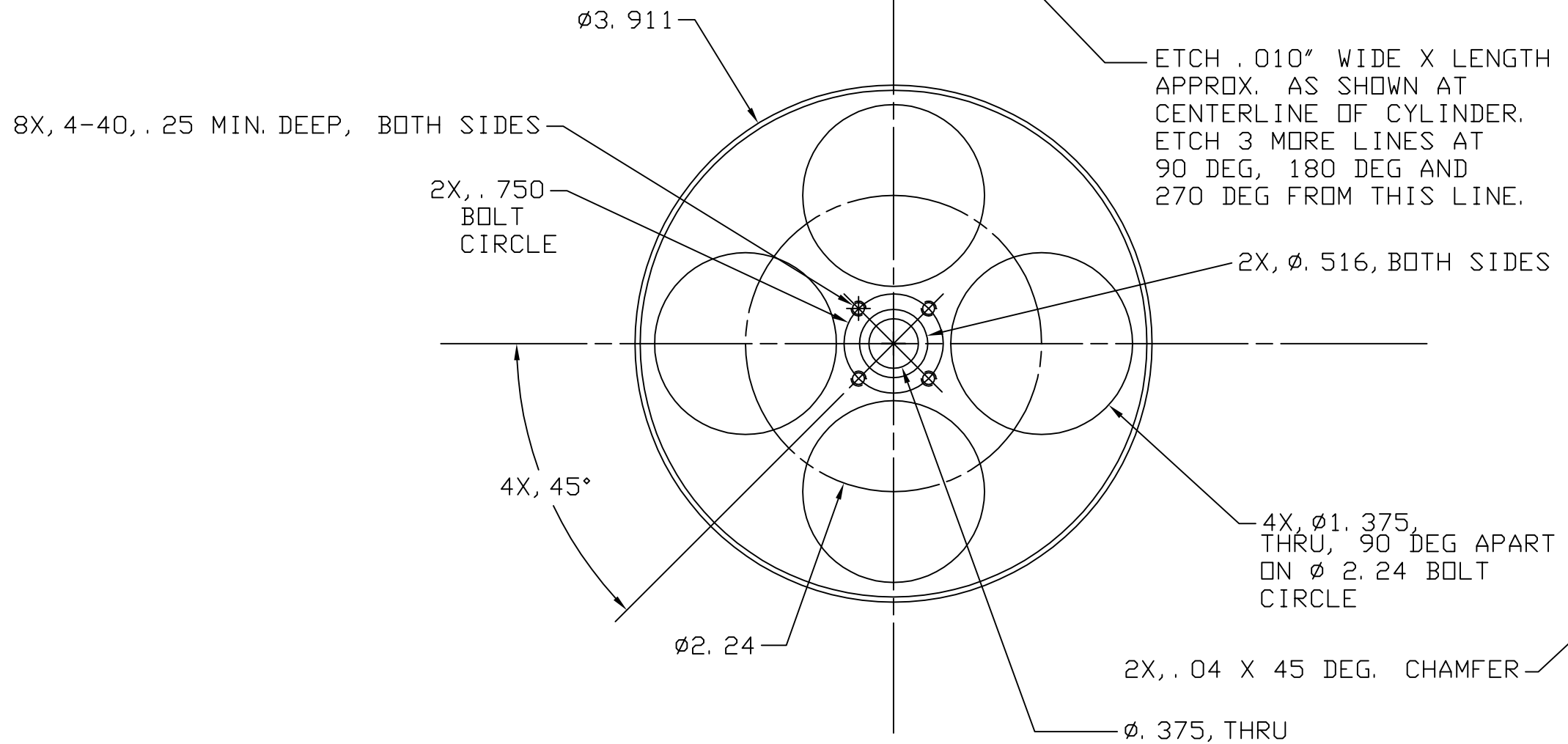
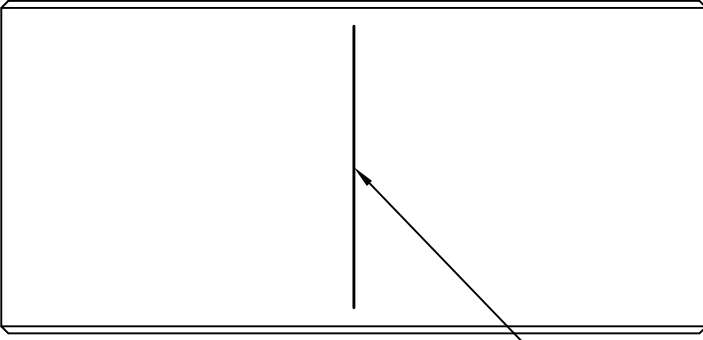

UNLESS OTHERWISE SPECIFIED DIMENSIONS ARE IN INCHES TOLERANCES ARE: FRACTIONS DECIMALS 0. XX=±0. 01 0. XXX=±0. 005 ANGLES=±0. 5° DO NOT SCALE DRAWING	APPROVALS	DATE	LIGO CALIFORNIA INSTITUTE OF TECHNOLOGY MASSACHUSETTS INSTITUTE OF TECHNOLOGY
	DRAWN J. ROMIE	11/02	
NEXT ASSEMBLY D020662	CHECKED		TITLE GIN GIN ITM DUMMY OPTIC
FILE LOCATION /home/dcc/docs/D020693.pdf	MATERIAL 300 SERIES STAINLESS	FINISH	DWG NO. D020693
			SCALE 1/1
			SHEET 1 OF 1

1

2

3

4

REV
A