



*LIGO Laboratory / LIGO Scientific Collaboration*

E1000380-V2

*LIGO*

2 Sept. 2010

---

**Stage 1-2 Horizontal Actuator Assembly Procedure**

---

S.Biscans, M.Hillard

Distribution of this document:  
Advanced LIGO Project

This is an internal working note  
of the LIGO Laboratory.

**California Institute of Technology**  
**LIGO Project – MS 18-34**  
**1200 E. California Blvd.**  
**Pasadena, CA 91125**  
Phone (626) 395-2129  
Fax (626) 304-9834  
E-mail: [info@ligo.caltech.edu](mailto:info@ligo.caltech.edu)

**Massachusetts Institute of Technology**  
**LIGO Project – NW22-295**  
**185 Albany St**  
**Cambridge, MA 02139**  
Phone (617) 253-4824  
Fax (617) 253-7014  
E-mail: [info@ligo.mit.edu](mailto:info@ligo.mit.edu)

**LIGO Hanford Observatory**  
**P.O. Box 1970**  
**Mail Stop S9-02**  
**Richland WA 99352**  
Phone 509-372-8106  
Fax 509-372-8137

**LIGO Livingston Observatory**  
**P.O. Box 940**  
**Livingston, LA 70754**  
Phone 225-686-3100  
Fax 225-686-7189

ITEM NO.	PART NUMBER	DESCRIPTION	MATERIAL	REQ
22	D1001737	Step Pin, Small Actuator, alIGO BSC ISI	18-8 SSTL	2
21	McMaster_90145A539	Dowel Pin 1/4" (.2501) x 5/8" L, 18.8 SST	18-8 Stainless	2
20	McMASTER_92176A106	Screw 4-40 x .25" lg, SHCS	18-8 SSTL	4
19	McMASTER_92176A113	SCREW, SHCS 4-40 X .75 LG.	18-8 SSTL	8
18	UCC_WFY-04	Flat Washer, #4, .115 ID X .209 OD X .016 THK	18-8 SSTL	8
17	UC_COMPONENTS_WFY-08	Washer Ventiled, .17 ID X .304 OD X .032 THK #8	18-8 SS	4
16	UCC_C-808-NA	SHCS, 8-32 X .50 LG, AG PLATED	18-8 SS	4
15	HOLKROME_78100	SHCS, 3/8"-1.6x1.25"	18-8 SS	5
14	UC_COMPONENTS_WFY-38	Washer Ventiled, .39 ID X .43 OD X .032 THK #3/8"	18-8 SS	3
13	MC MASTER 92217A520	3/8" Washer, 47/64" OD, 13/32" ID, 0.05" to 0.12" THCK	304, 316, OR 302 SSTL	3
12	McMASTER_92240A722	SCREW HEX HEAD, 1/2-13 X 2.5 FULL THD	18-8 SSTL	1
11	UC_COMPONENTS_WFY-50	Ventiled Washer, .515 ID X .87 OD X .032 THK #1/2"	18-8 SS	1
10	D0902154	SMALL ACTUATOR THERMAL BAR LEFT, alIGO BSC ISI	COPPER	1
9	D0902153	SMALL ACTUATOR THERMAL BAR RIGHT, alIGO BSC ISI	COPPER	1
8	D0902134	MAGNET TO STAGE2 INTERPOSER, alIGO BSC ISI	604-116 Al	1
7	D0902155	SMALL ACTUATOR BOBBIN COIL BRACKET, alIGO BSC ISI	604-116 Al	1
6	D1000678	SPHERICAL WASHER, 2 IN. OD CONVEX, alIGO BSC	304 SSTL	1
5	D0902156	SPHERICAL WASHER, 1 IN. OD CONCAVE, alIGO BSC ISI	304 SSTL	1
4	D0902157	SPHERICAL WASHER, 1 IN. OD CONCAVE, alIGO BSC ISI	304 SSTL	1
3	D1000679	SPHERICAL WASHER, 1 IN. OD CONVEX, alIGO BSC ISI	304 SSTL	1
2	D0902162	SMALL HORIZONTAL ACTUATOR SLIDE BRACKET, alIGO BSC ISI	604-116 Al	1
1	D1000584	SMALL ACTUATOR, alIGO BSC-ISI	N/A	1

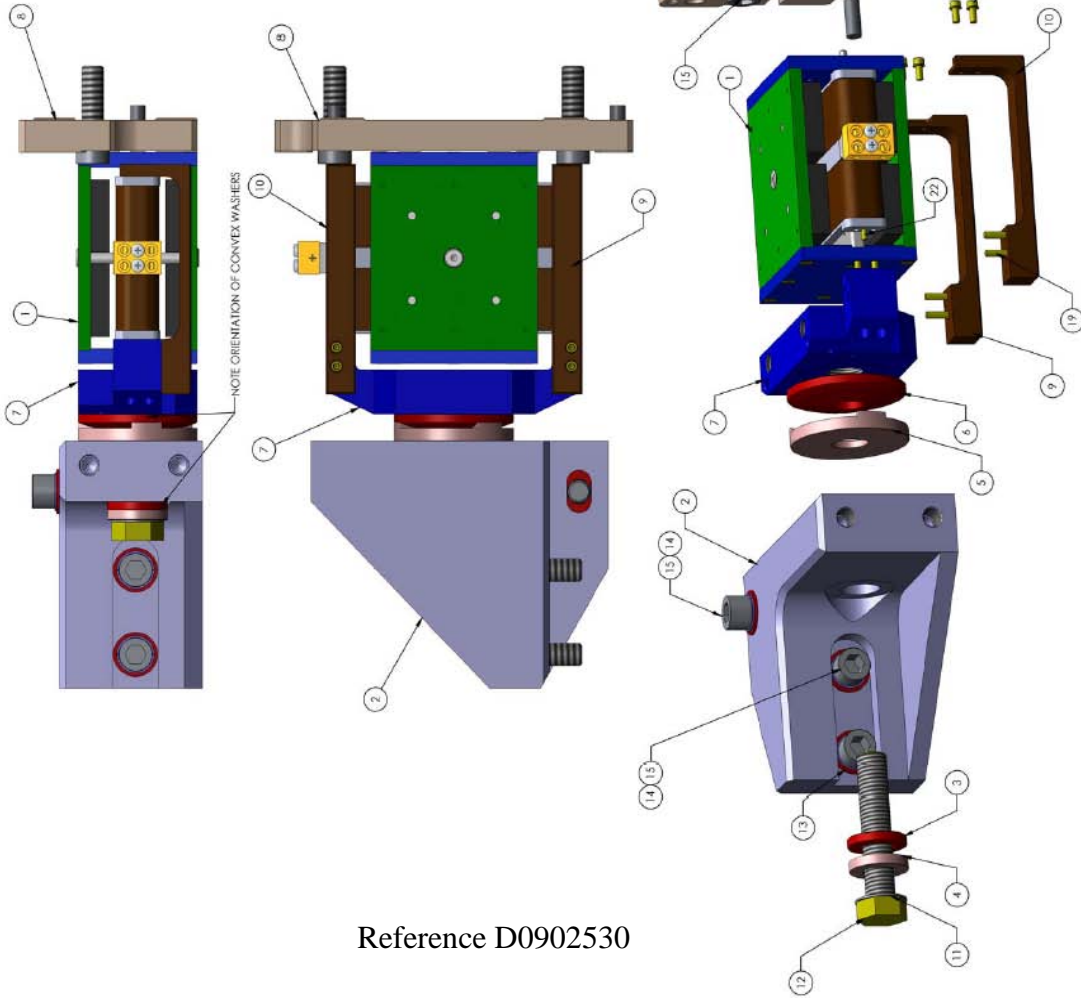

Reference D0902530

**Note : ! Make sure there is no trash in the coil !**  
Remove the two shoulder screws and watch carefully inside the coil.

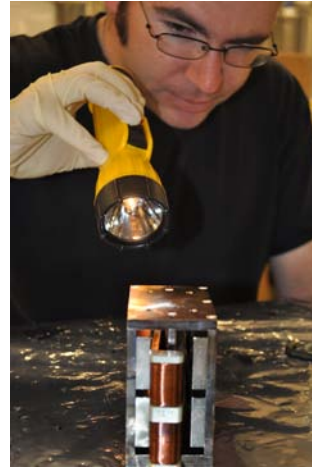
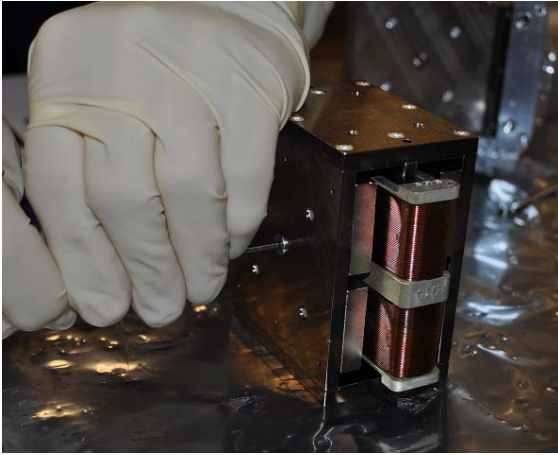

### Clean room standards

For a clean assembly all LIGO standards should be followed, as presented in the latest version of the **LIGO Contamination Control Plan (E0900047)**. Clean room garb including UHV gloves should be worn when working with parts.

All tools that come in contact with assembly should be cleaned to class B standards.

Assembly will be done under a portable clean room. Any time a part of the assembly is not covered by the portable clean room or not being actively worked on it should be covered with appropriate clean covers. (C3 polyester or equivalent).

### Parts prep work: alignment pins and helicoils

To facilitate assembly, parts requiring helicoils and/or pins to be inserted before assembly will be listed to allow preliminary preparation of the parts, after cleaning and before starting general assembly. Preparation need to be complete on the following.

Helicoil:

1. D0902134

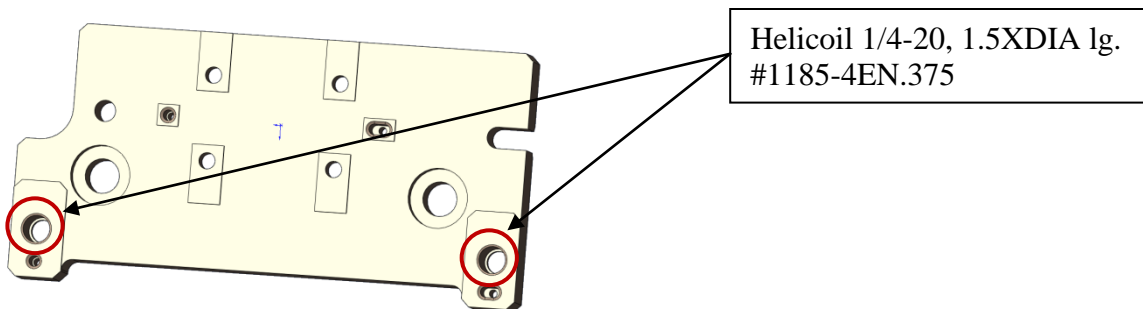

2. D0902162

Helicoil 1/4-20, 1.5XDIA lg.  
#1185-4EN.375

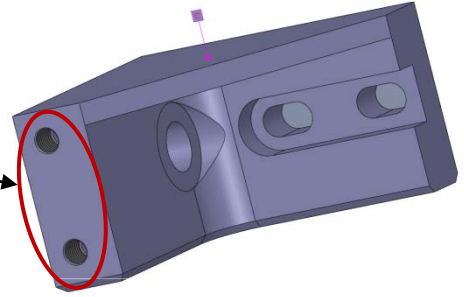

3. D0902155

Helicoil 1/2-23, 1XDIA lg.  
#1185-8EN.500

Helicoil 1/4-20, 1.5XDIA lg.  
#1185-4EN.375

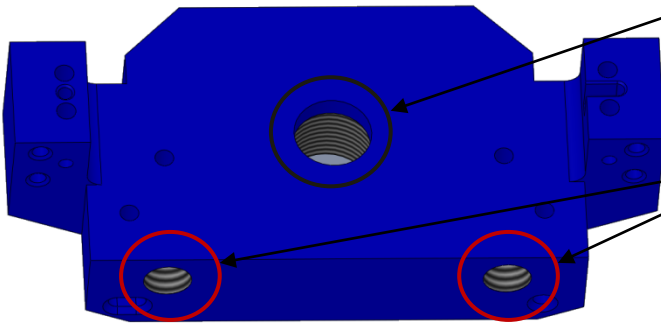

4. D0902136

Helicoil 8-32, 2XDIA lg.  
#1185-2EN.328

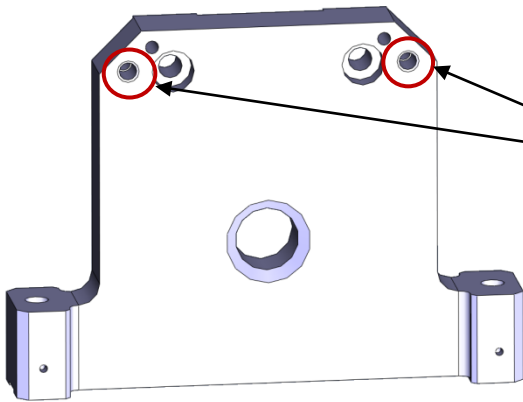

Dowel Pins:

1. D0902136

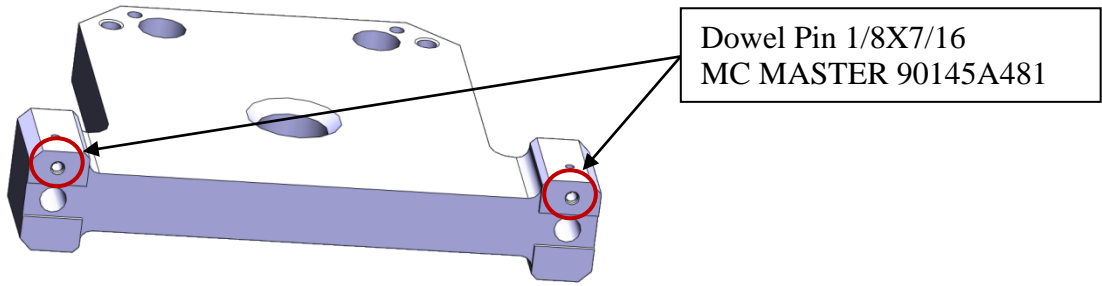

2. D0902435

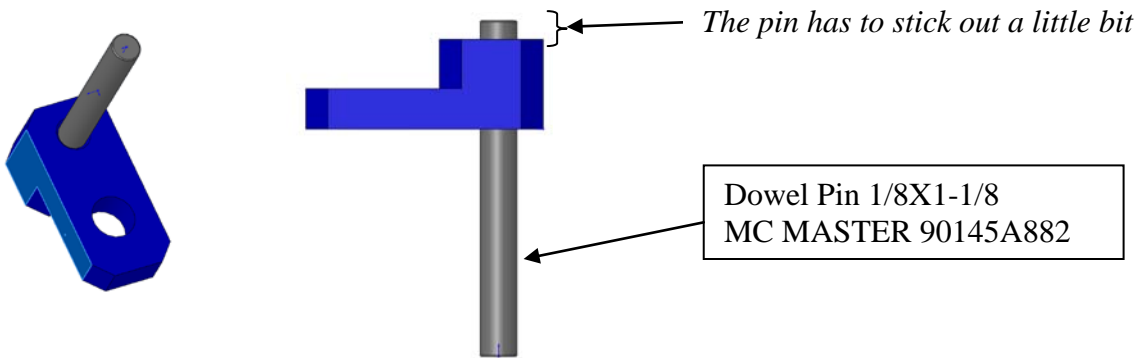

**Assembly procedure**

1. Insert Item (23) (D1001737) Step Pin into Item (1) (D1000584) Small Actuator.

*Note : Non pined face*

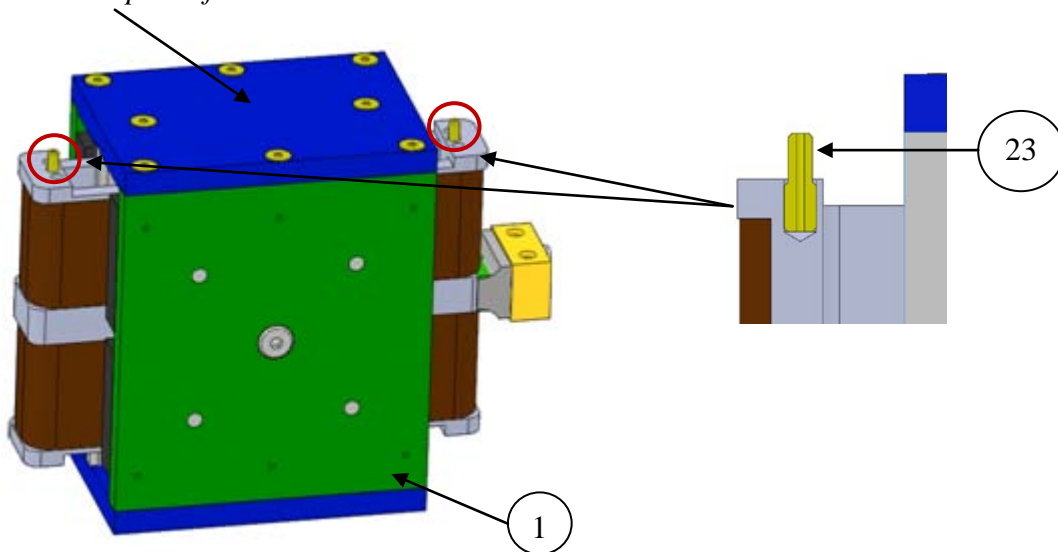

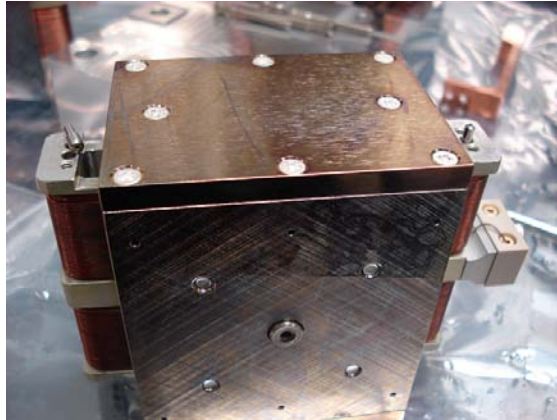

2. Attach Item (5) (D0902155) Actuator Coil Bracket, to Item (23) (D1001737) Step Pin and Item (1) (D1000584) Small Actuator using Item (13) washer and Item (14) screw.

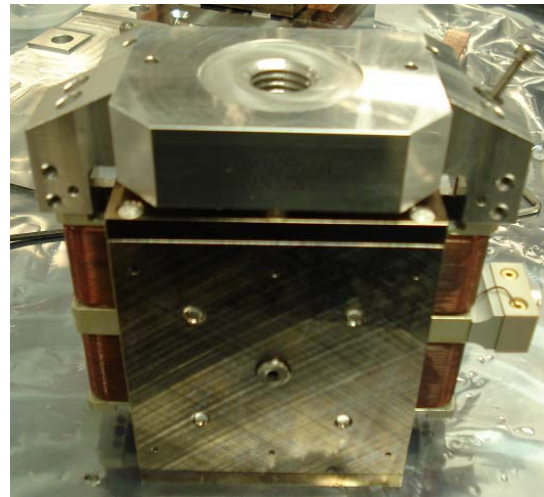
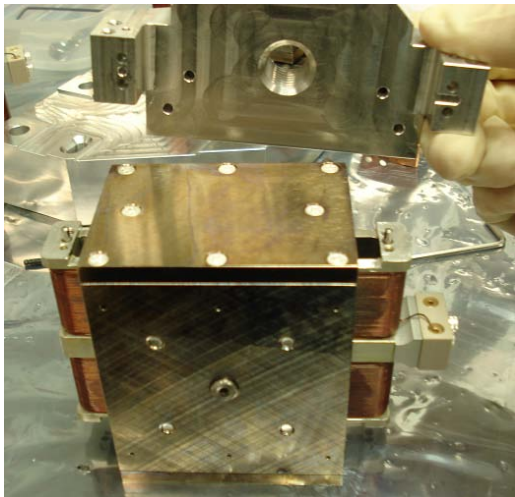
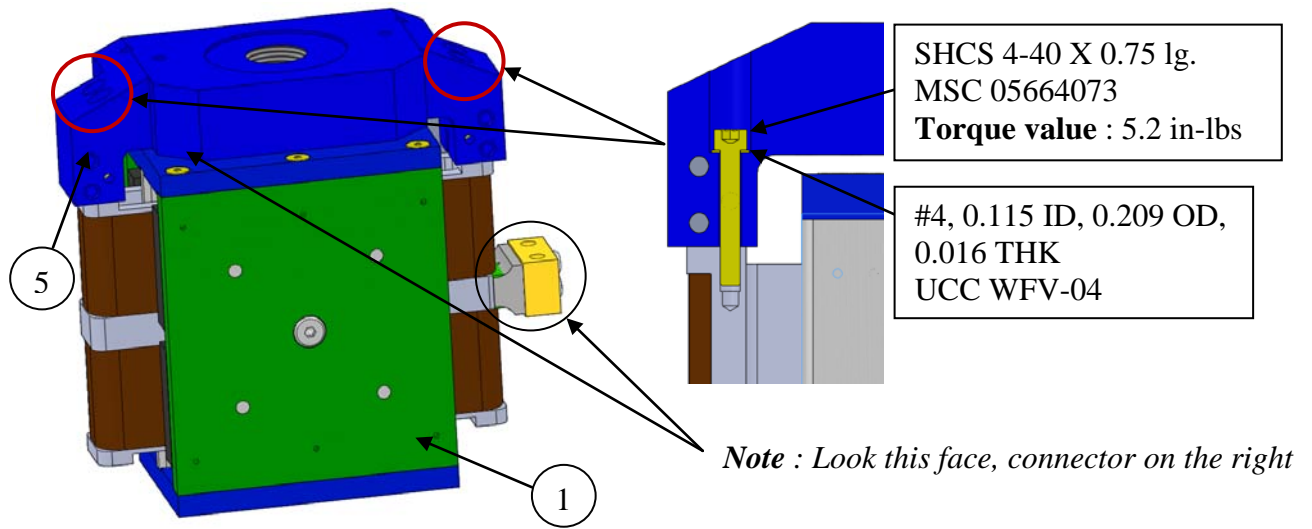



3. Attach Items (3) (D0902154) Left Thermal Bar and Item (4) (D0902153) Right Thermal Bar, to Item (1) (D1000584) Small Actuator and Item (5) (D0902155) Actuator Coil Bracket using Item (13) washer and Items (14)/(15) screws.

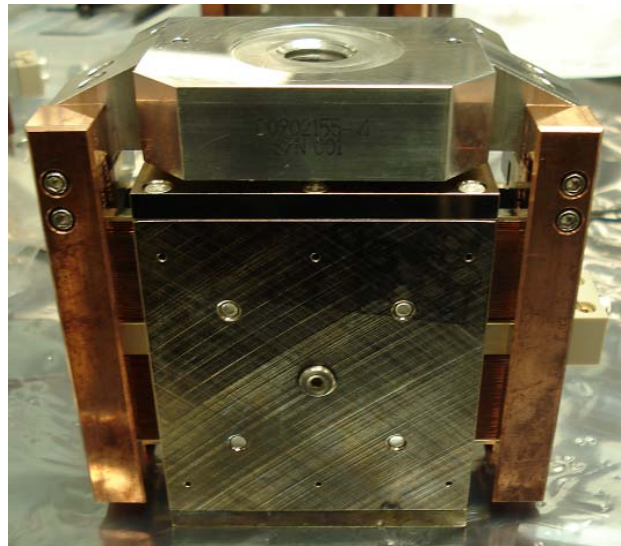
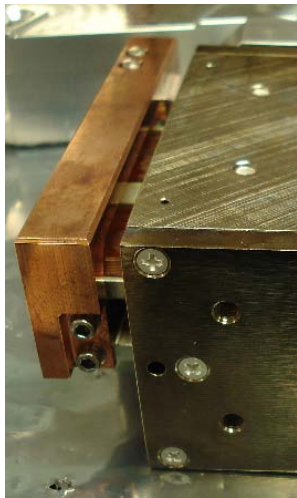
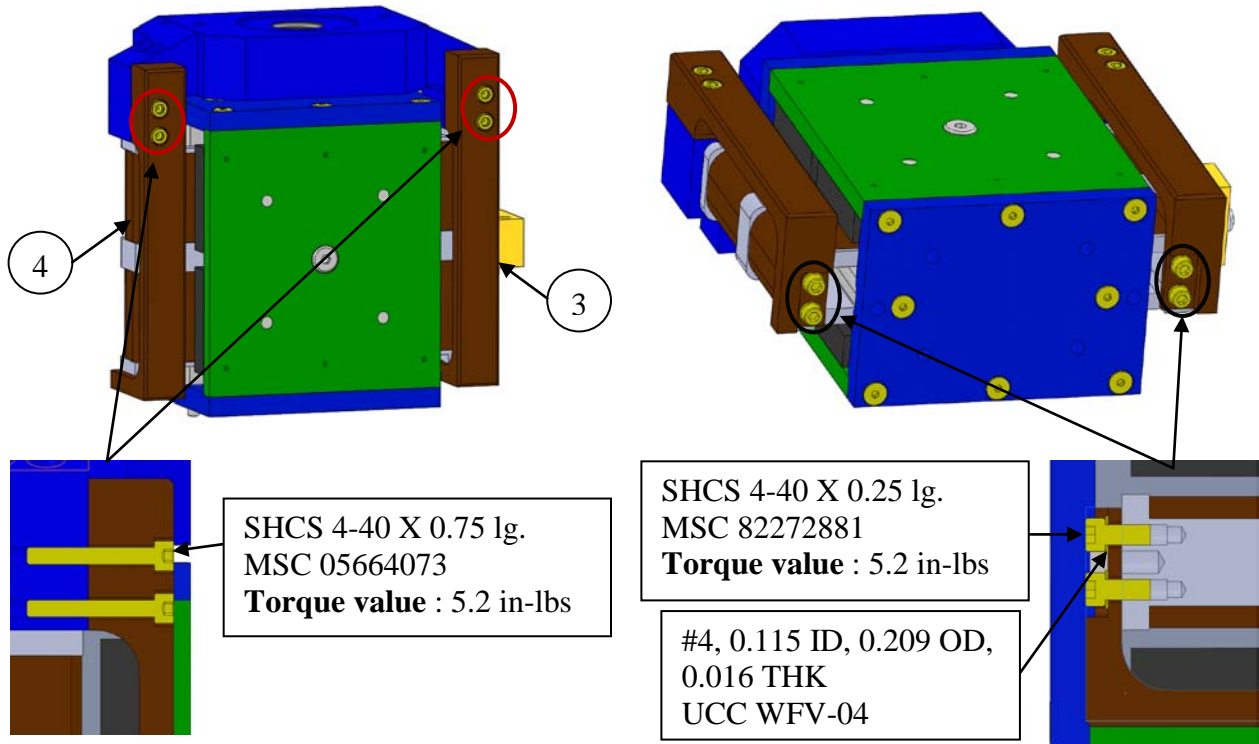

4. Insert Item Dowel Pin into Item (1) (D0902749) Large Actuator.

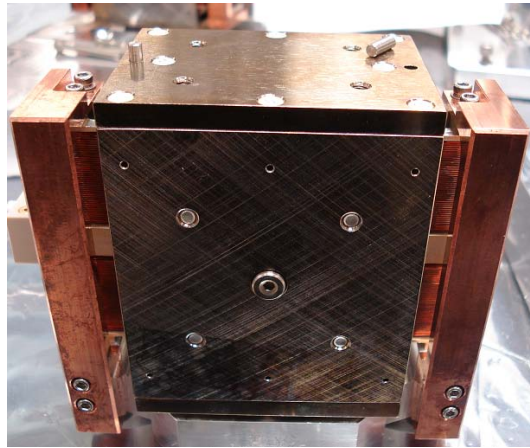
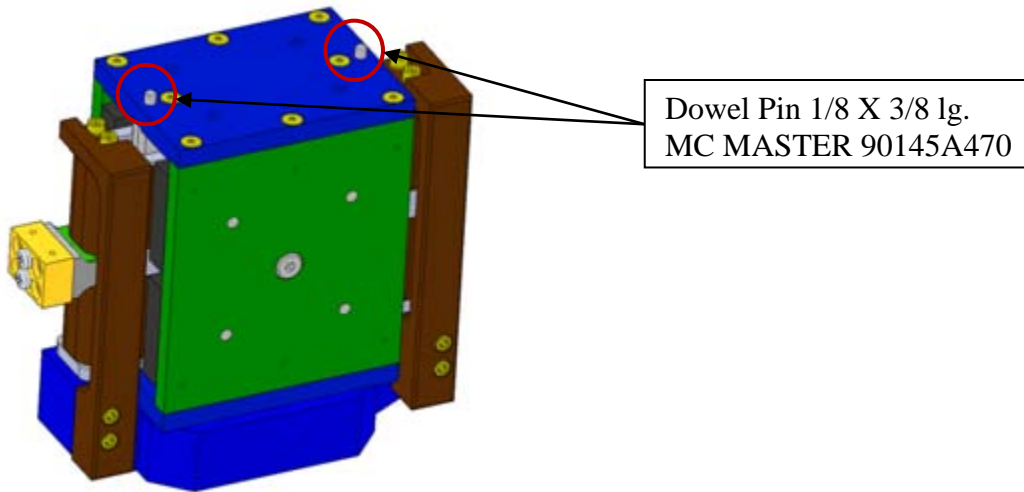

5. Attach Items (8) (D0902134) Small Actuator Interposer, to Item (1) (D1000584) Small Actuator using Item (16) vent washer and Items (15) screw.



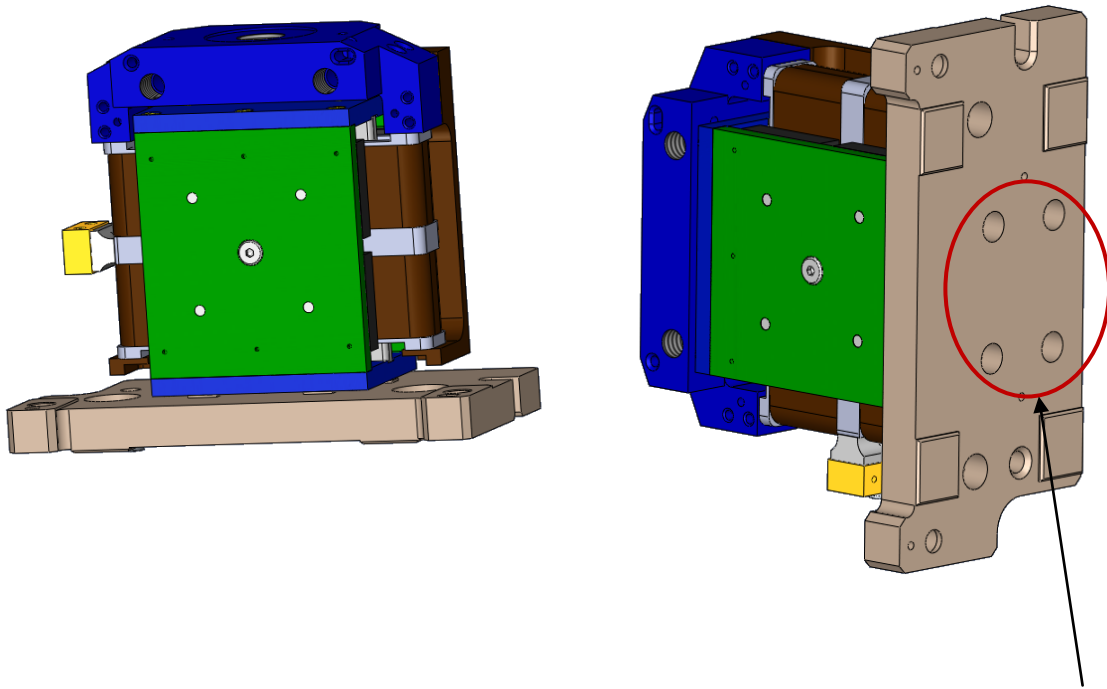

SHCS 8-32, 0.50 lg. AG Plate  
 UCC C-808-NA  
**Torque value : 19.8 in-lbs**

0.17 ID, 0.304 OD, 0.032 THK  
 UC COMPONENTS WFV 08

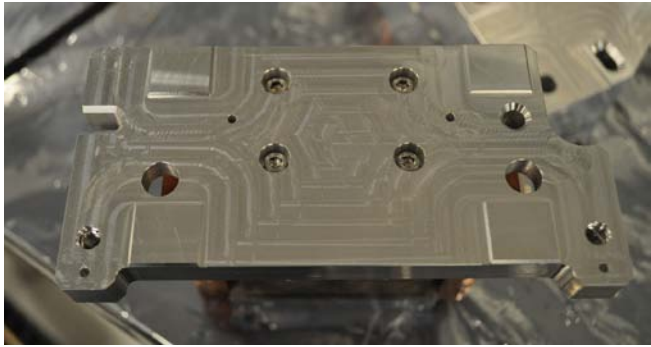
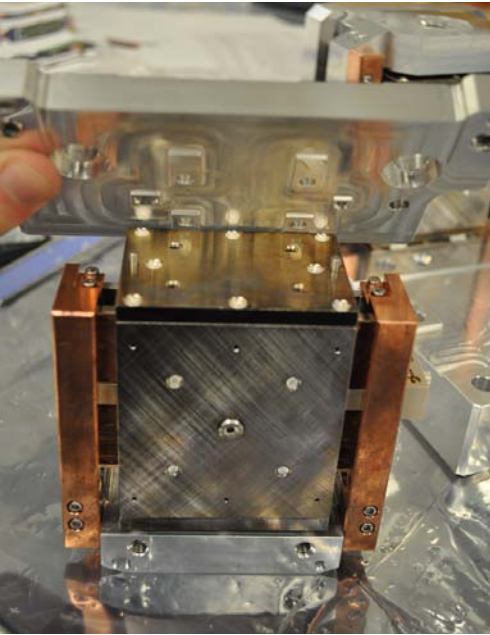

**6. Tooling Bracket Assembly**

Attach Part **only the bottom** of D0902136 Tooling Bracket, to Item (8) (D0902134) Small Actuator Interposer using vent washer and screw (5)/(6), as shown on Figure below.

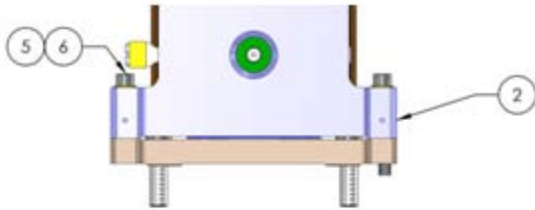

7	McMASTER_90145A481	DOWEL PIN .125 DIA X .43 LG.	18-8 SSSL	2
6	HOLOKROME_78066	SHCS	18-8 SS	2
5	UC_COMPONENTS_WFV-25	Vented Washer, .255 ID X .468 OD X .032 THK #1/4	18-8 SSSL	2
4	HOLOKROME_78060	SHCS, 1/4"-20x.875"	18-8 SS	2
3	D0902434	Pin Key, Small Actuator Tooling Bar	N/A	2
2	D0902136	MAGNET ASSEMBLY TO BOBBIN TOOLING BRACKET, aLIGO BSC ISI	6061-T6 Al	1
1	D0902530	Stage 1-2, Horizontal Actuator Assm	N/A	1
ITEM NO.	PART NUMBER	DESCRIPTION	MATERIAL	REQ
PARTS LIST				



**7. Loose** the 2 shoulder screws of Item (1) (D1000584) Small Actuator.

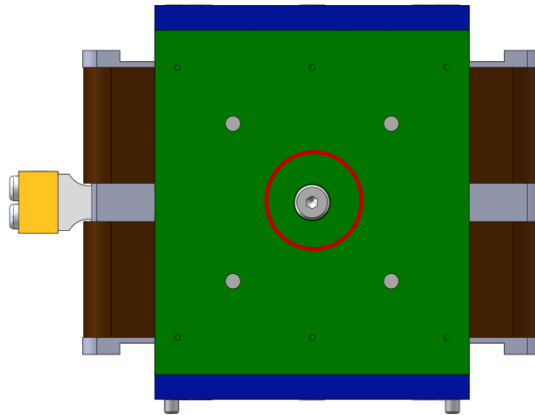

**8. Slide** Pin Carrier (D0902434) into the Tooling Bar and Item (7) (D0902155).

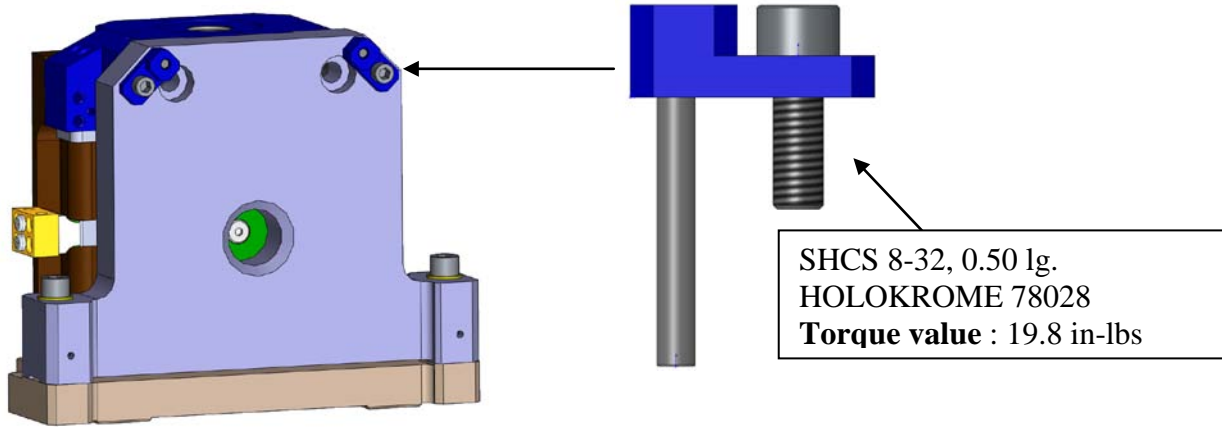

9. **Remove** the 2 shoulder screws of Item (1) (D1000584) Small Actuator.

10. Add the two last screws and washers in the Tooling Bar

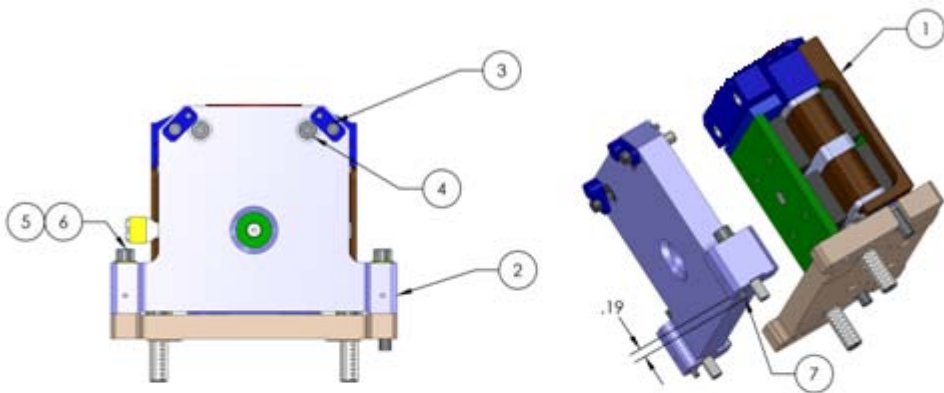

7	McMASTER_90145A481	DOWEL PIN .125 DIA X .43 LG.	18-8 SSSL	2
6	HOLOKROME_78066	SHCS	18-8 SS	2
5	UC_COMPONENTS_WFV-25	Vented Washer, .255 ID X .468 OD X .032 THK #1/4	18-8 SSSL	2
4	HOLOKROME_78060	SHCS, 1/4"-20x.875"	18-8 SS	2
3	D0902434	Pin Key, Small Actuator Tooling Bar	N/A	2
2	D0902136	MAGNET ASSEMBLY TO BOBBIN TOOLING BRACKET, ALIGO BSC ISI	6061-T6 Al	1
1	D0902530	Stage 1-2, Horizontal Actuator Assm	N/A	1
ITEM NO.	PART NUMBER	DESCRIPTION	MATERIAL	REQ
PARTS LIST				

11. Remove the Pin Carrier (D0902434).

## Gap Test : Go / No Go

- Check the gap between the coil and the magnet with shims on both sides.  
Go : 0.085 inches  
No Go : 0.115 inches

